

Filtro para aceite
Filtre a huile
Oil filter
Ölfilter
Filtro dell'olio

GAMA 700-900

Modelos:

FF-35

March 2004 Marzo



Fagor Industrial

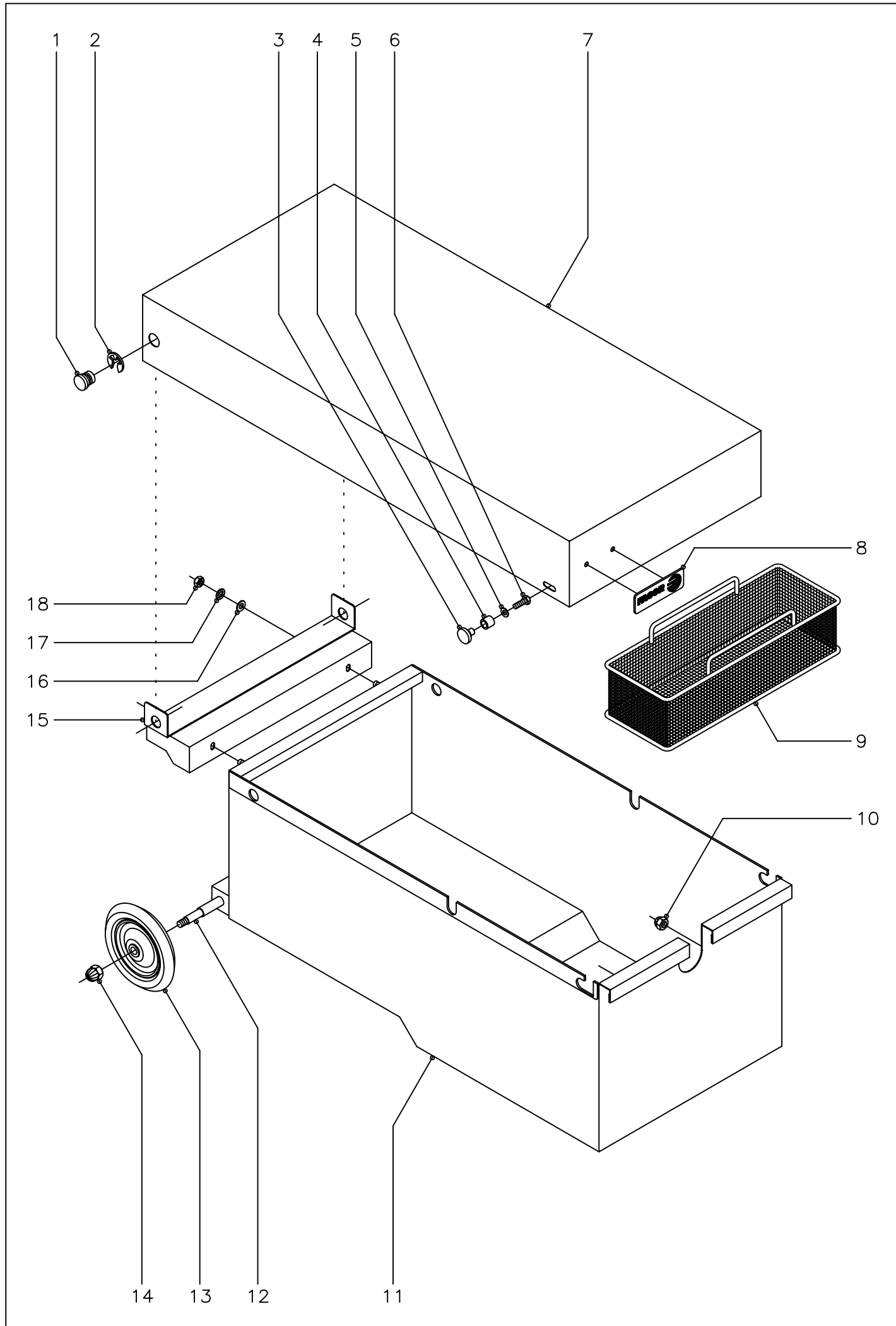

N plano C-1524	Firma 	Fecha 3-2004	Aparato DEPOSITO FILTRO PARA ACEITE FPA-35	Lamina 1	Fagor Industrial S.Coop. FAGOR  Oñate
-------------------	--	-----------------	--	-------------	--

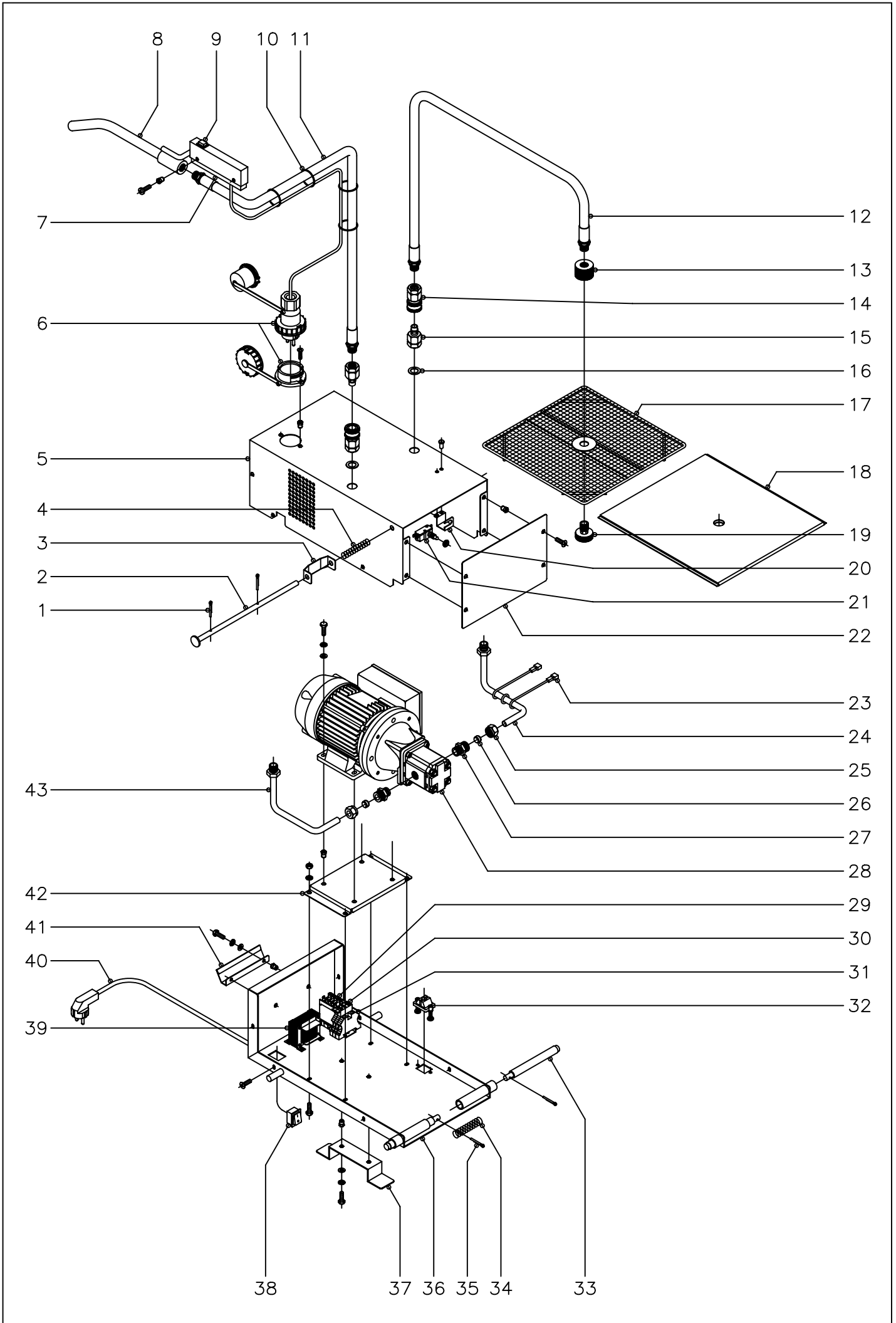

N plano C-1525	Firma 	Fecha 3-2004	Aparato PARTE FUNCIONAL FILTRO PARA ACEITE FPA-35	Lamina 2	Fagor Industrial S.Coop. FAGOR  Oñate
-------------------	--	-----------------	---	-------------	--

MOD.		FILTRO PARA ACEITE		ZONA	PARTE FUNCIONAL							PLANO	C-1525
ITEM	CODIGO	DENOMINACION	TEXTO	FPA-35									NOTAS
1	Q352024	Pasador de aletas Ø4x25	Colter pin Ø 4x25	2									
2	H032606	Eje interruptor	Switch axle	1									
3	H032604	Pulsador interruptor	Switch button	1									
4	R725007	Resorte	Spring	1									
5	H032802	Anterior de caja	Box frontal	1									
6	H033012	Conector estanco	Connector	1									
	Q042031	Tornillo avellanado M-5x10	Screw M-5x10	2									
	Q221342	Remache exagonal M-5	Rivet M-5	2									
7	H032817	Inferior de caja	Box lower	1									
	Q221341	Remache exagonal M-4	Rivet M-4	4									
	Q032021	Tornillo alomado M-4x10	Screw M-4x10	4									
8	H035007	Tubo desagüe completo	Complete drain pipe	1									
9	R663032	Pulsador	Button	1									
10	Q307041	Junta torica Ø25,4xØ20,2x2,6	O-ring seal	4									
11	H035009	Manguera desagüe L=1600	Drain hose L=1600	1									
12	H035008	Manguera filtro L=570	Filter hose L=570	1									
13	H035000	Tuerca sujecion filtro	Nut	1									
14	H035014	Enchufe rapido hembra	Fast plug +	2									
15	H035004	Enchufe rapido macho	Fast plug -	2									
16	Q306039	Arandela junta Ø25xØ16,5x1,5	Washer	2									
17	H036501	Filtro metalico	Metal filter	1									
18	H036502	Filtro	Filter	1									
19	H035001	Tornillo sujecion filtro	Filter hold screw	1									
20	X363020	Soporte microrruptor	Microswitch support	1									
	Q419005	Remache tubular Ø4x8	Rivet Ø 4x8	2									
21	X343015	Microrruptor	Microswitch	1									
	Q222005	Tuerca exagonal M-10x0,75	Nut M-10x0,75	1									
22	H032813	Base caja	Box base	1									
	Q221342	Remache exagonal M-5	Rivet M-5	4									

MOD.		FILTRO PARA ACEITE		ZONA	PARTE FUNCIONAL							PLANO	C-1525
ITEM	CODIGO	DENOMINACION	TEXTO	FPA-35								NOTAS	
	Q032031	Tornillo alomado M-5x10	Screw M-5x10	4									
23	H033010	Resistencia de calentamiento	Heating element	1									
24	H035012	Tubo filtro derecho (aspiracion)	Right filter pipe	1									
25	Q221336	Tuerca M-18x1,5 (p/tubo Ø 12)	Nut M-18x1,5	2									
26	U055043	Bicono Ø12	Bicone Ø 12	2									
27	H035013	Manguito doble (M-18x1,5 - 1/2")	Double coupling	2									
28	H033014	Motobomba 220 V., 50Hz.	Pump 220 V., 50Hz	1									
	Q221342	Remache exagonal M-5	Rivet M-5	4									
	Q232030	Arandela plana A-5	Washer A-5	4									
	Q242030	Arandela abanico A-5	Washer A-5	4									
	Q012031	Tornillo exagonal M-5x10	Screw M-5x10	4									
29	Z103030	Contactador 3TF - 2001 -3AC2	Switch contactor	1									
30	R073005	Borna portafusibes	Portafuse support	2									
	P184011	Cartucho fusible 4A.	Fuse cartridge 4A	2									
31	P453026	Borne tierra 10 (amarillo-verde)	Earth connector 10	1									
	Z103083	Guia contactor L=73	Contactador guide L=73	1									
32	Z203020	Retenedor de cable	Wires clip	1									
33	H032829	Eje de giro cuerpo	Body turning axle	1									
34	R010511	Muelle	Spring	1									
35	Q352024	Pasador de aletas Ø4x25	Colter pin Ø 4x25	2									
36	H032800	Posterior de caja completo	Rear box complete	1									
	Q221342	Remache exagonal M-5	Rivet M-5	6									
	Q032031	Tornillo alomado M-5x10	Screw M-5x10	6									
37	H032824	Soporte manguera alimentacion	Power hose support	1									
	Q221342	Remache exagonal M-5	Rivet M-5	2									
	Q232030	Arandela plana A-5	Washer A-5	2									
	Q242030	Arandela abanico A-5	Washer A-5	2									
	Q012031	Tornillo exagonal M-5x10	Screw M-5x10	2									

FPA 35

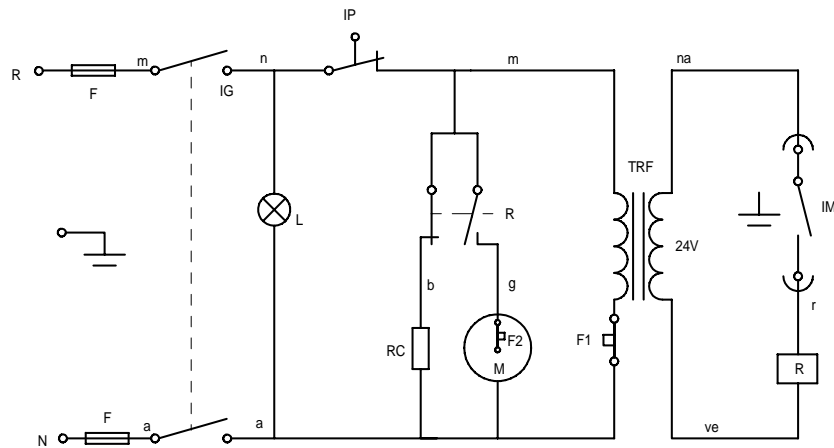

m: marron	m: marron	m: brown	m: braun	m: marrone
n: negro	n: noir	n: black	n: schwarz	n: nero
r: rojo	r: rouge	r: red	r: rot	r: rosso
b: blanco	b: blanc	b: white	b: weiss	b: bianco
g: gris	g: gris	g: grey	g: grau	g: grigio
a: azul	a: bleu	a: blue	a: blau	a: azzurro
ve: verde	ve: vert	ve: green	ve: grün	ve: verde
na: naranja	na: orange	na: orange	na: orange	na: arancione

F: Fuible
 F2:Térmico motor
 F1:Térmico transformador
 IG:Interruptor general
 IP:Micro de seguridad
 IM:Interruptor de marcha
 L:Lampara marcha
 M:Motobomba
 R:Relé
 RC:Resistencia de calentamiento



F: Fusible
 F2:Thermique moteur
 F1:Thermique transformateur
 IG:Interrupteur général
 IP:Micro sécurite
 IM:Interrupteur de marche
 L:Veilleuse mise en route
 M:Motopompe
 R:Rélais
 RC:Résistance de chauffage

F: Fuse
 F2:Motor thermic
 F1:Transformer thermic
 IG:Main switch
 IP:Position switch
 IM:Start switch
 L:Start lamp
 M:Pump
 R:Relay
 RC:Heating element

F: Sicherung
 F2:Wírme des motors
 F1:Wírme des transformators
 IG:Hauptschalter
 IP:Mikro-Sicherheitsschalter
 IM:Verlaufsschalter
 L:Funktionsleuchfè
 M:Motorpumpe
 R:Relais
 RC:Widerstandswírme

F: Fusibile
 F2:Térmico motore
 F1:Térmico transformatore
 IG:Interruptore generale
 IP:Micro sicurezza
 IM:Interruptore funzionamento
 L:Lampada funzionamento
 M:Motopompa
 R:Relé
 RC:Resistenza di riscaldamento

H-033015

Esquema teórico adhesivo				H-033015	
Nº	Pieza	Cant.	Material	Nº Clasificacion	Acabado
Nº	Modificacion		Propuesta de	Fecha	Tolerancias generales
					<5±
					5-25±
					25-50±
					50-100±
					> 100±
					∞±
Dibujado	Firma	Fecha	 Fagor Industrial,Koop.EIk, Mugatua		Mecanizado superficial
Proyectado	KONTXI	10/1/2001			
Comprobado					
Escala	<h2>FILTRO DE ACEITE</h2>				Plano numero HC-75445
Plano hau ez daiteke erabili ez berritza gure baimenitz gabe					Sustituye al N° Sustituido por