DESPIECE TECNICO

**Baño María Eléctrico
Bain Marie Électrique
Electric Bain Marie
Bagno Maria Elettrico
Banho Maria Elétrico
Elektro Bain Maries**

GAMA SNACK

Modelos:

BME6-50

Junio 2009 June



Fagor Industrial

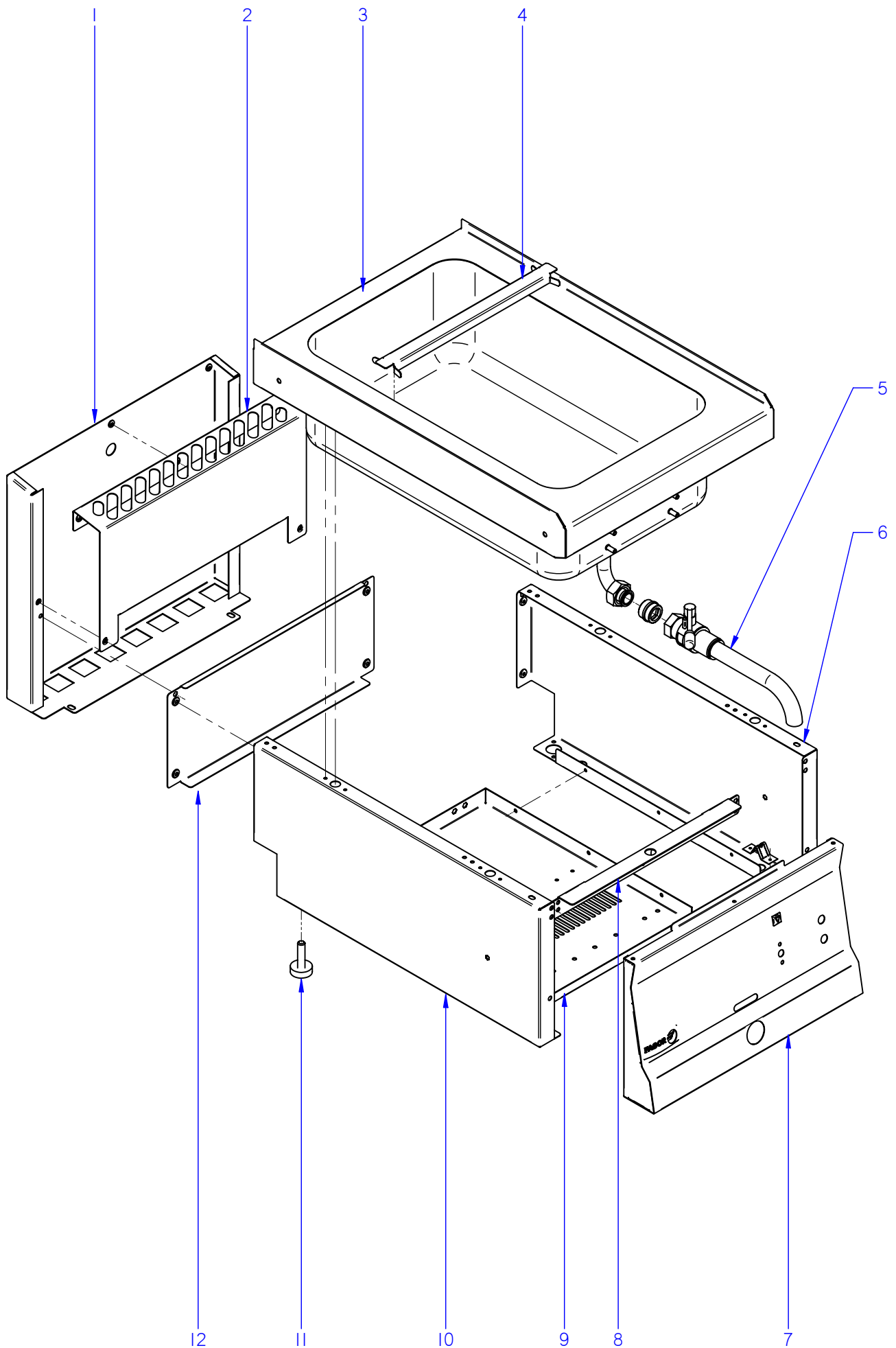

ITEM MARCADO EN COLOR = REPUESTO RECOMENDADO
 COLOURED ITEM = RECOMMENDED SPARE PART

N plano	Firma	Fecha	Aparato	MUEBLE	Lamina	Fagor Industrial S.Coop. FAGOR
C-2393	<i>[Signature]</i>	2009-06	BAÑO MARIA BME6-05		1	Oñate

MOD.		BAÑO MARIA / BAIN MARIE		ZONA	MUEBLE / UNIT				PLANO	C-2393
ITEM	CODIGO	DENOMINACION	TEXTO	BME6-05					NOTAS	
1	J142809000	PROTECC. CHIMENEA POST. 400	PROTECTION CHIMEMEY POS.	1						
	Q419005000	REMACHE 4X8 ALMG3 / ALUMINIO	RIVET 4X8 ALMG3 / ALUMINIUM	2						
2	J142810000	PROTECCION CHIMENEA ANTE. 400	PROTECTION CHIMENEY ANT	1						
	Q012031000	TORNILLO EXAGONAL M5x10 A304	HEXAGONAL BOLT M5x10 A304	4						
	Q302022000	ARANDELA 16x6x1,2 A304	WASHER 16x6x1.2 A304	4						
	Q221342000	REMACHE EXAGONAL M5	HEXAGONAL RIVET M5	3						
3	J185406000	CUBA COMPLETA BME6-05	CUBE BME6-05 COMPL.	1						
	Q221342000	REMACHE EXAGONAL M5	HEXAGONAL RIVET M5	6						
	X012612000	PITON CIERRE	LOCK SPIKE	4						
4	R966104000	SEPARADOR DE CUBETAS	TRAY DIVIDER	2						
5	J182102000	VÁLVULA PARA ACEITE	VALVE FOR OIL	1						
	J142106000	MANGUITO CONEXION GRIFO VAC.	MANGUITO CONEXION GRIFO VA	1						
	J142111000	JUNTA GRIFO VACIADO	JUNTA GRIFO VACIADO SNACK	1						
6	J002802000	PANEL LATERAL DERECHO	RIGHT SIDE PANEL	1						
	Q221342000	REMACHE EXAGONAL M5	HEXAGONAL RIVET M5	1						
	Q419007000	REMACHE TUBULAR C/V D3.2X6	TUBULAR RIVET C/V D3.2X6	8						
	X010503000	CIERRE MUELLE	LOCK SPRING	4						
7	J182802000	PORTAMANDOS COMPL. BME6-05	CONTROL HOLDER BME6-05	1						
	U022836000	ESCUDO FAGOR	FAGOR EMBLEM	1						
	Q221023000	CLIP SUJECIÓN RÁPIDA Ø5	RAPID CONNECT CLIP Ø5	2						
	Q419005000	REMACHE 4x8 ALMG3 / ALUMINIO	RIVET 4X8 ALMG3 / ALUMINIUM	6						
	Q012031000	TORNILLO EXAGONAL M5x10 A304	HEXAGONAL BOLT M5x10 A304	2						
	Q302022000	ARANDELA 16x6x1,2 A304	WASHER 16x6x1.2 A304	2						
8	J002610000	GUÍA PANEL PORTAMANDOS	GUIDE PANEL OF CONTROLS	1						
	Q221342000	REMACHE EXAGONAL M5	HEXAGONAL RIVET M5	4						
	Q012031000	TORNILLO EXAGONAL M5x10 A304	HEXAGONAL BOLT M5x10 A304	4						
9	J002604000	BASE INFERIOR FE6-05	LOWER BASE FE6-05	1						
	Q419005000	REMACHE 4X8 ALMG3 / ALUMINIO	RIVET 4X8 ALMG3 / ALUMINIUM	6						

N plano	Firma	Fecha	Aparato	Lamina	Fagor Industrial S. Coop. FAGOR Ondate
C-23394	<i>(Firma)</i>	2009-06	BAÑO MARIA BME6-05	2	

ITEM MARCADO EN COLOR = REPUESTO RECOMENDADO
 COLOURED ITEM = RECOMMENDED SPARE PART

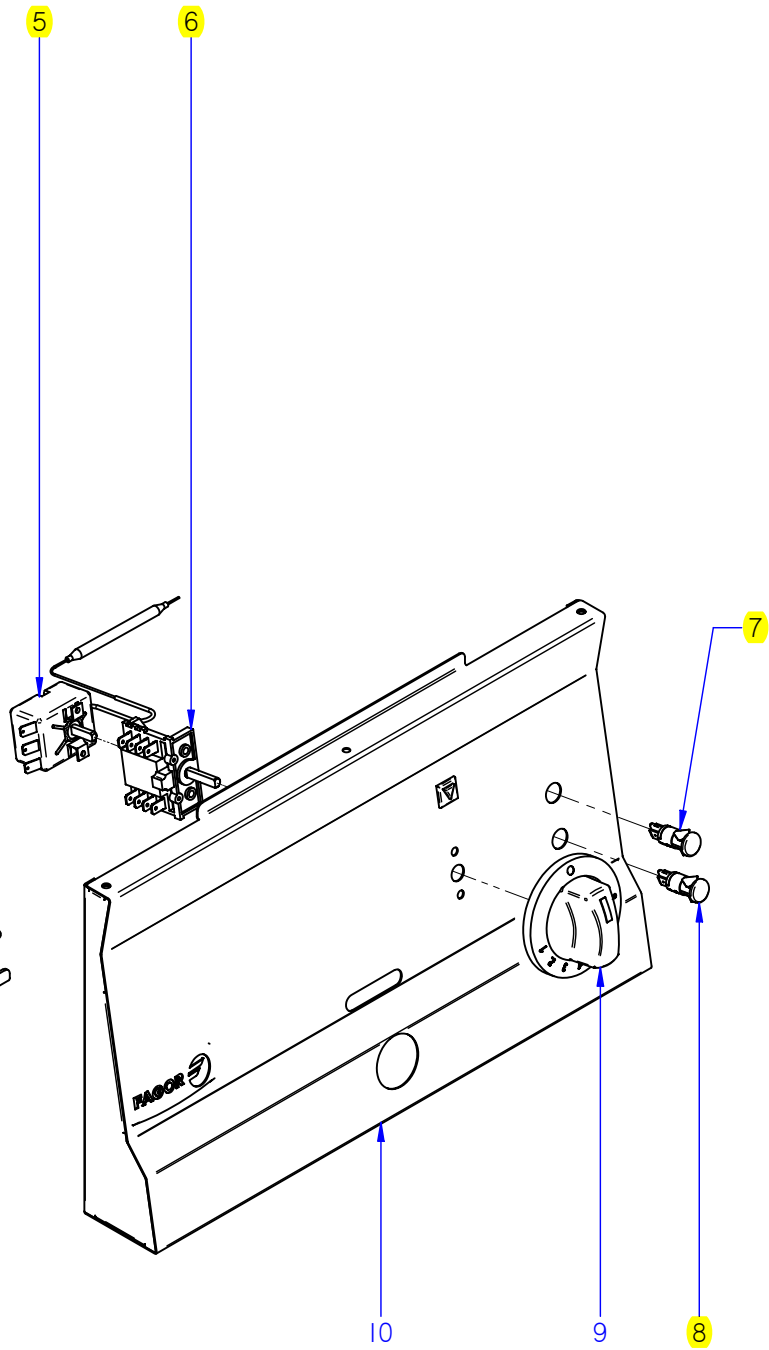
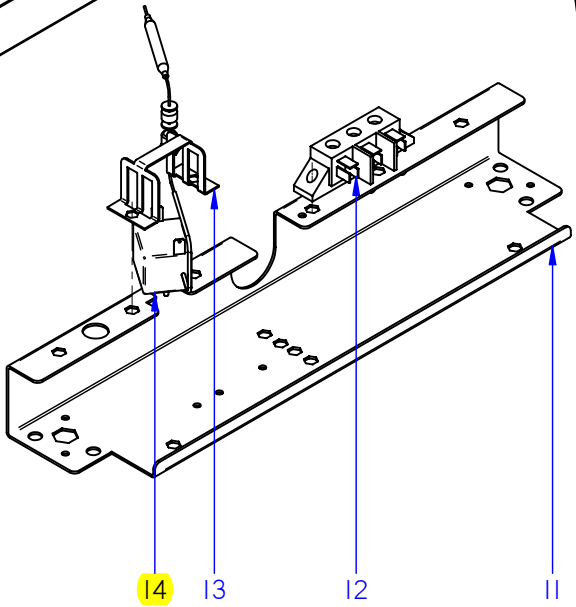
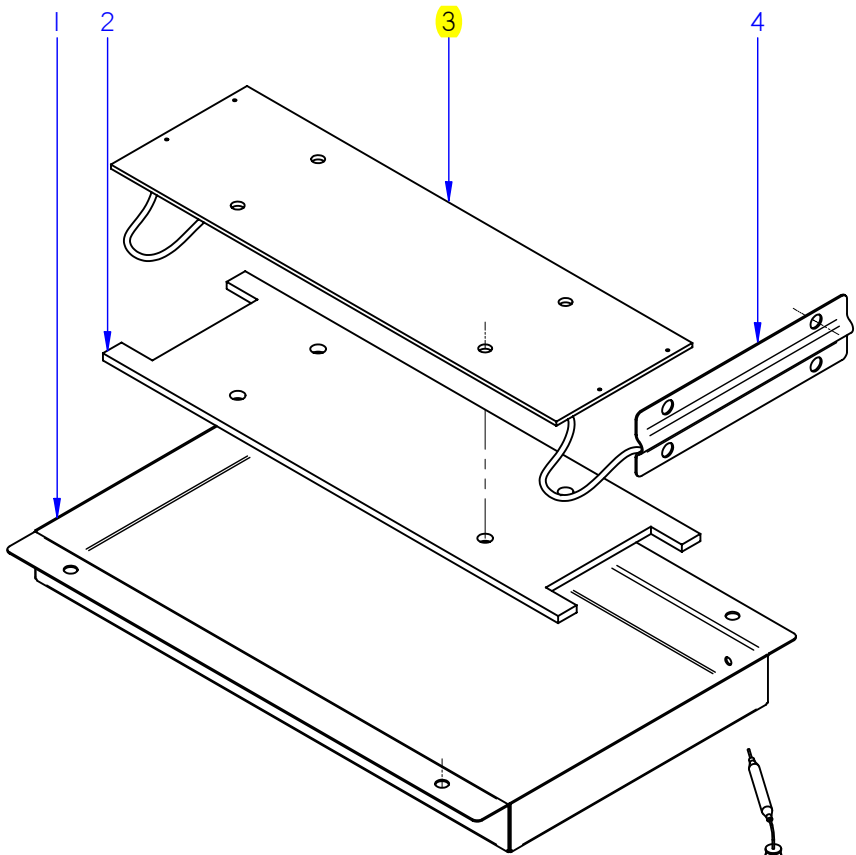

BM 6 - 05

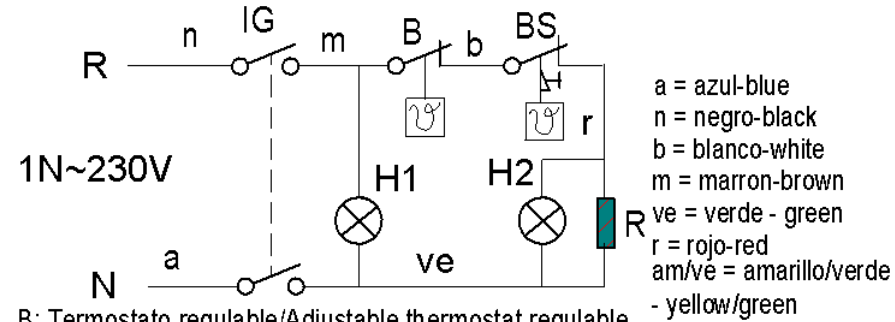

B: Termostato regulable/Adjustable thermostat regulable
 BS: Termostato de seguridad/Security thermostat R: Resistencia/Resistance
 IG: Interruptor general/Main switch H2: Luz de calentamiento/Heating lamp
 H1: Luz de encendido/Operation lamp

J183003000

-	Theoretical diagram: BM6-05		-	-	J183003000	-
Zk./N°	Pieza	Cant.	Materiala/Material	Klas. zk./N° Clas.	Gainazal akabera/Tratamiento	
Zk./N°	Aldaketa/Modificaciones		Nork proposatua/Propuesta de	Data/Fecha	Perdoi orokorrak Tolerancias generales	
-	-	-	-	-	< 5 ± 0.2	50 - 100 ± 0.8
-	-	-	-	-	5 + 25 ± 0.4	> 100 ± 1
-	-	-	-	-	25 + 50 ± 0.6	α ± 1
	Sinadura/Firma	Data/Fecha	 Fagor Industrial, Koop. Elk., Mugatua		Gainazal perdoia Mecanizado superficial	
Marratzua/Dibujado	e.carrascal	2008-10-23			-	
Proiektatua/Proyectado	e.carrascal	2008-10-23			-	
Egiaztatua/Comprobado	<i>[Signature]</i>	2008-10-23			-	
Eskala/Escala	COOKING				Plano Zk./Plano N° HB-80491	
-	Plano hau ezin daiteke erabili, ez berrizatu, gure baimenik gabe.				-	Zk. ord. du
-					-	Zk.gaitik ord.

