

**Cocinas a Gas
Fourneaux à Gaz
Gas Ranges
Cucine a Gas
Fogões a Gás
Gas-Herde**

GAMA SNACK

Modelos:

CG6-20

CG6-40

CG6-41

Junio 2009 June



Fagor Industrial

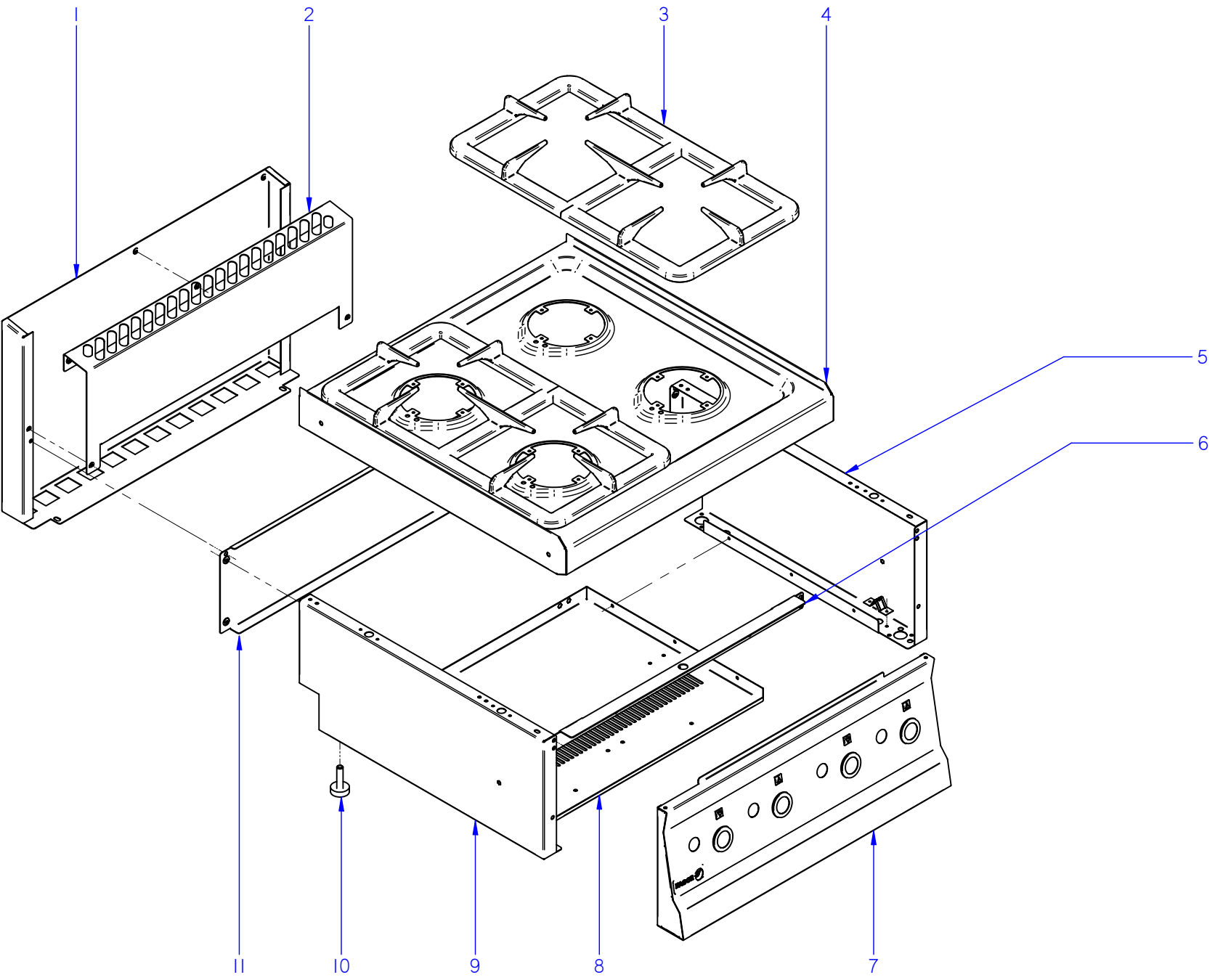

ITEM MARCADO EN COLOR = REPUESTO RECOMENDADO
 COLOURED ITEM = RECOMMENDED SPARE PART

N plano	Firma	Fecha	Aparato	MUEBLE	Lamina	Fagor Industrial S. Coop.
C-2371	<i>(Signature)</i>	2009-06	COCINAS CG6-20 / CG6-40		1	Onate
FAGOR						

MOD.		COCINAS /RANGES		ZONA	MUEBLE / UNIT				PLANO	C-2371
ITEM	CODIGO	DENOMINACION	TEXTO	CG6-20	CG6-40					NOTAS
1	J142809000	PROTECCION CHIMENEA POS. 400	PROTECTION CHIMEMEY POS.	1	-					
1	J142812000	PROTECCION CHIMENEA POS. 600	PROTECTION CHIMEMEY POS.	-	1					
	Q419005000	REMACHE 4X8 ALMG3 / ALUMINIO	RIVET 4X8 ALMG3 / ALUMINIUM	2	2					
2	J142810000	PROTECCION CHIMENEA ANTE. 400	PROTECTION CHIMENEY ANT	1	-					
2	J142813000	PROTECCION CHIMENEA ANTE. 600	PROTECTION CHIMENEY ANT	-	1					
	Q012031000	TORNILLO EXAGONAL M5x10 A304	HEXAGONAL BOLT M5x10 A304	4	4					
	Q302022000	ARANDELA 16x6x1,2 A304	WASHER 16x6x1.2 A304	4	4					
	Q221342000	REMACHE EXAGONAL M5	HEXAGONAL RIVET M5	3	3					
3	J015405000	PARRILLA SNACK	PARRILLA SNACK	1	2					
4	J015410000	ENCIMERA CG6-20 COMPL.	TOP CG6-20 COMPL.	1	-					
4	J015411000	ENCIMERA CG6-40 COMPL.	TOP CG6-40 COMPL.	-	1					
	Q221342000	REMACHE EXAGONAL M5	HEXAGONAL RIVET M5	4	4					
	X012612000	PITON CIERRE	LOCK SPIKE	4	4					
	Q221342000	REMACHE EXAGONAL M5	HEXAGONAL RIVET M5	2	2					
5	J002802000	PANEL LATERAL DERECHO	RIGHT SIDE PANEL	1	1					
	Q221342000	REMACHE EXAGONAL M5	HEXAGONAL RIVET M5	1	1					
	Q419007000	REMACHE TUBULAR C/V D3.2X6	TUBULAR RIVET C/V D3.2X6	8	8					
	X010503000	CIERRE MUELLE	LOCK SPRING	4	4					
6	J002610000	GUÍA PANEL PORTAMANDOS	GUIDE PANEL OF CONTROLS	1	-					
6	J002612000	GUÍA PANEL PORTAMANDOS 600	GUIDE PANEL OF CONTROLS	-	1					
	Q221342000	REMACHE EXAGONAL M5	HEXAGONAL RIVET M5	4	4					
	Q012031000	TORNILLO EXAGONAL M5x10 A304	HEXAGONAL BOLT M5x10 A304	4	4					
7	J012802000	PORTAMANDOS COMPL. CG6-20	CONTROL HOLDER CG6-20	1	-					
7	J012804000	PORTAMANDOS COMPL. CG6-40	CONTROL HOLDER CG6-40	-	1					
	U022836000	ESCUDO FAGOR	FAGOR EMBLEM	1	1					
	Q221023000	CLIP SUJECIÓN RÁPIDA Ø5	RAPID CONNECT CLIP Ø5	2	2					
	Q419005000	REMACHE 4x8 ALMG3 / ALUMINIO	RIVET 4X8 ALMG3 / ALUMINIUM	6	6					
	Q012031000	TORNILLO EXAGONAL M5x10 A304	HEXAGONAL BOLT M5x10 A304	2	2					
	Q302022000	ARANDELA 16x6x1,2 A304	WASHER 16x6x1.2 A304	2	2					

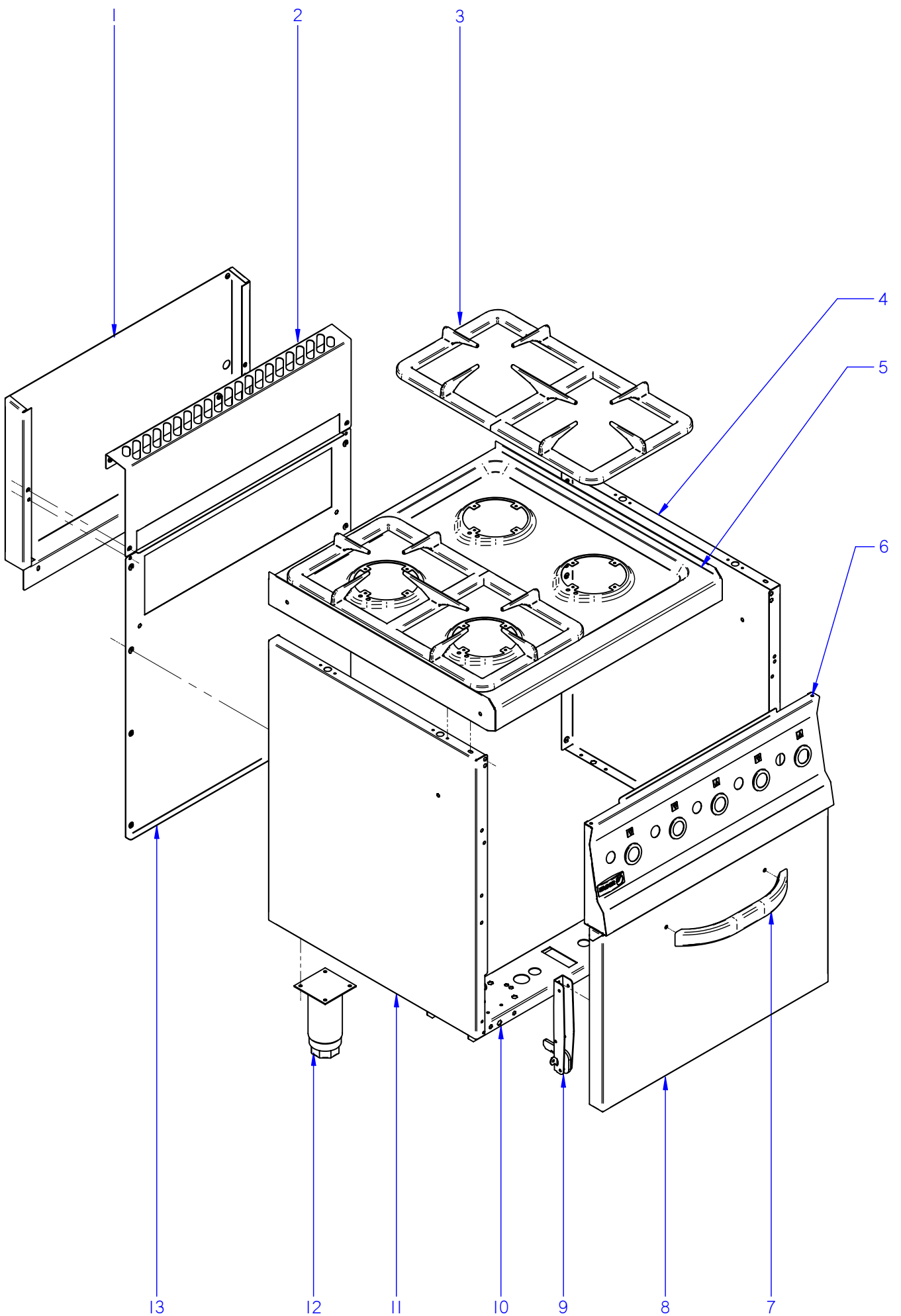

ITEM MARCADO EN COLOR = REPUESTO RECOMENDADO
 COLOURED ITEM = RECOMMENDED SPARE PART

N plano	Firma	Fecha	Aparato	MUEBLE	Lamina	Fagor Industrial S.Coop. FAGOR
C-2372	<i>(Signature)</i>	2009-06	COCINA CG6-41		2	Oñate

MOD.	COCINAS /RANGES		ZONA	MUEBLE / UNIT				PLANO	C-2372
ITEM	CODIGO	DENOMINACION	TEXTO	CG6-41					NOTAS
1	J042801000	PROTECCION CHIMENEA POST.	PROTECTION CHIMEMEY POS.	1					
	Q419005000	REMACHE 4X8 ALMG3 / ALUMINIO	RIVET 4X8 ALMG3 / ALUMINIUM	2					
2	J142813000	PROTECCION CHIMENEA ANTE.	PROTECTION CHIMENEY ANT	1					
	Q012031000	TORNILLO EXAGONAL M5x10 A304	HEXAGONAL BOLT M5x10 A304	4					
	Q302022000	ARANDELA 16x6x1,2 A304	WASHER 16x6x1.2 A304	4					
3	J015405000	PARRILLA SNACK	PARRILLA SNACK	2					
4	J022802000	PANEL LATERAL DCHO CG6-41	LATERAL RIGHT RANGE CG6-41	1					
	Q419005000	REMACHE 4X8 ALMG3 / ALUMINIO	RIVET 4X8 ALMG3 / ALUMINIUM	4					
	X010503000	CIERRE MUELLE	LOCK SPRING	2					
	Q419007000	REMACHE TUBULAR C/V D3.2X6	TUBULAR RIVET C/V D3.2X6	4					
	Q221342000	REMACHE EXAGONAL M5	HEXAGONAL RIVET M5	1					
5	J015411000	ENCIMERA CG6-40 COMPL.	TOP CG6-40 COMPL.	1					
	Q221342000	REMACHE EXAGONAL M5	HEXAGONAL RIVET M5	4					
	X012612000	PITON CIERRE	LOCK SPIKE	4					
	Q221342000	REMACHE EXAGONAL M5	HEXAGONAL RIVET M5	2					
6	J022807000	PORTAMANDOS COMPL. CG6-41	CONTROL HOLDER CG6-41	1					
	U022836000	ESCUDO FAGOR	FAGOR EMBLEM	1					
	Q221023000	CLIP SUJECIÓN RÁPIDA Ø5	RAPID CONNECT CLIP Ø5	2					
	Q419005000	REMACHE 4x8 ALMG3 / ALUMINIO	RIVET 4X8 ALMG3 / ALUMINIUM	6					
	Q012031000	TORNILLO EXAGONAL M5x10 A304	HEXAGONAL BOLT M5x10 A304	2					
	Q302022000	ARANDELA 16x6x1,2 A304	WASHER 16x6x1.2 A304	2					
7	Z400542000	ASA LVS.	HANDLE LVS.	1					
	Q012041000	TORNILLO EXAGONAL M6x10	HEXAGONAL BOLT M6x10	2					
	Q302022000	ARANDELA 16x6x1,2 A304	WASHER 16x6x1.2 A304	2					
8	J040501000	PUERTA DE HORNO	OVEN DOOR	1					
9	U020528000	BISAGRA CIERRE HORNO	OVEN LOCK HINGE	2					
	Q152022000	TORNILLO M6x8	BOLT M6x8	6					
10	J002613000	LISTON SOPORTE PATAS	TIEDOWN SUPPORTS MB6-40	2					
	Q221343000	REMACHE EXAGONAL M6	HEXAGONAL RIVET M6	4					

N plano	Firma	Fecha	Aparato	CONJUNTO FUNCIONAL	Lamina	Fagor Industrial S. Coop.
C-2373	<i>(Firma)</i>	2009-06	COCINAS CG6-20 / CG6-40 / CG6-41		3	Onate
FAGOR						

ITEM MARCADO EN COLOR = REPUESTO RECOMENDADO
 COLOURED ITEM = RECOMMENDED SPARE PART

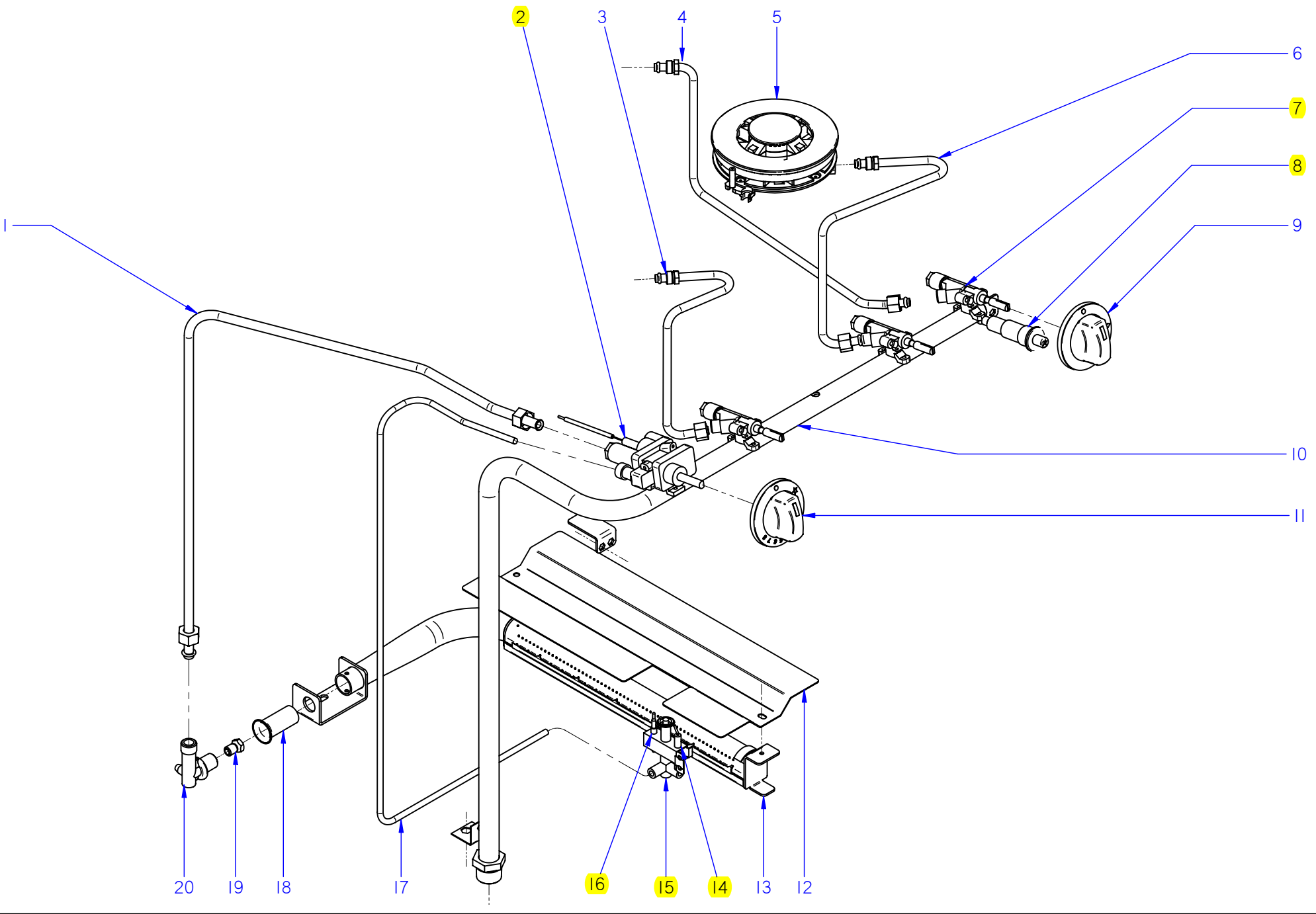

MOD.		COCINAS /RANGES		ZONA	CONJUNTO FUNCIONAL / FUNCTIONAL UNIT			PLANO	C-2373	
ITEM	CODIGO	DENOMINACION	TEXTO	CG6-20	CG6-40	CG6-41				NOTAS
1	J025011000	COND. QUEMADOR CG6-41 SNACK	COND. BURNER CG6-41 SNACK	-	-	1				
2	U742130000	TERMOSTATO MTZ-7200-0.5	THERMOSTAT MTZ-7200-0.5	-	-	1				
S/Nº	Z982018000	BRIDA AMARRE TERMOSTATO	FASTENING FLANGE TERMOST	2	4	5				
	Q011353000	TORNILLO EXAGONAL M5X30	HEXAGONAL BOLT M5X30	4	8	10				
3	J015017000	COND. QUEMADOR ANTERIOR	COND. FRONT BURNER	1	2	-				
3	J025015000	COND. QUEMADOR ANTER. IZDO.	COND. LEFT FRONT BURNER.	-	-	1				
4	J015015000	COND. QUEMADOR POSTERIOR	COND. REAR BURNER	1	2	2				
5	J015702000	SUPERIOR QUEMADOR BSI	TOP BURNER BSI	2	4	4				
S/Nº	J015710000	BASE QUEMADOR C/TOBERA	BURNER BASE W/NOZZLE	2	4	4				
S/Nº	J015708000	INYECTOR G30/29 G-N	INJECTOR G30/29 G-N	2	4	4				
S/Nº	J012104000	TERMOPAR L=650 COCINA SNACK	THERMOCOUPLE L=650	2	4	4				
	Q161371000	TUERCA EXAGONAL M6X0,75	HEXAGONAL NUT M6X0,75	2	4	4				
S/Nº	J015705000	TAPA SUPERIOR Ø127	UPPER COVER Ø127	2	4	4				
S/Nº	J015704000	TAPON SUPERIOR Ø55	UPPER LID Ø55	2	4	4				
	Q032012000	TORNILLO ALOMADO M3X15	CURVED SCREW M3X15	8	16	16				
6	J025013000	COND. QUEMADOR ANTER. DCHO.	COND. RIGHT FRONT BURNER.	-	-	1				
7	J012101000	GRIFO CAL 20703	TAP CAL 20703	2	4	4				
8	S113034000	PIEZOELECTRICO	PIEZOELECTRIC	2	4	5				
S/Nº	U333003000	CABLE MASA ENCENDEDOR	LIGHTER EARTH CABLE	2	4	5				
S/Nº	R613030000	CABLE BUJIA	SPARK PLUG CABLE	2	4	5				
9	J012102000	MANDO COCINA SNACK GAS	BOTON RANGE GAS SNACK	2	4	4				
10	J015002000	CONDUCCION GENERAL CG6-20	GENERAL PIPE CG6-20	1	-	-				
10	J015005000	CONDUCCION GENERAL CG6-40	GENERAL PIPE CG6-40	-	1	-				
10	J025003000	CONDUCCION GENERAL CG6-41	GENERAL PIPE CG6-41	-	-	1				
	Q302022000	ARANDELA 16x6x1,2 A304	WASHER 16x6x1.2 A304	6	6	3				
	Q221342000	REMACHE EXAGONAL M5	HEXAGONAL RIVET M5	2	2	2				
	Q012031000	TORNILLO EXAGONAL M5x15 A304	HEXAGONAL BOLT M5x15 A304	6	6	2				
	Q012042000	TORNILLO EXAGONAL M6X15	HEXAGONAL BOLT M6X15	-	-	1				
	Q221343000	REMACHE EXAGONAL M6	HEXAGONAL RIVET M6	-	-	1				
11	J022102000	MANDO HORNO GAS SNACK	BOTONOVEN GAS SNACK	-	-	1				
12	J022604000	DEFLECTOR QUEMADOR SNACK	OVEN BURNER DEFLECTOR	-	-	1				

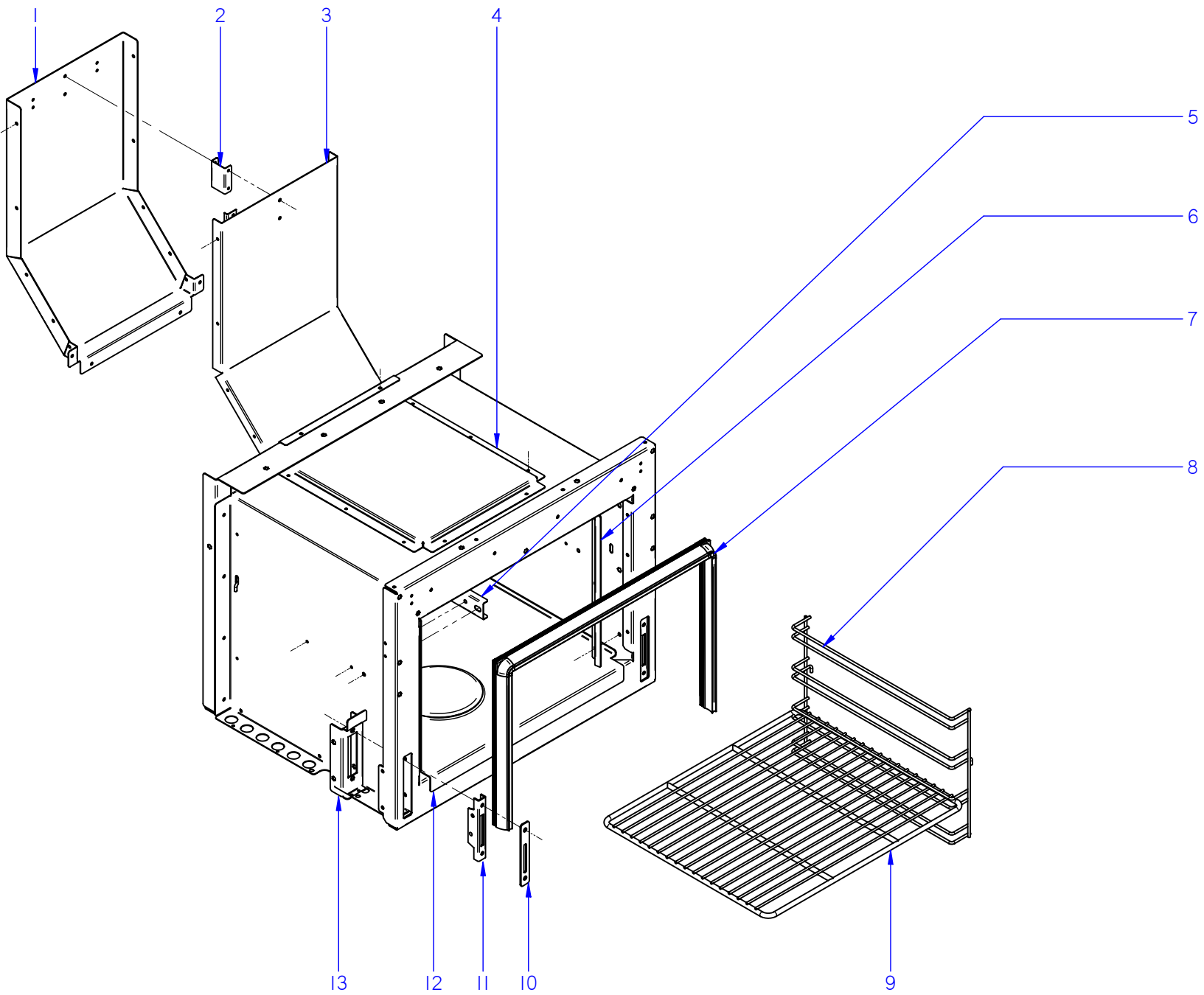

ITEM MARCADO EN COLOR = REPUESTO RECOMENDADO
COLOURED ITEM = RECOMMENDED SPARE PART

N plano	Firma	Fecha	Aparato	HORNO	Lamina	Fagor Industrial S. Coop. FAGOR
C-2374	<i>(Firma)</i>	2009-06	COCINA CG6-41		4	Onate

MOD.		COCINAS /RANGES		ZONA	HORNO / OVEN				PLANO	C-2374
ITEM	CODIGO	DENOMINACION	TEXTO	CG6-41					NOTAS	
1	J022602000	POSTERIOR CHIMENEA CG6-41	REAR FLUEPIPE CG6-41	1						
	Q419005000	REMACHE 4X8 ALMG3 / ALUMINIO	RIVET 4X8 ALMG3 / ALUMINIUM	4						
2	J022608000	SEPAR. CHIMENEA HORNO SNACK	SEPAR. OVEN FLUEPIPE SNACK	1						
	Q419005000	REMACHE 4X8 ALMG3 / ALUMINIO	RIVET 4X8 ALMG3 / ALUMINIUM	4						
3	J022603000	ANTERIOR CHIMENEA CG6-41	FRONT FLUEPIPE CG6-41	1						
	Q419005000	REMACHE 4X8 ALMG3 / ALUMINIO	RIVET 4X8 ALMG3 / ALUMINIUM	12						
4	J022606000	CHIMENEA SUPERIOR HORNO	UPPER FLUEPIPE OVEN	1						
	Q419005000	REMACHE 4X8 ALMG3 / ALUMINIO	RIVET 4X8 ALMG3 / ALUMINIUM	8						
5	U055644000	FIJACION BULBO	FASTENING BULB	1						
	Q412000000	REMACHE TUBULAR 4x8	TUBULAR RIVET 4x8	2						
6	J045610000	SUJECCION JUNTA PUERTA SNACK	DOOR SEAL FASTENING SNACK	2						
	Q012031000	TORNILLO EXAGONAL M5x10 A304	HEXAGONAL BOLT M5x10 A304	6						
	Q302022000	ARANDELA 16x6x1,2 A304	WASHER 16x6x1.2 A304	6						
7	J025610000	JUNTA HORNO COMPL.SNACK	OVEN DOOR SEAL SNACK	1						
8	J045609000	GUIA BANDEJAS HORNO SNACK	OVEN TRAY GUIDE SNACK	2						
9	J045613000	PARRILLA DE HORNO SNACK	SNACK OVEN GRILLE	1						
10	J045612000	EMBELLEC. GUIA BISAGRA SNACK	TRIM HINGE GUIDE SNACK	4						
	Q152045000	TORNILLO AMARRE M6X25	FASTENING BOLT M6X25	4						
11	U010512000	GUIA DE BISAGRA	HINGE GUIDE	2						
12	J025607000	SOLERA DE HORNO GAS SNACK	GAS OVEN FLOOR SNACK	1						
S/Nº	U915618000	TAPILLA DE SOLERA G 700	BASE COVER G 700	1						
13	J042604000	SOPOR. BISAGRA PUERTA HORNO	SUPPORT OVEN DOOR HINGE	2						
	Q221342000	REMACHE EXAGONAL M5	HEXAGONAL RIVET M5	4						
	Q419005000	REMACHE 4X8 ALMG3 / ALUMINIO	RIVET 4X8 ALMG3 / ALUMINIUM	2						
	Q012031000	TORNILLO EXAGONAL M5X10 A304	HEXAGONAL BOLT M5X10 A304	2						
	Q302022000	ARANDELA Ø16X6X1.2 A.304	WASHER 16X6X1.2 A.304	5						

