

**Cocedor de Pasta Eléctrico
Cuiser à Pâtes Électrique
Electric Pasta Cooker
Cuocipasta Elettrico
Cozedor de Massa Eléctrico
Elektro Nudelkocher**

GAMA SNACK

Modelos:

CPE6-05

Junio 2009 June



Fagor Industrial

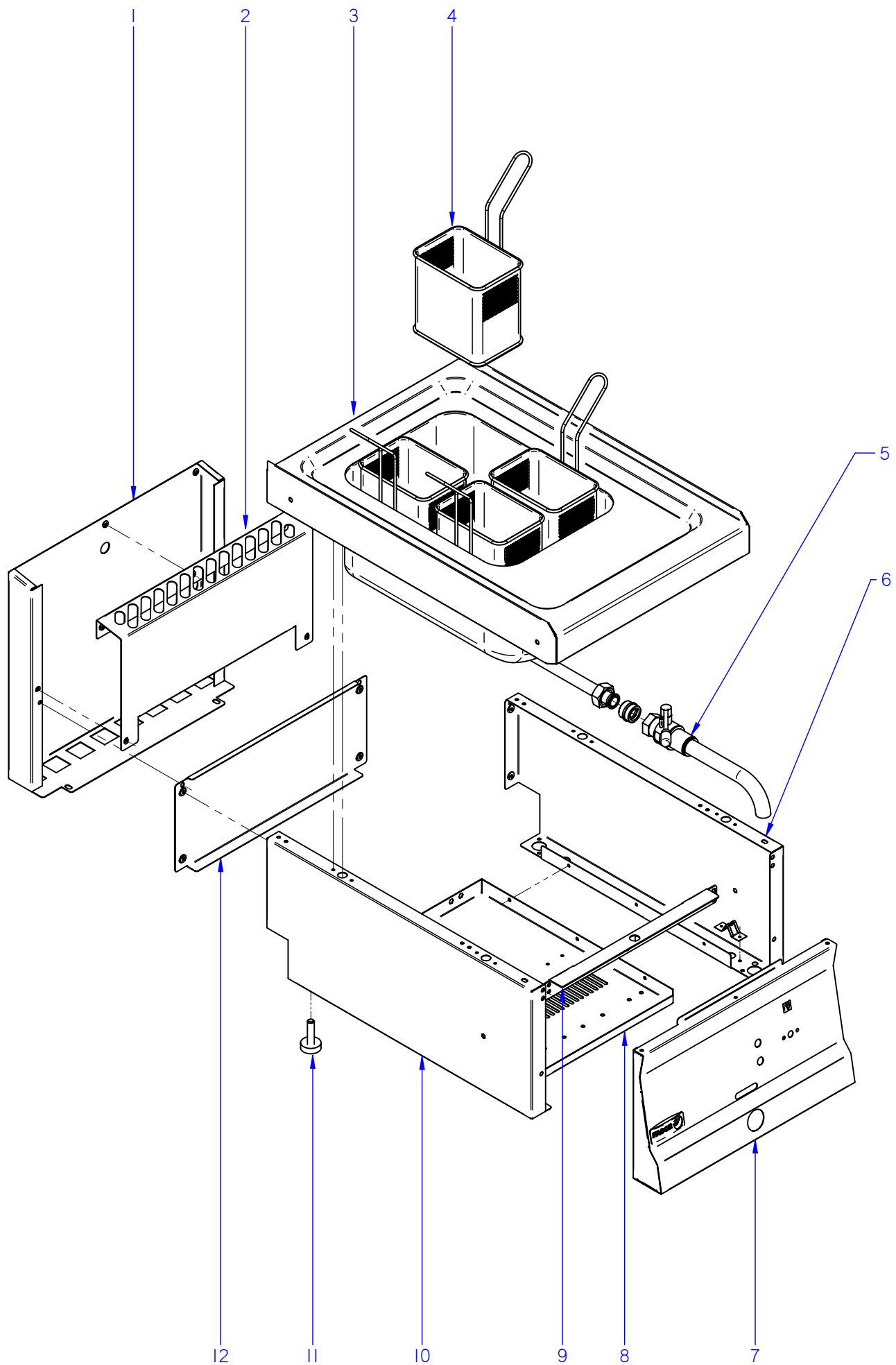

ITEM MARCADO EN COLOR = REPUESTO RECOMENDADO
 COLOURED ITEM = RECOMMENDED SPARE PART

N plano	Firma	Fecha	Aparato	MUEBLE	Lamina	Fagor Industrial S.Coop. FAGOR
C-2395	<i>(Signature)</i>	2009-06	COCEDOR DE PASTA CPE6-05		1	Oñate

MOD.		COCEDOR DE PASTA / PASTA COOKER		ZONA	MUEBLE / UNIT				PLANO	C-2395
ITEM	CODIGO	DENOMINACION	TEXTO	CPE6-05					NOTAS	
1	J142809000	PROTECC. CHIMENEA POST. 400	PROTECTION CHIMEMEY POS.	1						
	Q419005000	REMACHE 4X8 ALMG3 / ALUMINIO	RIVET 4X8 ALMG3 / ALUMINIUM	2						
2	J142810000	PROTECCION CHIMENEA ANTE. 400	PROTECTION CHIMENEY ANT	1						
	Q012031000	TORNILLO EXAGONAL M5x10 A304	HEXAGONAL BOLT M5x10 A304	4						
	Q302022000	ARANDELA 16x6x1,2 A304	WASHER 16x6x1.2 A304	4						
	Q221342000	REMACHE EXAGONAL M5	HEXAGONAL RIVET M5	3						
3	J215407000	CUBA COMPLETA CPE6-05	CUBE CPE6-05 COMPL.	1						
	Q221342000	REMACHE EXAGONAL M5	HEXAGONAL RIVET M5	6						
	X012612000	PITON CIERRE	LOCK SPIKE	4						
4	J216504000	CESTILLO SNACK CPE6-05	BASKET CPE6-05	4						
5	J182102000	VÁLVULA PARA ACEITE	VALVE FOR OIL	1						
	J142106000	MANGUITO CONEXION GRIFO VAC.	MANGUITO CONEXION GRIFO VA	1						
	J142111000	JUNTA GRIFO VACIADO	JUNTA GRIFO VACIADO SNACK	1						
6	J002802000	PANEL LATERAL DERECHO	RIGHT SIDE PANEL	1						
	Q221342000	REMACHE EXAGONAL M5	HEXAGONAL RIVET M5	1						
	Q419007000	REMACHE TUBULAR C/V D3.2X6	TUBULAR RIVET C/V D3.2X6	8						
	X010503000	CIERRE MUELLE	LOCK SPRING	4						
7	J212803000	PORTAMANDOS COMPL. CPE6-05	CONTROL HOLDER CPE6-05	1						
	U022836000	ESCUDO FAGOR	FAGOR EMBLEM	1						
	Q221023000	CLIP SUJECIÓN RÁPIDA Ø5	RAPID CONNECT CLIP Ø5	2						
	Q419005000	REMACHE 4x8 ALMG3 / ALUMINIO	RIVET 4X8 ALMG3 / ALUMINIUM	6						
	Q012031000	TORNILLO EXAGONAL M5x10 A304	HEXAGONAL BOLT M5x10 A304	2						
	Q302022000	ARANDELA 16x6x1,2 A304	WASHER 16x6x1.2 A304	2						
8	J002604000	BASE INFERIOR 400 ELECTRIC,	LOWER BASE 400 ELECTRIC,	1						
	Q419005000	REMACHE 4X8 ALMG3 / ALUMINIO	RIVET 4X8 ALMG3 / ALUMINIUM	6						
9	J002610000	GUÍA PANEL PORTAMANDOS	GUIDE PANEL OF CONTROLS	1						
	Q221342000	REMACHE EXAGONAL M5	HEXAGONAL RIVET M5	4						
	Q012031000	TORNILLO EXAGONAL M5x10 A304	HEXAGONAL BOLT M5x10 A304	4						

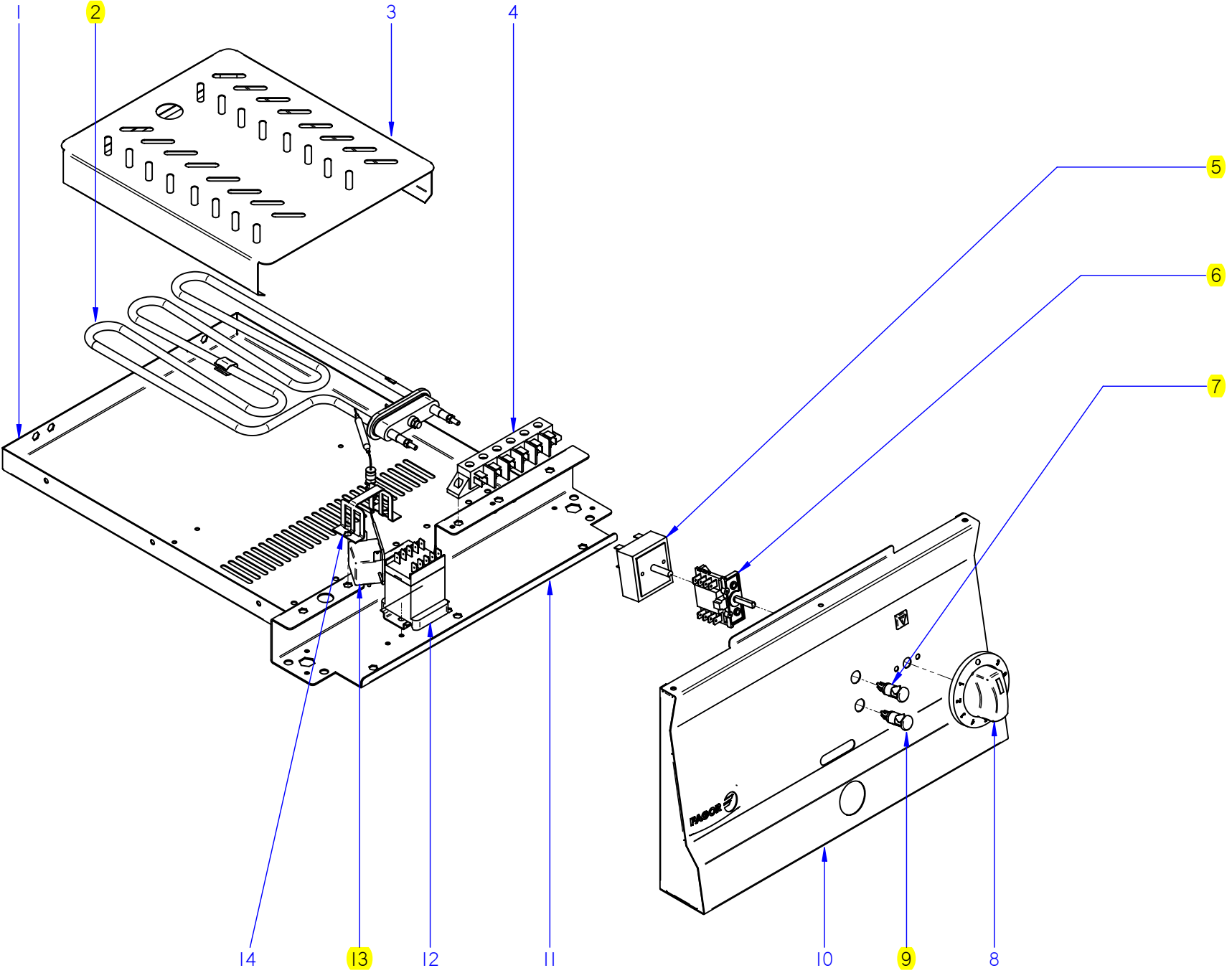

ITEM MARCADO EN COLOR = REPUESTO RECOMENDADO
 COLOURED ITEM = RECOMMENDED SPARE PART

N plano	Firma	Fecha	Aparato	Lamina	Fagor Industrial S. Coop.
C-2396	<i>(Firma)</i>	2009-06	COCEDOR DE PASTA	2	ONATE
CONJUNTO FUNCIONAL					



CPE 6-05

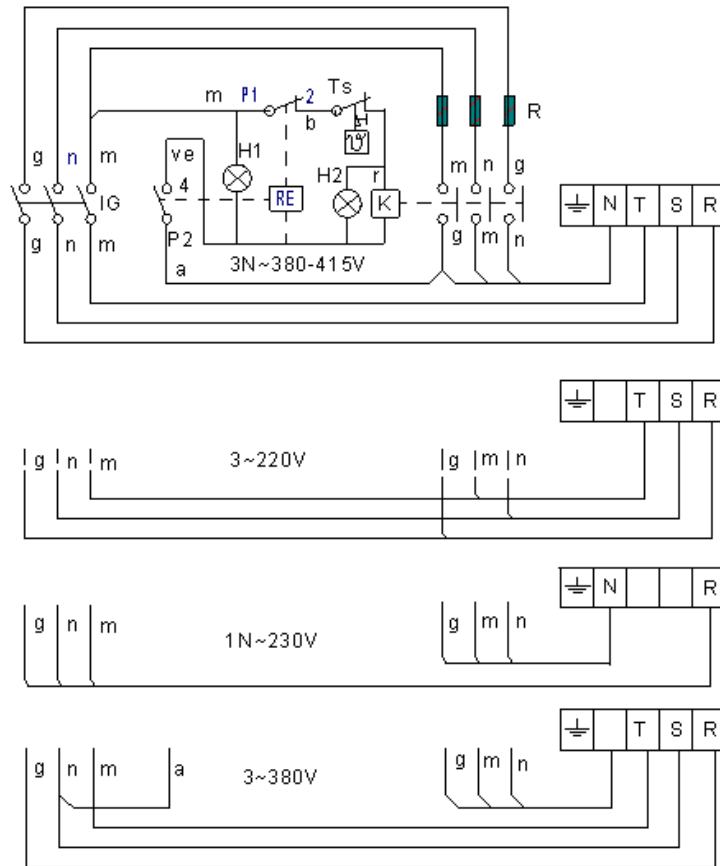

r = rojo / red
 m = marron / brown
 g = gris / grey
 n = negro / black
 a = azul / blue
 b = blanco / white
 am/ve = amarillo-verde / Yellow-green

J213001000

POSICIÓN	±2%	P1 - 2		P2 - 4	S1 - S2
		TO	TO + TO F		
0	0	0	∞		
52°	8%	3"	45"	X	X
84°	10%	4"	38"	X	X
118°	15%	5"	32"	X	X
148°	25%	7"	29"	X	X
180°	30%	9"	30"	X	X
212°	40%	13"	32"	X	X
244°	55%	21"	37"	X	X
276°	75%	45"	60"	X	X
308°	100%	∞	∞	X	X

IG : Interruptor general / Main switch
 H1 : Lámpara funcionamiento / Operating lamp
 H2 : Lámpara calentamiento / Heating Lamp
 K : Contactor de calentamiento / heating contactor
 R : Resistencia de Calentamiento / Resistance heating
 RE : Regulador de energía / Energy Regulatory
 Ts : Termostato de seguridad / Hi-limit thermostat

-	Theoretical diagram: CPE6-05	-	-	J213001000	-	
Zk./N°	Peza	Cost.	Materiaia/Material	Klas. di./N° Clas	Gaiazal akabera/Traitam. k. rto	
Zk./N°	Aldaketak/Modifikazioak		Notik. proposatuta/Propuesta de	Data/Fecha	Perdioronokorralak Tolerantziak generales	
-	-	-	-	-	-	
-	-	-	-	-	+ 5 ± 0.2 50 + 100 ± 0.8	
-	-	-	-	-	5 + 25 ± 0.4 = 100 ± 1	
-	-	-	-	-	25 + 50 ± 0.6 0.1 ± 1	
-	-	-	-	-	-	
	Siadria/Firma	Data/Fecha	 Fagor Industrial, Koop. Ek., Migatza		Gaiazal pertsoala Mecanizado superficial	
	Marraztea/Dibujado	e.carrascal 2008-10-24				
	Proiektatza/Proyectado	e.carrascal 2008-10-24				
	Egiaztatza/Comprobado	I. Alcega 2008-10-24				
	Eskala/Escala	-	COOKING		Plano di./Plano N° HC-81132	
	-	-			-	Zk. ord. di
	Plano kate ezin daiteke erabili, ez bezarritatu, gure balizkigabe.					Zk. gaitik ord.

