

**Hornos Mixtos
Fours Mixtes
Combi Ovens
HeiBluftdämpfer
Forno Misti**

Modelos:

COE-202

VE-202

VPE-202

Octubre 2009 October



Fagor Industrial

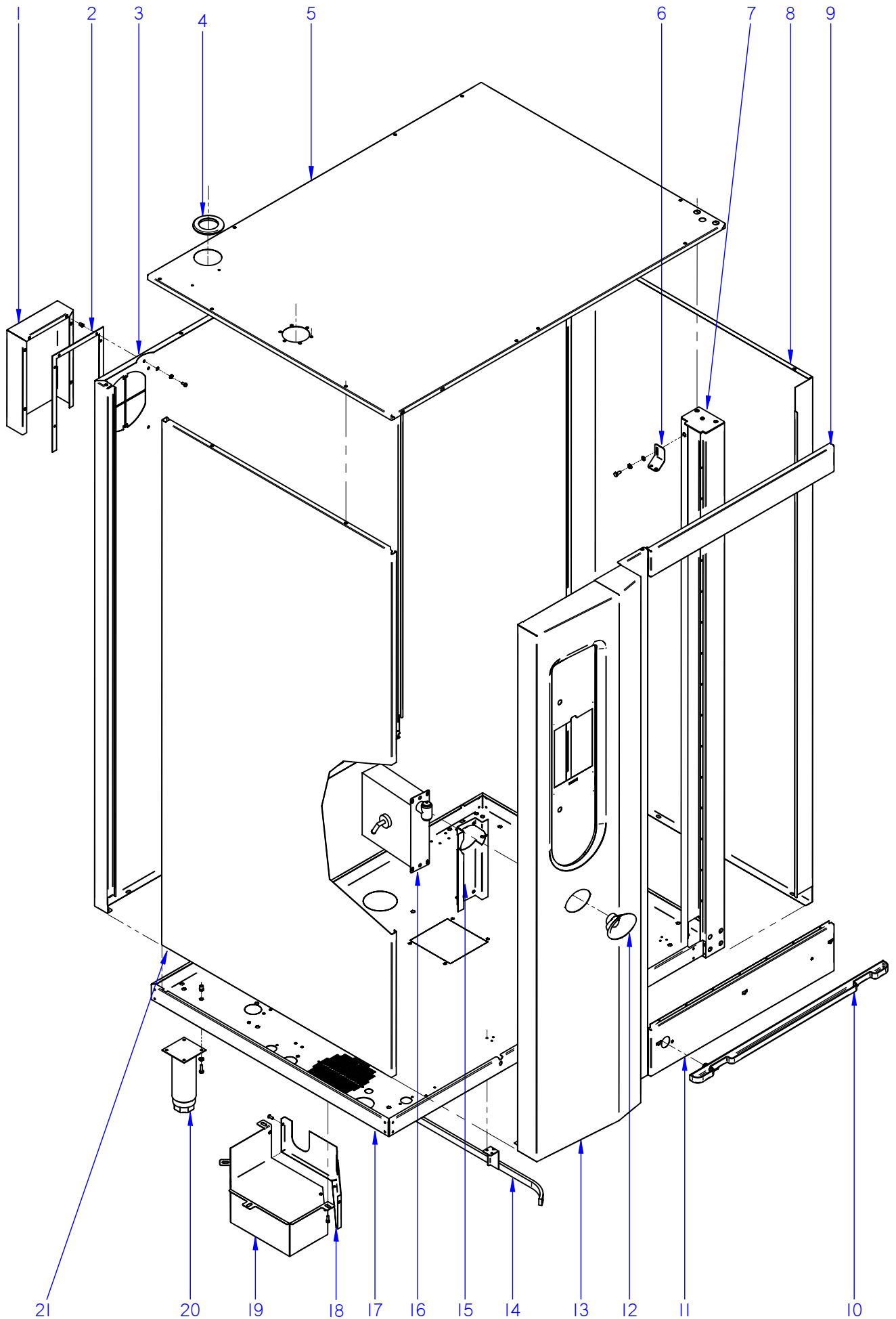

ITEM MARCADO EN COLOR = REPUESTO RECOMENDADO
 COLOURED ITEM = RECOMMENDED SPARE PART

N plano	Firma	Fecha	Aparato	MUEBLE	Lamina	Fagor Industrial S.Coop. FAGOR
C-2438	<i>name (benj)</i>	2009-10	HORNOS COE / VE / VPE-202		1	Oñate

MOD.		HORNOS / OVEN		ZONA	MUEBLE / UNIT			PLANO	C-2438
ITEM	CODIGO	DENOMINACION	TEXTO	COE-202	VE-202	VPE-202			NOTAS
1	T512807500	CHAPA SEPARACION IPX5	SEPARATION PLATE IPX5	1	1	1			
	Q221342000	REMACHE EXAGONAL M5	HEXAGONAL RIVET M.5	6	6	6			
	Q232030000	ARANDELA A5	WASHER A.5	6	6	6			
	Q242030000	ARANDELA ABANICO A5 A.304	FAN SHAPED WASHER A.5	6	6	6			
	Q012031000	TORNILLO EXAGONAL M5x10 A304	HEXAGONAL SCREW M.5x10	6	6	6			
2	T512808000	JUNTA IPX5	SEAL IPX5	1	1	1			
3	T512803000	PANEL POST. EXTERIOR 20/21	REAR EXTERIOR PANEL210/21	1	1	1			
4	R662813000	PASAMUROS CHIMENEA 101003361	FEED THROUGH FLUE PIPE 1010	1	1	1			
5	T512805000	PANEL SUPER. EXTERIOR 20/21	SUP. EXTERIOR PANEL20/21	1	1	1			
	Q232040000	ARANDELA A6	WASHER A.6	7	7	7			
	Q242040000	ARANDELA ABANICO A6 A.304	FAN SHAPED WASHER A.6	7	7	7			
	Q012042000	TORNILLO EXAGONAL M6x15	HEXAGONAL BOLT M6x15	7	7	7			
	Q152004000	TORNIL. APLASTADO M5X13 A 304	FLAT SCREW M.5x13	7	7	7			
6	T642821000	ESCUADRA SOPORTE	SUPPORT SQUARE	1	1	1			
	Q232040000	ARANDELA A6	WASHER A.6	5	5	7			
	Q242040000	ARANDELA ABANICO A6 A.304	FAN SHAPED WASHER A.6	5	5	5			
	Q012042000	TORNILLO EXAGONAL M6x15	HEXAGONAL BOLT M6x15	3	3	3			
	Q162040000	TUERCA EXAGONAL M6	HEXAGONAL NUT M6	2	2	2			
7	T542804000	PANEL SOPORTE PUERTA 202	SUPPORT PANEL DOOR 202	1	1	1			
8	T542806000	PANEL EXTERIOR DERECHO 20/21	RIGHT EXT. PANEL 20/21	1	1	1			
	Q221342000	REMACHE EXAGONAL M5	HEXAGONAL RIVET M.5	2	2	2			
9	T642810000	PANEL FRONTAL SUPERIOR	UPPER FRONT PANEL	1	1	1			
	Q221342000	REMACHE EXAGONAL M5	HEXAGONAL RIVET M.5	2	2	2			
	Q412005000	REMACHE AVINOX Ø 3,2X6	AVINOX RIVET Ø 3,2X6	7	7	7			
	Q232040000	ARANDELA A6	WASHER A.6	6	6	6			
	Q242040000	ARANDELA ABANICO A6 A.304	FAN SHAPED WASHER A.6	6	6	6			
	Q012042000	TORNILLO EXAGONAL M6x15	HEXAGONAL BOLT M6x15	6	6	6			

MOD.		HORNOS / OVEN		ZONA	MUEBLE / UNIT			PLANO	C-2438
ITEM	CODIGO	DENOMINACION	TEXTO	COE-202	VE-202	VPE-202			NOTAS
10	T452830000	RECOGEAGUAS PLASTICO	PLAST SPRING WATER COLLE.	1	1	1			
	Q222041000	REMACHE EXAGONAL M.4 INOX.	HEXAGONAL M.4 INOX.	2	2	2			
	Q242020000	ARANDELA ABANICO A4 A.304	FAN SHAPED WASHER A.4	2	2	2			
	Q032021000	TORNILLO ALOMADO M4x10	CURVED SCREW M.4x10	2	2	2			
	Q412005000	REMACHE AVINOX Ø 3,2X6	AVINOX RIVET Ø 3,2X6	7	7	7			
11	T542817000	PANEL FRONTAL INFERIOR	LOWER FRONT PANEL	1	1	1			
12	T922801000	EMBELLECEDOR DUCHA	SHOWER TRIM	-	1	1			
13	T502805000	PANEL PORTAMANDOS 20-21 HEI	CONTROL PANEL 20-21 HEI	1	-	-			
13	T512806000	PANEL PORTAMANDOS 20-21 HEM	CONTROL PANEL 20-21 HEM	-	1	-			
13	T522802000	PANEL PORTAMANDOS 20-21 HEP	CONTROL PANEL 20-21 HEP	-	-	1			
S/Nº	T612806000	JUNTA PORTAMAND. HORZ 10/21	CONTROL HOLDER SEAL HORZ	1	1	1			
14	T492821000	GUIA CARRO COMP. IZDA. 202	COMPLE. LEFT TROLLEY GUIDE	1	1	1			
S/Nº	T492820000	GUIA CARRO COMP. DCHA. 202	COMPL. RIGHT TROLLEY GUIDE	1	1	1			
	Q412002000	REMACHE AVINOX Ø 4X10	AVINOX RIVET Ø 4X10	-	12	12			
15	T542821000	SOPORTE DUCHA	SHOWER SUPOR.	-	1	1			
	Q221342000	REMACHE EXAGONAL M5	HEXAGONAL RIVET M.5	-	4	4			
	Q232020000	ARANDELA A4	WASHER A.4	-	2	2			
	Q242020000	ARANDELA ABANICO A4	FAN SHAPED WASHER A.4	-	2	2			
	Q162020000	TUERCA EXAGONAL M4	HEXAGONAL NUT M4	-	2	2			
16	T452809000	DUCHA	SHOWER	-	1	1			
	Q232030000	ARANDELA A5	WASHER A.5	-	4	4			
	Q242030000	ARANDELA ABANICO A5 A.304	FAN SHAPED WASHER A.5	-	4	4			
	Q162030000	TUERCA EXAGONAL M5	HEXAGONAL NUT M5	-	4	4			
17	T512802000	BASE EXTERIOR 20/21	EXTERIOR BASE 20/21	1	1	1			
	Q221343000	REMACHE EXAGONAL M.6	HEXAGONAL RIVET M.6	35	35	35			
	Q221342000	REMACHE EXAGONAL M.5	HEXAGONAL RIVET M.5	4	4	4			
18	T330748000	TAPA CAJA CUBRE SIST LAVADO	COVER WASHING SYSTEM BOX	-	-	1			
	Q152004000	TORNILLO APLAST. M5X13 A 304	FLAT SCREW M.5x13	-	-	2			

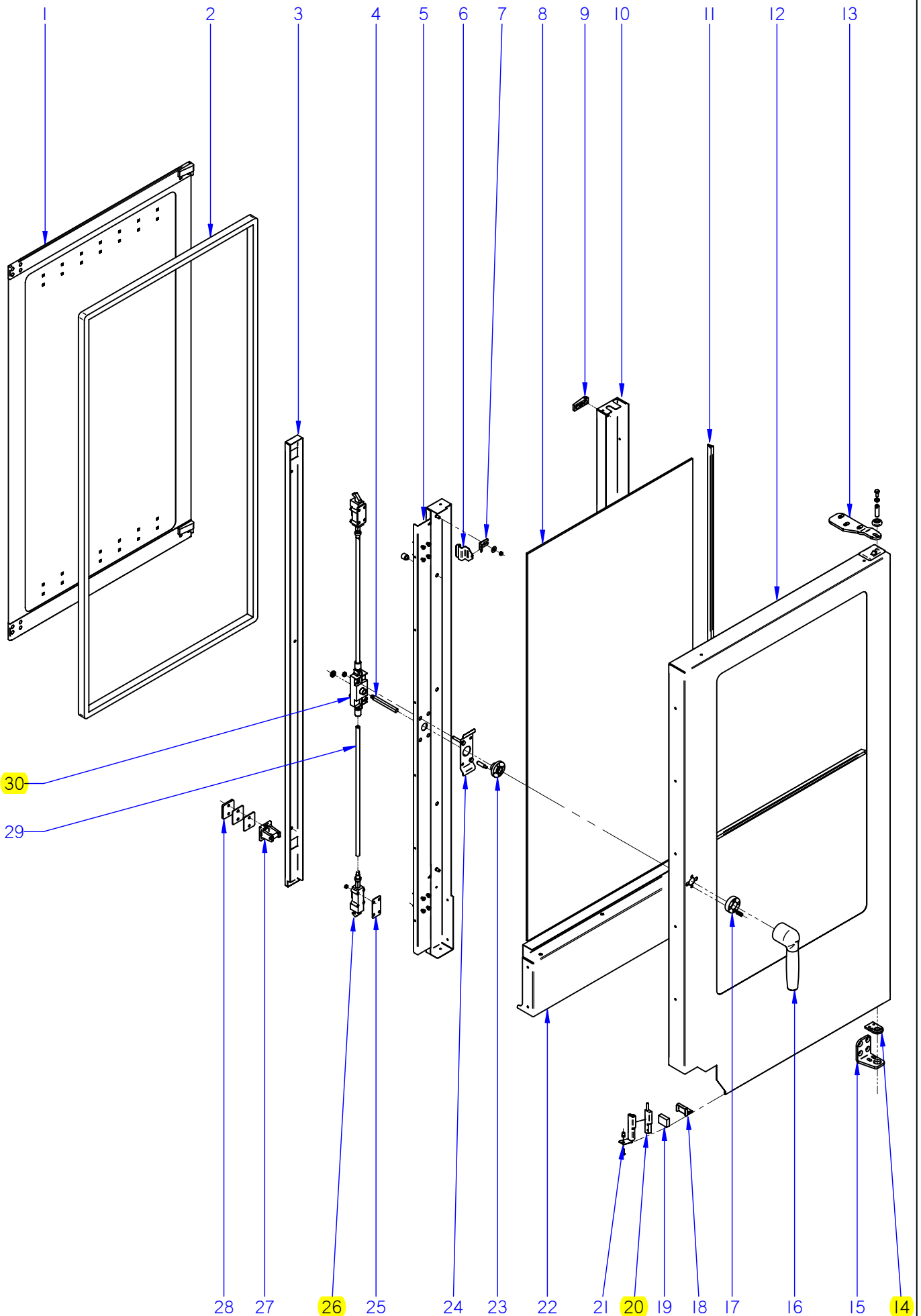

ITEM MARCADO EN COLOR = REPUESTO RECOMENDADO
 COLOURED ITEM = RECOMMENDED SPARE PART

N plano	Firma	Fecha	Aparato	PUERTA	Lamina	Fagor Industrial S.Coop. FAGOR
C-2439	<i>[Signature]</i>	2009-10	HORNOS COE / VE / VPE-202		2	Oñate

MOD.		HORNOS / OVEN		ZONA		PUERTA / DOOR				PLANO		C-2439	
ITEM	CODIGO	DENOMINACION	TEXTO	COE-202	VE-202	VPE-202						NOTAS	
	1100003146	KIT PUERTA 20/21 COMPL.	DOOR 20/21 KIT	1	1	1							
1	1100003117	KIT CRISTAL INTER. 20/21	20/21 INNER GLASS KIT	1	1	1							
2	T490500000	JUNTA DE PUERTA 20-21	DOOR JOINT	1	1	1							
3	T490503000	TAPA CIERRE PUERTA 20/21	DOOR CLOSING COVER 20/21	1	1	1							
	Q032021000	TORNILLO ALOMADO M4X10	CURVED SCREW M.4x10	2	2	2							
4	T490519000	EJE DE MANILLA PUERTA	LEVER SHAFT	1	1	1							
5	T490528000	CONTRAP MANILLA COMPL 20/21	COMPLETE HANDLE DOOR 202	1	1	1							
	Q412002000	REMACHE AVINOX Ø4X10	AVINOX RIVET Ø4X10	12	12	12							
	T300513000	TOPE CRISTAL INTERIOR10/21	INTERIOR GLASS BUFFER 10/2	8	8	8							
6	T300514000	PESTILLO	LATCH	2	2	2							
	R660605000	MUELLE TENSOR	LATCH TENSOR SPRING	2	2	2							
	Q302022000	ARANDELA 16X6X1.2 A.304	FLAT WASHER 16x6x1,2	2	2	2							
	Q242030000	ARANDELA ABANICO A5 A.304	FAN SHAPED WASHER A.5	2	2	2							
	Q162030000	TUERCA EXAGONAL M5	HEXAGONAL NUT M.5	2	2	2							
7	R670612000	BASE DE PESTILLO	LATCH BASE	2	2	2							
8	T490526000	CRISTAL EXTERIOR 20/21	EXTERNAL GLASS 20/21	1	1	1							
9	R670615000	BASE DE BISAGRA	HINGE BASE	2	2	2							
	Q042032000	TORNILLO AVELLANADO M5X15	COUNTERSUNK SCREW M.5x15	2	2	2							
10	T490527000	CONTRAPUERTA BISAGRA 20/21	INNER DOOR HINGE 20/21	1	1	1							
	Q412002000	REMACHE AVINOX Ø4X10	AVINOX RIVET Ø4X10	12	12	12							
11	3715200000	JUNTA CRISTAL	WINDOW SEAL	3	3	3							
12	T540502000	PUERTA 20/21	DOOR 20/21	1	1	1							
13	T300520500	BISAGRA SUPERIOR	UPPER HINGE	1	1	1							
	Q302025000	ARANDELA 8,4X20X1.5	WASHER 8,4X20X1.5	3	3	3							
	Q261050000	ARANDELA MUELLE A8	SPRING WASHER A8	3	3	3							
	Q012055000	TORNILLO EXAGONAL M8X30	HEXAGONAL BOLT M8X30	3	3	3							
S/Nº	R660534000	EJE SUPERIOR	UPPER SHAFT	1	1	1							
	R662807000	ARANDELA AMARRE	DOOR ANCHORING WASHER	1	1	1							
	Z850519000	RESORTE 06329	SPRING 06329	1	1	1							
14	R660549000	GUIA EJE INFERIOR FUNDIDO	LOWER SHAFT GUIDE	1	1	1							
	Q062040000	TORNILLO AVELLANADO M6X16	COUNTERSUNK SCREW M.6x16	4	4	4							

MOD.		HORNOS / OVEN		ZONA	PUERTA / DOOR			PLANO	C-2439
ITEM	CODIGO	DENOMINACION	TEXTO	COE-202	VE-202	VPE-202			NOTAS
15	T300521500	BISAGRA INFERIOR PLEGADA	LOWER FOLDER HINGE	1	1	1			
16	T130502000	MANILLA COMPLETA	HANDLE	1	1	1			
	Q032032000	TORNILLO ALOMADO M5X15	CURVED SCREW M5X15	2	2	2			
	Q271033000	ARANDELA DE SEGURIDAD Ø6	SAFETY WASHER Ø 6	1	1	1			
	Q132042000	VARILLA ROSCADA M6X15	THREADED ROD M.6x15	3	3	3			
17	T130514000	SOPORTE RESORTE	SPRING HOLDER	1	1	1			
	T130506000	RESORTE 34548	SPRING	2	2	2			
18	T300525000	SOPORTE IMAN	MAGNET HOLDER	1	1	1			
	Q222011000	REMACHE EXAGONAL M.5	HEXAGONAL RIVET M.5	1	1	1			
	Q032031000	TORNILLO ALOMADO M5X10	CURVED SCREW M5X10	1	1	1			
19	T300526000	IMAN	MAGNET	1	1	1			
20	Z100522000	INTERRUPTOR MAGNETICO	MAGNETIC SWITCH (DOOR)	1	1	1			
21	T302819000	SOPORTE MICRO PUERTA	DOOR MAGNETIC SWITCH HOLD	1	1	1			
	Q221342000	REMACHE EXAGONAL M.5	HEXAGONAL RIVET M.5	3	3	3			
22	T540506000	CHAPA AMARRE CONTRAP 10/21	DOOR REVERSE FASTE. PLATE	1	1	1			
S/Nº	T540503000	CHAPA JUNTA CONTRAPUERTA	DOOR REVERSE SEAL PLATE	1	1	1			
S/Nº	T540504000	JUNTA CIERRE INFERIOR 20/21	LOWER DOOR LOCK	1	1	1			
S/Nº	T540505000	SUPERIOR CIERRE PUERTA	UPPER DOOR LOCK	1	1	1			
23	T130515000	GUIA MANILLA	HANDLE GUIDE	1	1	1			
	T490518000	PITON ENGANCHE PUERTA	DOOR FASTENER SPIKE	2	2	2			
	Q032032000	TORNILLO ALOMADO M5x15	CURVED SCREW M.5x15	2	2	2			
24	T130511000	SUPLEMENTO SUJ. CERRADURA	LOCK FIXING SUPPLEMENT	1	1	1			
25	T080503000	SUPLEMENTO ELEMENTO CIERRE	CLOSING ELEMENT SUPPLEMEN	10	10	10			
26	T080504000	ELEMENTO CIERRE	CLOSING COMPONENT	2	2	2			
27	T110506000	ENGANCHE PUERTA	FASTENER	2	2	2			
	Q043145000	TORN. AVELLANADO 6X30 LATON	COUNTERSUNK SCREW 6X30	4	4	4			
28	T300519000	SUPLEMENTO ENGANCHE	FASTENER SUPPLEMENT	2	2	2			
S/Nº	R660538000	CALZO DE ENGANCHE	COUPLING CHOCK	2	2	2			
29	T490506000	TUBO ALARGADERA	ROD	2	2	2			

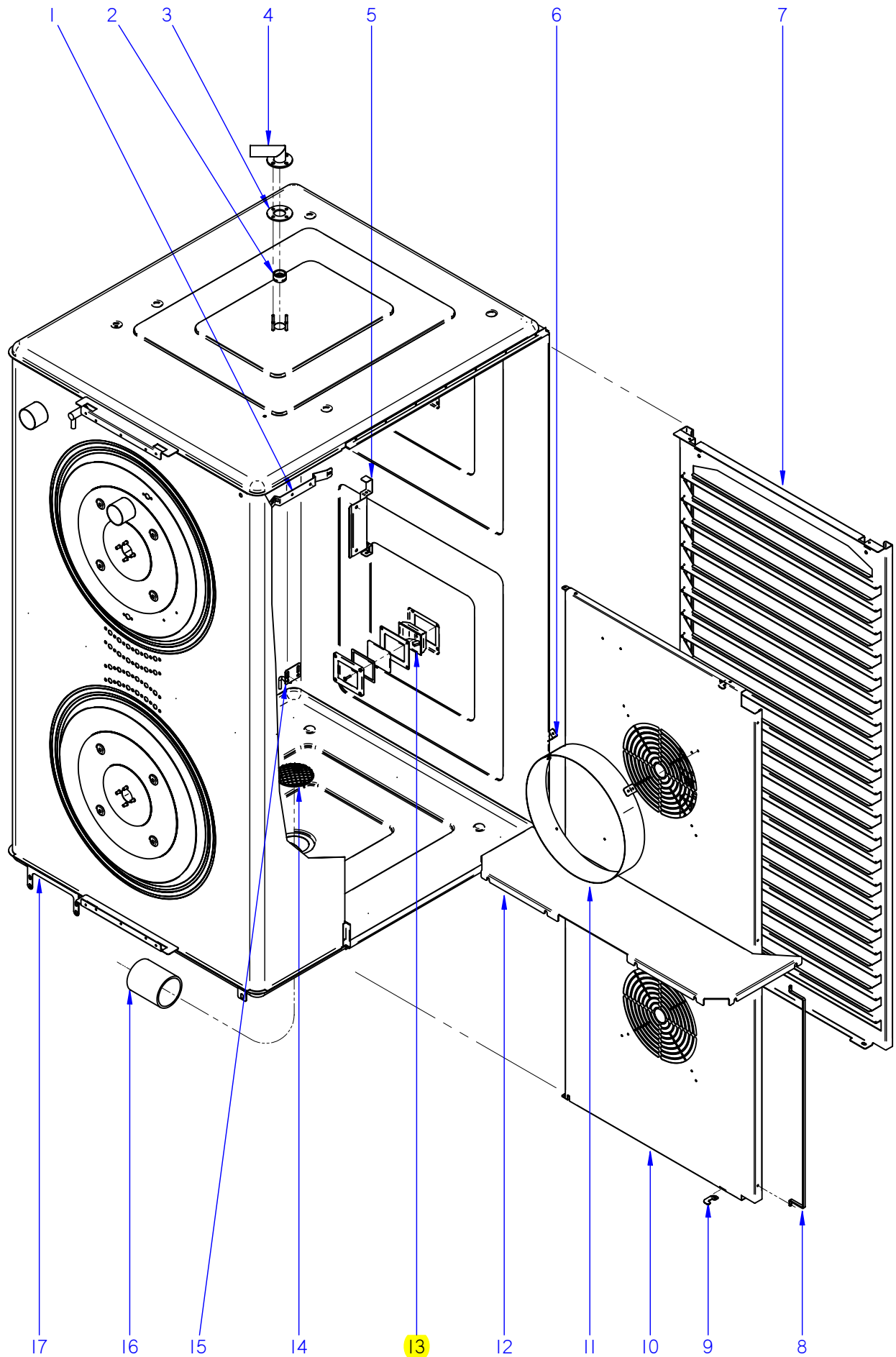

ITEM MARCADO EN COLOR = REPUESTO RECOMENDADO
 COLOURED ITEM = RECOMMENDED SPARE PART

N plano	Firma	Fecha	Aparato	MUEBLE INTERIOR	Lamina	Fagor Industrial S.Coop. FAGOR
C-2440	<i>[Signature]</i>	2009-10	HORNOS COE / VE / VPE-202		3	Oñate

MOD.		HORNOS / OVEN		ZONA	MUEBLE INTERIOR / INTERIOR OVEN			PLANO	C-2440	
ITEM	CODIGO	DENOMINACION	TEXTO	COE-202	VE-202	VPE-202				NOTAS
1	R662683000	SOPORTE BULBO	BULB SUPPORT	1	1	1				
	Q412002000	REMACHE AVINOX Ø4x10MM	TUBULAR RIVET 4x7,5	4	4	4				
2	T360712000	PUNTA DIFUSORA LAVADO	WASHING DISPENSER POINT	-	-	1				
3	T330744000	CHAPA AMARRE TUBO LAVADO	WASHING PIPE FASTENING PLATE	-	-	1				
4	T820702000	TUBO DIFUSOR LAVADO COMP.	COMPL. WASHING DISPENSER PIPE	-	-	1				
	Q232030000	ARANDELA A5	WASHER A.5	-	-	4				
	Q242030000	ARANDELA ABANICO A5 A.304	FAN SHAPED WASHER A.5	-	-	4				
	Q162030000	TUERCA EXAGONAL M5	HEXAGONAL NUT M.5	-	-	4				
5	T302644000	SOPORTE SONDA	PROBE SUPPORT	-	1	1				
	Q232030000	ARANDELA A5	WASHER A.5	-	2	2				
	Q242030000	ARANDELA ABANICO A5 A.304	FAN SHAPED WASHER A.5	-	2	2				
	Q162030000	TUERCA EXAGONAL M5	HEXAGONAL NUT M.5	-	2	2				
6	T302643000	FIJACIÓN SUPLEMENTO	FAN COVER SUPPLEM. BINDING	8	8	8				
	Q412002000	REMACHE AVINOX Ø4x10	RIVET AVINOX Ø4x10	23	23	23				
7	T442607000	PORTABANDEJAS 20/21	TRAY HOLDER 20/21	2	-	-				
S/Nº	T302688000	ENGANCHE PORTABANDEJAS	TRAY HOLDER FASTENER	2	-	-				
	Q222041000	REMACHE EXAGONAL M.4	HEXAGONAL RIVET M.4	2	-	-				
	Q232020000	ARANDELA A4	WASHER A.4	2	-	-				
	Q242020000	ARANDELA ABANICO A4	FAN SHAPED WASHER A.4	2	-	-				
	Q032021000	TORNILLO ALOMADO M4x10	CURVED SCREW M.4x10	2	-	-				
8	T302618000	PROTECCION INTERIOR	INTERIOR PROTECTION	2	2	2				
9	T302635000	ENGANCHE CUBREVENTILADOR	FAN COVER FASTENER	2	2	2				
	Q412002000	REMACHE AVINOX Ø4x10	RIVET AVINOX Ø4x10	16	16	16				
10	T452618000	CUBREVENTILADOR 20/21	FAN COVER 20/21	1	1	1				
11	T442604000	SUPLEMEN. CUBREVENTILADOR	FAN COVER SUPPLEMENT.	2	2	2				
12	T452605000	CHAPA REFUERZO CUBA 20/21	TUB REINFORCEMENT	1	1	1				
	Q232040000	ARANDELA A6	FLAT WASHER A.6	8	8	8				
	Q262040000	ARAND.GROW. A6 A.304	GROWER WASHER A.6	8	8	8				
	Q162040000	TUERCA EXAGONAL M6	HEXAGONAL NUT M.6	8	8	8				

N plano	Firma	Fecha	Aparato	TURERINA	Lamina	Fagor Industrial S. Coop. FAGOR Omate
C-2441		2009-10	HORNOS COE / VE / VPE-202		4	

ITEM MARCADO EN COLOR = REPUESTO RECOMENDADO
COLOURED ITEM = RECOMMENDED SPARE PART

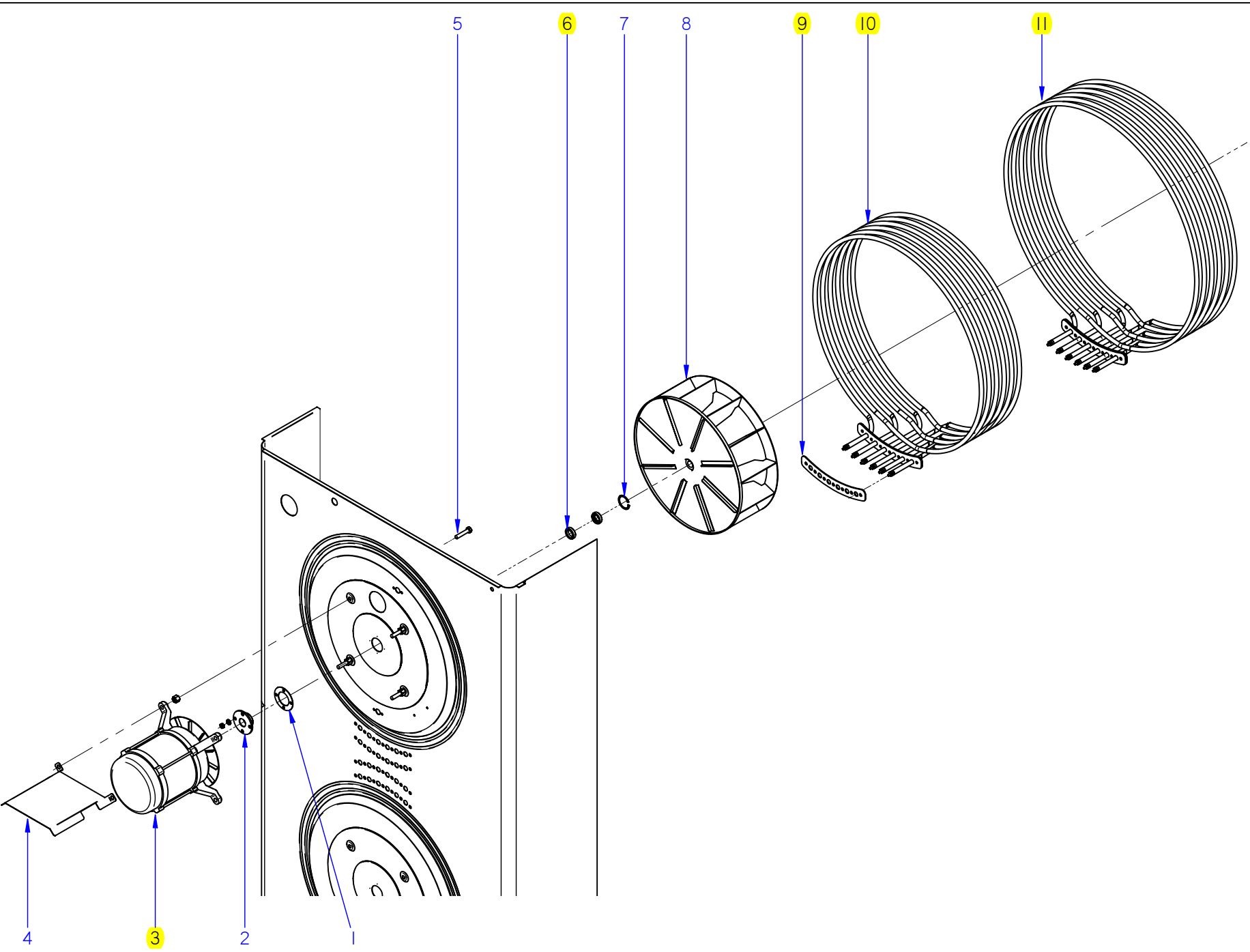

N plano
C-2442
Firma
(Signature)
Fecha
2009-10
Aparato
HORNOS COE / VE / VPE-202
CHIMENEA
Lamina
5
Fagor Industrial S. Coop.
Omate
FAGOR

ITEM MARCADO EN COLOR = REPUESTO RECOMENDADO
COLOURED ITEM = RECOMMENDED SPARE PART

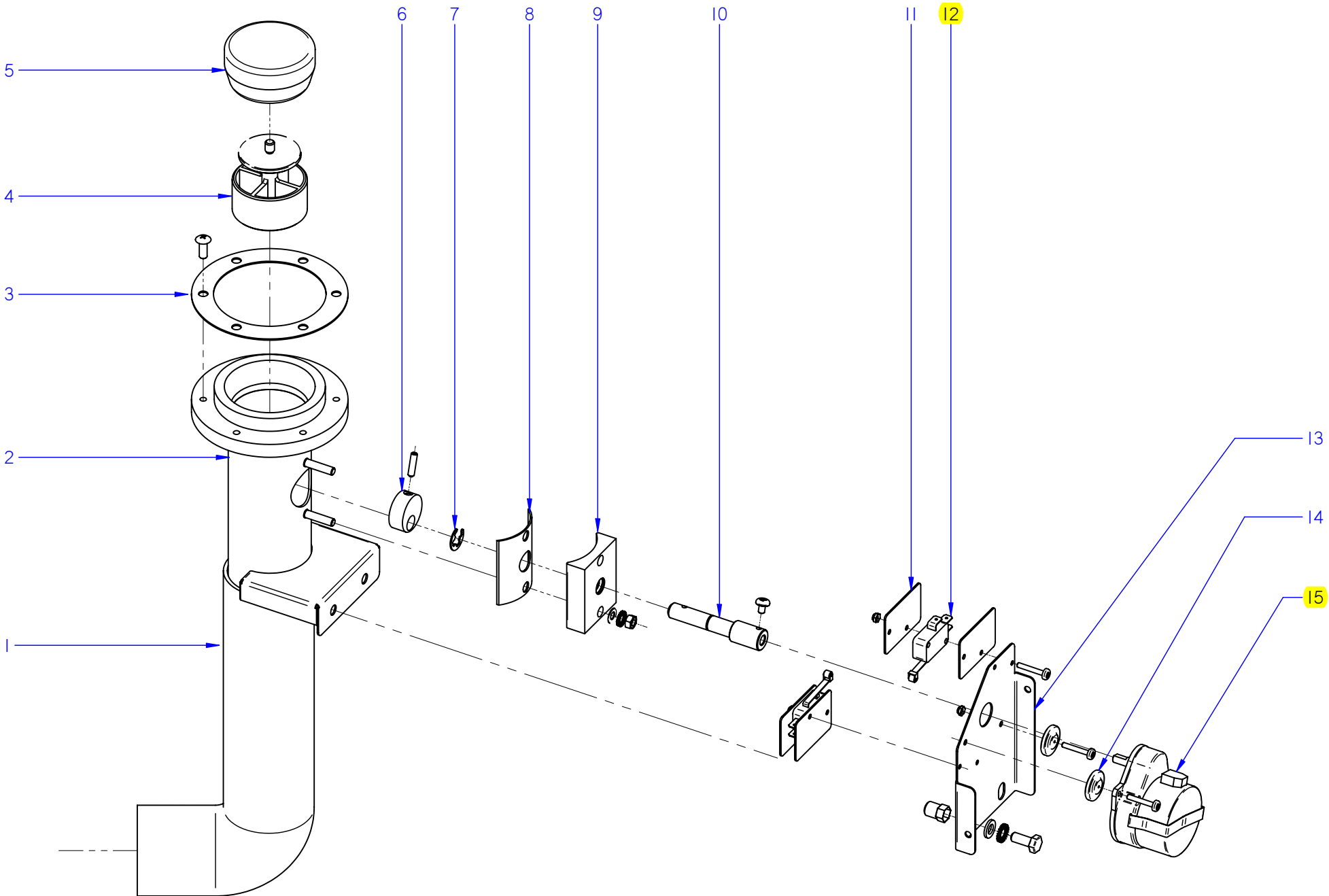

MOD.		HORNOS / OVEN		ZONA		CHIMENEA / FLUEPIPE			PLANO		C-2442
ITEM	CODIGO	DENOMINACION	TEXTO	COE-202	VE-202	VPE-202					NOTAS
1	T722608000	TUBO FLEXIBLE Ø53X360	FLEXIBLE TUBE Ø53X360	1	1	1					
	Q881307000	ABRAZADERA 40*60	CLAMP 40*60	2	2	2					
2	T815006000	CONJUNTO CHIMENEA	COMPLETE CHIMNEY	1	1	1					
	Q221343000	REMACHE EXAGONAL M.6	HEXAGONAL RIVET M.6	2	2	2					
3	T325057000	JUNTA BASE CHIMENEA	FLUEPIPE BASE SEAL	1	1	1					
	Q152004000	TORNIL. APLASTADO M5X13 A 304	FLAT SCREW M.5x13	6	6	6					
4	T815014000	GUIA RETENCION VAPORES	STEAM RETAINER GUIDE	1	1	1					
5	T325055000	RETENCION DE VAPORES	CLOSE CHIMNEY	1	1	1					
6	T325032000	LEVA EJE CHIMENEA	FLUEPIPE SHAFT CAM	1	1	1					
	Q132045000	VARILLA ROSCADA M4X16	THREADED ROD M4X16	1	1	1					
7	Q271006000	ARANDELA DE SEGURIDAD Ø8	SAFETY WASHER Ø8	1	1	1					
8	T325030000	JUNTA EJE CHIMENEA	FLUEPIPE SHAFT SEAL	1	1	1					
9	T325029000	GUIA EJE CHIMENEA	FLUEPIPE SHAFT GUIDE	1	1	1					
	Q232030000	ARANDELA A5	FLAT WASHER A.5	2	2	2					
	Q242030000	ARANDELA ABANICO A5 A.304	FAN SHAPED WASHER A.5	2	2	2					
	Q162030000	TUERCA EXAGONAL M5	HEXAGONAL NUT M.5	2	2	2					
10	T815010000	EJE CHIMENEA ELECTRICA	ELECTRIC FLUEPIPE SHAFT	1	1	1					
	Q151320000	TORNILLO ALOMADO M4X6 ZINC.	CURVED SCREW M4X6 ZINC.	1	1	1					
11	R010535000	PLACA SEPARADORA	SPACER PLATE	4	4	4					
	Q032013000	TORNILLO ALOMADO M3X20	CURVED SCREW M3X20	4	4	4					
	Q221350000	TUERCA AUTOBLOCANTE M3	SELF-LOCKING NUT M3	4	4	4					
12	R010534000	INTERRUPTOR PUERTA	DOOR SWITCH	2	2	2					
13	T815009000	ESCUA. AMARRE MOTOR CHIMEN.	FLUEPIPE MOTOR FASTENING B	1	1	1					
	Q232040000	ARANDELA A6	FLAT WASHER A.6	2	2	2					
	Q242040000	ARANDELA ABANICO A6 A.304	FAN SHAPED WASHER A.6	2	2	2					
	Q012042000	TORNILLO EXAGONAL M6X15 A304	HEXAGONAL SCREW M6X15	2	2	2					
14	Q308006000	ARANDELA DUBO Ø 4	WASHER DUBO Ø 4	3	3	3					
15	T323010000	MOTOR CHIMENEA	FLUEPIPE MOTOR	1	1	1					

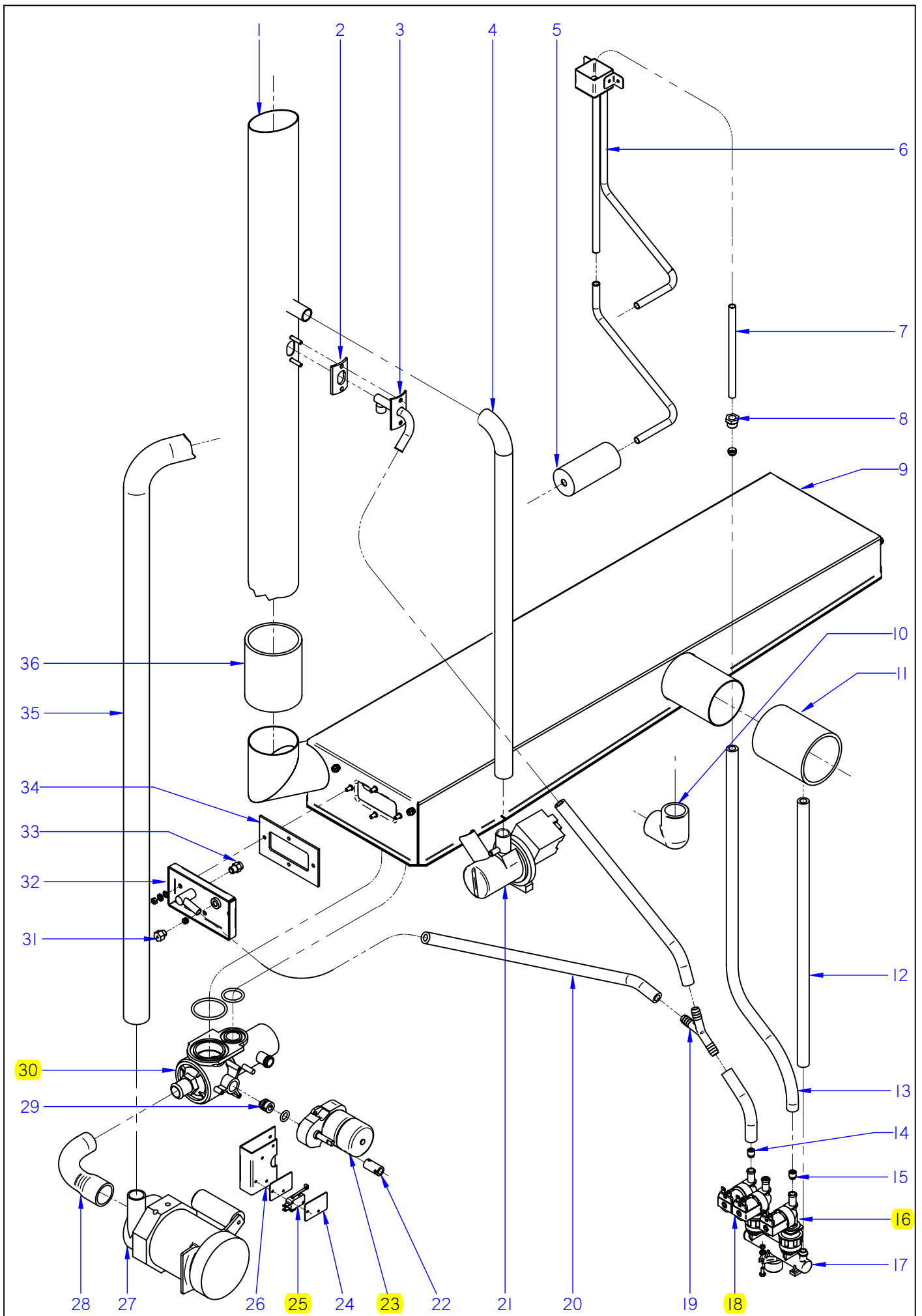

ITEM MARCADO EN COLOR = REPUESTO RECOMENDADO
 COLOURED ITEM = RECOMMENDED SPARE PART

N plano	Firma	Fecha	Aparato	CIRCUITO DE AGUA	Lamina	Fagor Industrial S.Coop. FAGOR
C-2443	<i>(Signature)</i>	2009-10	HORNOS COE / VE / VPE-202		6	Oñate

MOD.		HORNOS / OVEN		ZONA		CONDUCCIONES DE AGUA / WATER PIPES		PLANO		C-2443	
ITEM	CODIGO	DENOMINACION	TEXTO	COE-202	VE-202	VPE-202					NOTAS
1	T445005000	CHIMENEA COMPLETA HEI-20/21	COMPLET FLUEPIPE HEI-20/21	1	-	-					
1	T455006000	CHIMENEA COMPLETA HEM-20/21	COMPLET FLUEPIPE HEM-20/21	-	1	1					
S/Nº	T115086000	TOBERA 1/8	NOZZLE 1/8	1	1	1					
2	R725159000	JUNTA TUBO INYECTOR	INJECTOR PIPE SEAL	1	1	1					
3	T115112000	CONDUCC. VAHOS COMPLETO	COMPLETE VAPOUR DUCT	1	1	1					
4	3715900000	TUBO SILICONA Tº Ø 26*18	HIGH SILICON PIPE Tº Ø 26*18	-	1	1					
	Q901311000	ABRAZADERA ELASTICA 26,7*28,1	ELAST. CLAMP 26,7*28,1	-	2	2					
5	R665025000	DISTRIBUIDOR INYECTOR	INJECTOR DISTRIBUTOR	1	-	-					
6	T445000000	INYECTOR COMPLETO HEI 20/21	COMPLETE INJECTOR HEI 2021	1	-	-					
7	T355001000	TUBO INYECTOR	INJECTOR PIPE	1	-	-					
7	R665024000	TUBO INYECTOR	INJECTOR PIPE	-	1	1					
8	R695003000	MANGUITO CIERRE	CLOSING SLEEVE	1	1	1					
	R695004000	BICONO	BICONE	1	1	1					
9	T515005000	CAJA DESAGÜE LAVADO 20/21	COM. DRAINAGE BOX 20/21	1	1	-					
9	T525001000	CONJUNTO CAJA LAVADO 20/21	COMPLETE WASH BOX 20/21	-	-	1					
10	T505011000	CONDUCCION DESAGUE	DRAINAGE DUCT	1	1	-					
11	T455029000	TUBO EMPALME GENERADOR	GENERATOR CONNECTI. PIPE	1	1	1					
	Q901313000	ABRAZADERA ELASTICA 62-66	CLAMP 62-66	2	2	2					
12	3676900000	T. GOMA NEGRA Ø17*10 INYECT.	BLACK RUBBER PIPE Ø17*10	-	1	1					
	Q881302000	ABRAZADERA 12*20	CLAMP 12-20	-	2	2					
13	3676900000	T. GOMA NEGRA Ø17*10 INYECT.	BLACK RUBBER PIPE Ø17*10	1	1	1					
	Q881302000	ABRAZADERA 12*20	CLAMP 12-20	2	2	2					
14	P443042000	REGULADOR 3 L. VERDE 254,023	REGULATOR 3 L. GREEN	1	1	1					
15	P305013000	REGULADOR 1L. AMA 255.005	REGULATOR 1L. AMA 255.005	1	1	1					
16	Z701135000	ELECTROVALVUL. SIMPLE 255.208	SIMPLE SOLENOID VALVE	-	1	1					
17	T325063000	ENTRADA DE AGUA COMPLETA	COMPLETE WATER INLET	-	1	1					
	Q307031000	JUNTA TUBO 14X24X3	JOINT 14X24X3	-	2	2					
	Q012021000	TORNILLO EXAGONAL M4x10 A304	HEXAGONAL BOLT M4x10 A304	-	2	2					
	Q242010000	ARANDELA ABANICO A3 A.304	FAN SHAPED WASHER A.3	-	2	2					
	Q162020000	TUERCA EXAGONAL M4	HEXAGONAL NUT M.4º	-	2	2					
18	P255001000	ELECTROVALVULA DOBLE	DOUBLE SOLENOID VALVE	1	1	1					

MOD.		HORNOS / OVEN		ZONA		CONDUCCIONES DE AGUA / WATER PIPES		PLANO		C-2443	
ITEM	CODIGO	DENOMINACION	TEXTO	COE-202	VE-202	VPE-202					NOTAS
19	Z201106000	RACORD EN Y	Y-CONNECTION	1	1	1					
20	3676900000	T. GOMA NEGRA Ø17*10 INYECT.	BLACK RUBBER PIPE Ø17*10	2	2	2					
	Q881302000	ABRAZADERA 12*20	CLAMP 12-20	4	4	4					
21	Z220901000	BOMBA DESAGÜE 30W	DRAINAGE PUMP 30W	-	1	1					
22	T330733000	CASQUILLO MOTOR MICRO	MICRO MOTOR BUSHING	-	-	1					
	Q151320000	TORNILLO ALOMADO M4X6 H.ZIN.	CURVED SCREW M4X6 H.ZIN.	-	-	2					
	Q371026000	MANGUITO SUJEC. 4X14 DIN1481	HOSE FASTENING 4X14 DIN1481	-	-	1					
	Q052032000	TORNILLO ALLEN M.5x15(+)	ALLEN HEAD SCREW M.5x15(+)	-	-	2					
23	T330711000	MOTOR VALVULA	VALVE MOTOR	-	-	1					
	Q042022000	TORNILLO AVELLANADO M4X15	COUNTERSUNK SCREW M.4x15	-	-	2					
24	R010535000	PLACA SEPARADORA	SPACER PLATE	-	-	4					
	Q032013000	TORNILLO ALOMADO M3X20	CURVED SCREW M3X20	-	-	7					
	Q221350000	TUERCA AUTOBLOCANTE M3	SELF-LOCKING NUT M3	-	-	4					
25	R010534000	INTERRUPTOR PUERTA	DOOR SWITCH	-	-	2					
26	T330713000	CHAPA SUJECCION MICROS	FASTENING PLATE MICROS	-	-	1					
27	T360715000	MOTOBOMBA 5213E2450 FIR 50Hz	MOTOR-PUMP 5213E2450 FIR	-	-	1					
	Q232040000	ARANDELA A6	WASHER A.6	-	-	2					
	Q242040000	ARANDELA ABANICO A6 A.304	FAN SHAPED WASHER A.6	-	-	2					
	Q012043000	TORNILLO EXAGONAL M6X20	HEXAGONAL SCREW M6X20	-	-	2					
28	T330731000	GOMA VALVULA BOMBA	PUMP VALVE RUBBER	-	-	1					
	Q881304000	ABRAZADERA 20-32	CLAMP 20-32	-	-	1					
	Q881305000	ABRAZADERA 25-40	CLAMP 25-40	-	-	1					
29	T330707000	PUNTA ACOPLE MOTOR A VALV.	CONN. POINT MOTOR TO VAL.	-	-	1					
	Q307084000	JUNTA TORICA Ø18X3.5	O-RING Ø18X3.5	-	-	1					
30	T330723000	CUERPO VALVULA COMPLETO	COMPLETE VALVE BODY	-	-	1					
	Q307080000	JUNTA TORICA Ø52X3,5	O-RING Ø52X3.5	-	-	1					
	Q307079000	JUNTA TORICA Ø33x3,5	O-RING Ø33x3.5	-	-	1					
31	R662629000	RACORD CIERRE SONDA	PROBE CLOSING ADAPTOR	1	1	1					
	R662652000	BICONO CIERRE SONDA	PROBE CLOSING BICONE	1	1	1					
32	T325075000	FIJACION SONDA CONDENSADOR	COMPLET. PROBE FASTENING	1	1	1					
33	T115086000	TOBERA 1/8	NOZZLE 1/8	1	1	1					

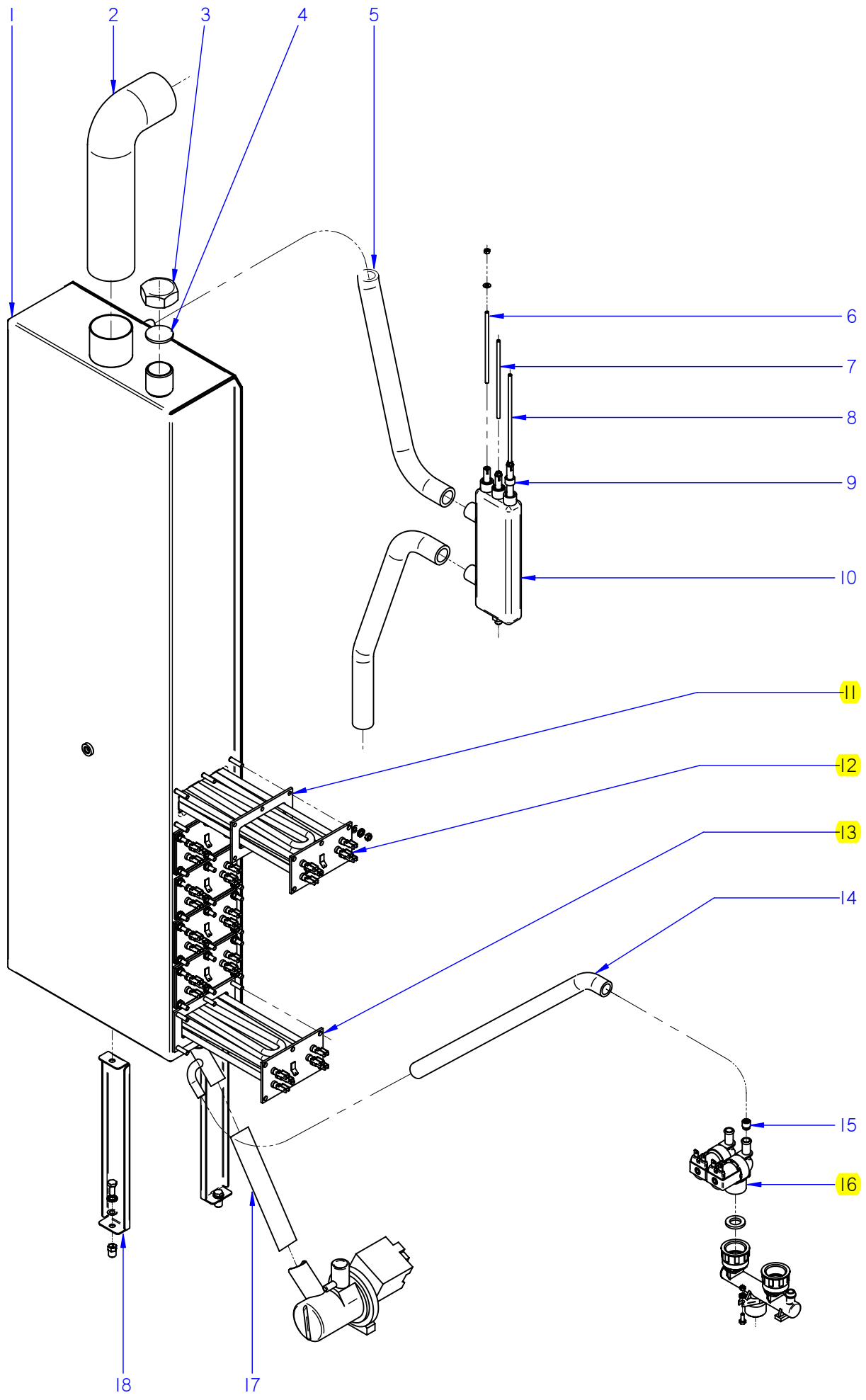

ITEM MARCADO EN COLOR = REPUESTO RECOMENDADO
 COLOURED ITEM = RECOMMENDED SPARE PART

N plano	Firma	Fecha	Aparato	CIRCUITO DE VAPOR	Lamina	Fagor Industrial S.Coop. FAGOR
C-2444	<i>[Signature]</i>	2009-10	HORNOS VE-202 / VPE-202		7	Oñate

MOD.		HORNOS / OVEN		ZONA	CIRCUITO DE VAPOR / STEAM CIRCUIT				PLANO	C-2444
ITEM	CODIGO	DENOMINACION	TEXTO	VE-202	VPE-202					NOTAS
1	1100003147	KIT GENERADOR DE VAPOR 20/21	STEAM GENERATOR KIT 20/21	1	1					
2	T722608000	TUBO FLEXIBLE Ø53X360	FLEXIBLE TUBE Ø53X360	1	1					
	Q881307000	ABRAZADERA 40*60	CLAMP 40*60	2	2					
3	R015010000	TUERCA TAPON 1"	PLUG NUT 1"	1	1					
4	R015011000	ARANDELA Ø32	WASHER Ø32	1	1					
5	3715900000	TUBO SILICONA T° Ø 26*18	HIGH SILICON PIPE T° Ø 26*18	2	2					
	Q901311000	ABRAZADERA ELASTICA 26,7*28,1	ELAST. CLAMP 26,7*28,1	4	4					
6	R345060000	ELECTRODO ALTO	HIGH LEVEL ELECTRODE	1	1					
7	R345063000	ELECTRODO BAJO	LOW LEVEL ELECTRODE	1	1					
8	R345064000	ELECTRODO DE MASA	EARTH ELECTRODE	1	1					
	Q232020000	ARANDELA A4	FLAT WASHER A.4	3	3					
	Q162020000	TUERCA EXAGONAL M4	HEXAGONAL NUT M.4	3	3					
9	R345069000	GUIA AISLANTE	INSULATION GUIDE	3	3					
10	T325077000	BOTE DE NIVELES	LEVELS VESSEL	1	1					
	Q228051000	TUERCA EXAGONAL M8 PLASTIC	HEXAGONAL NUT M8 PLASTIC	1	1					
11	T323007000	JUNTA CIERRE RESISTENCIAS	RESISTOR SEAL	6	6					
	Q232030000	ARANDELA A5	WASHER A.5	36	36					
	Q242030000	ARANDELA ABANICO A5 A.304	FAN SHAPED WASHER A.5	36	36					
	Q163030000	TUERCA EXAGONAL M5 LATON	HEXAGONAL NUT M5	36	36					
12	T323006000	RESISTENCIA 3x3000W 230V	RESISTOR 3x3000W 230V	1	1					
13	T323038000	RESISTENCIA 3x3000W 230V	RESISTOR 3x3000W 230V	5	5					
14	3676900000	T. GOMA NEGRA Ø17*10	BLACK RUBBER PIPE Ø17*10	1	1					
	Q881302000	ABRAZADERA 12*20	CLAMP 12-20	2	2					
15	P443042000	REGULADOR 3 L. VERDE 254,023	REGULATOR 3 L. GREEN	1	1					
16	P255001000	ELECTROVALVULA DOBLE	DOUBLE SOLENOID VALVE	1	1					
17	3715900000	TUBO SILICONA T° Ø 26*18	HIGH SILICON PIPE T° Ø 26*18	1	1					
	Q901311000	ABRAZADERA ELASTICA 26,7*28,1	ELAST. CLAMP 26,7*28,1	2	2					

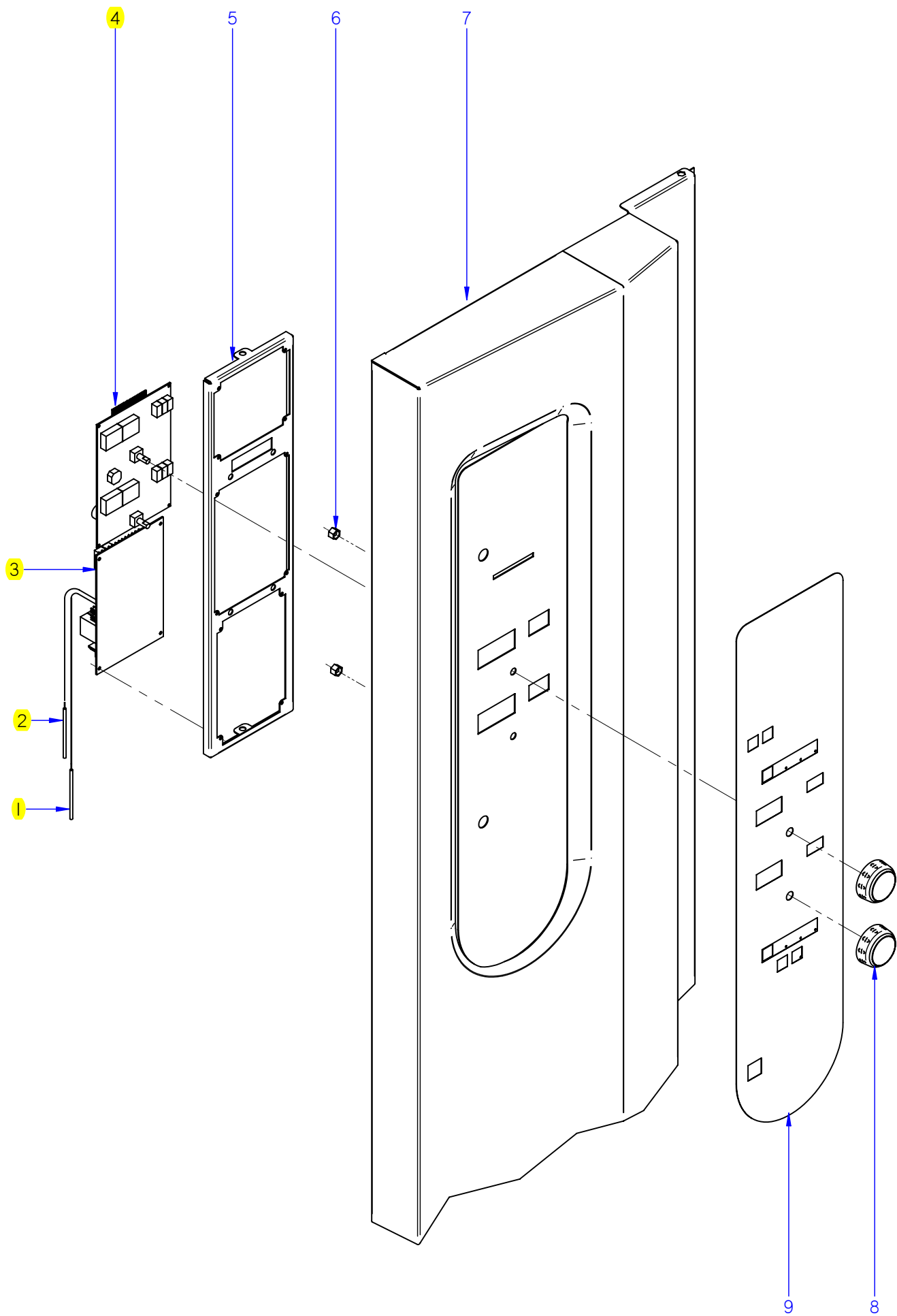

ITEM MARCADO EN COLOR = REPUESTO RECOMENDADO
 COLOURED ITEM = RECOMMENDED SPARE PART

N plano	Firma	Fecha	Aparato	CONJUNTO ELECTRICO PORTAMANDOS	Lamina	Fagor Industrial S.Coop. FAGOR
C-2445	<i>[Signature]</i>	2009-10	HORNOS COE-202		8	Oñate

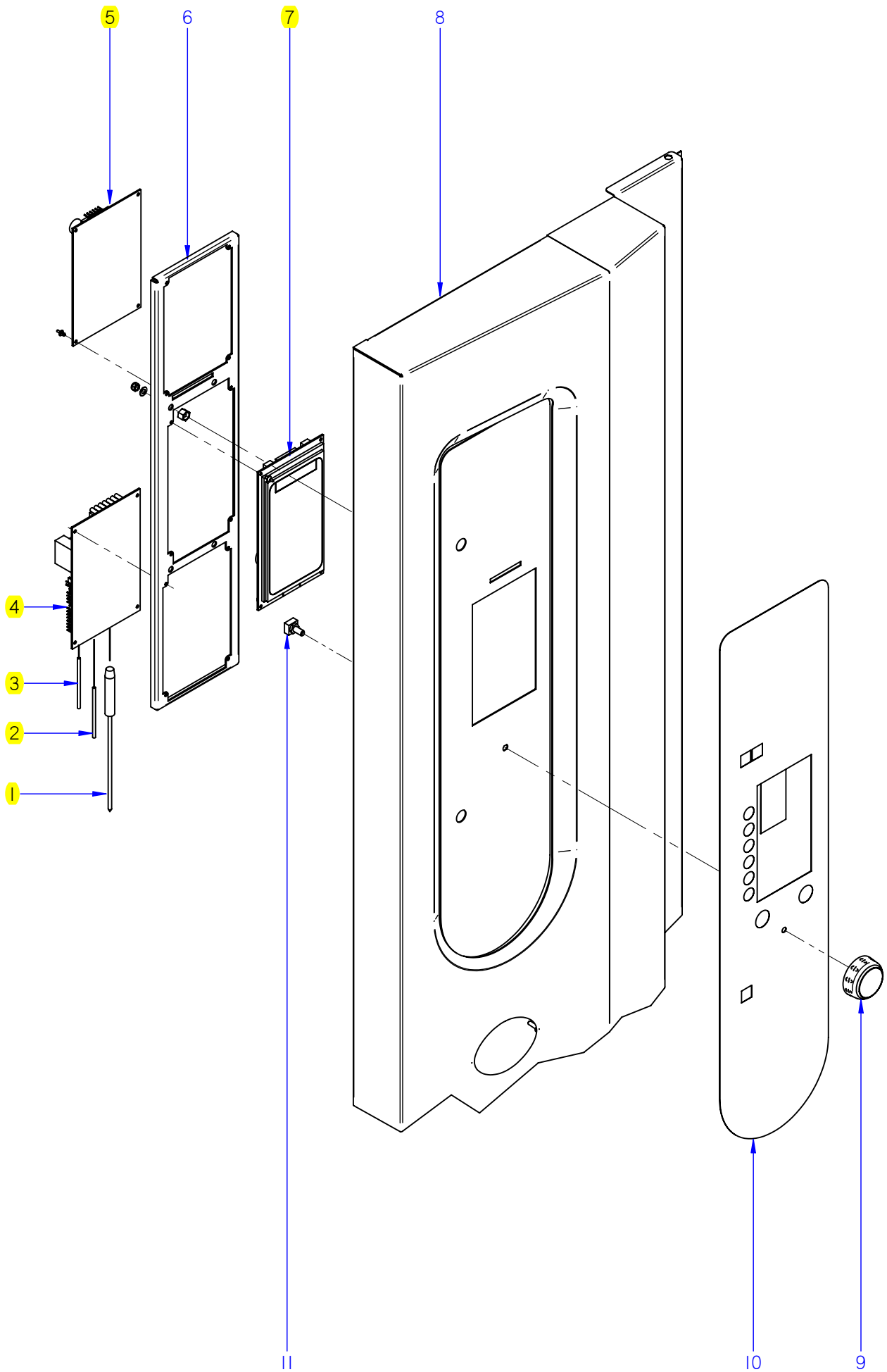

ITEM MARCADO EN COLOR = REPUESTO RECOMENDADO
 COLOURED ITEM = RECOMMENDED SPARE PART

N plano	Firma	Fecha	Aparato	CONJUNTO ELECTRICO PORTAMANDOS	Lamina	Fagor Industrial S.Coop. FAGOR
C-2446	<i>[Signature]</i>	2009-10	HORNOS VE-202		9	Oñate

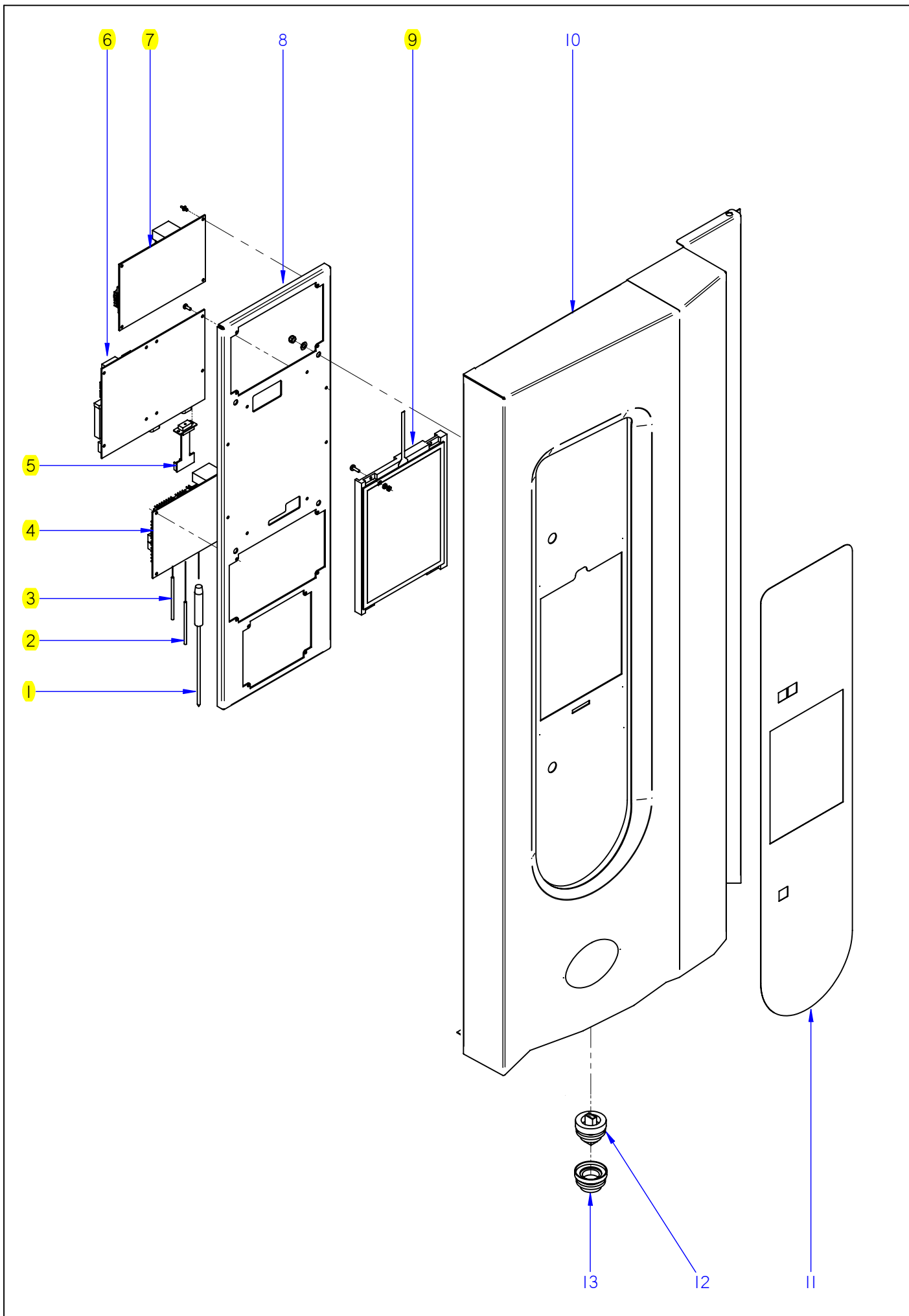

ITEM MARCADO EN COLOR = REPUESTO RECOMENDADO
 COLOURED ITEM = RECOMMENDED SPARE PART

N plano	Firma	Fecha	Aparato	CONJUNTO ELECTRICO PORTAMANDOS	Lamina	Fagor Industrial S.Coop. FAGOR
C-2447	<i>[Signature]</i>	2009-10	HORNOS VPE-202		10	Oñate

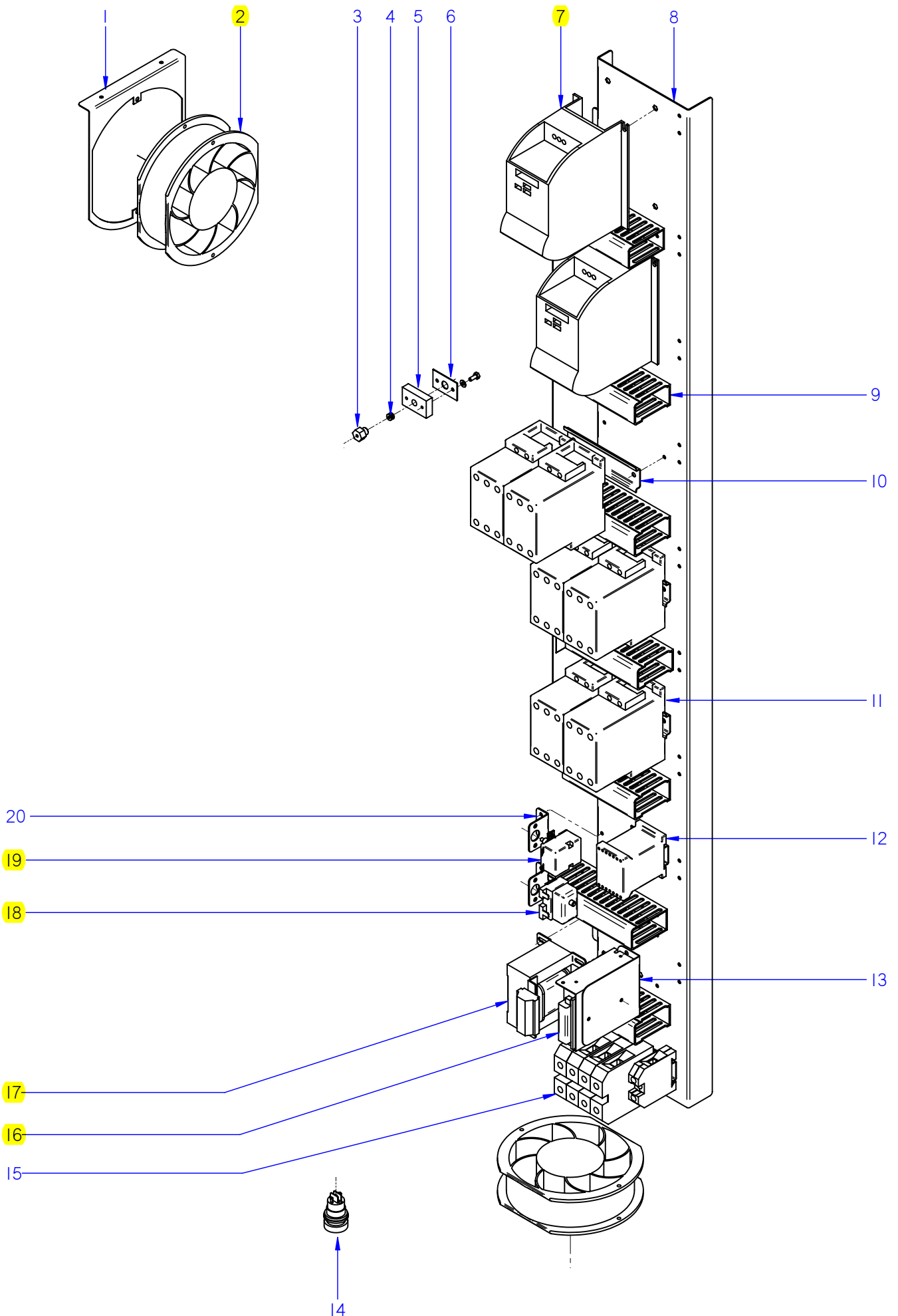

ITEM MARCADO EN COLOR = REPUESTO RECOMENDADO
 COLOURED ITEM = RECOMMENDED SPARE PART

N plano	Firma	Fecha	Aparato	CUADRO ELECTRICO	Lamina	Fagor Industrial S.Coop. FAGOR
C-2448	<i>[Signature]</i>	2009-10	HORNOS COE / VE / VPE-202		11	Oñate

MOD.		HORNOS / OVEN		ZONA		CUADRO ELECTRICO / ELECTRIC PANEL		PLANO		C-2448	
ITEM	CODIGO	DENOMINACION	TEXTO	COE-202	VE-202	VPE-202					NOTAS
1	T513001000	CHAPA AMARRE VENTILADOR	FAN HOLDER PLATE	2	2	2					
	Q412002000	REMACHE AVINOX Ø4x10MM	TUBULAR RIVET 4x7,5	2	2	2					
	Q031322000	TORNILLO ALOMADO M4x15	CURVED SCREW M.4x15	4	4	4					
	Q232020000	ARANDELA A4	WASHER A.4	4	4	4					
	Q242020000	ARANDELA ABANICO A4 A.304	FAN SHAPED WASHER A.4	4	4	4					
	Q162020000	TUERCA EXAGONAL M4	HEXAGONAL NUT M.4	4	4	4					
2	T453005000	VENTILADOR 230V.20/21	FAN 230V 20/21	2	2	2					
3	R662629000	RACORD CIERRE SONDA	PROBE CLOSING ADAPTOR	2	2	2					
S/Nº	R662662000	JUNTA CIERRE BULBO LIMITADOR	BULB LIMITER CLOSING SEAL	1	1	1					
4	R662652000	BICONO CIERRE SONDA	PROBE CLOSING BICONE	1	1	1					
5	T112625000	BASE CIERRE SONDA	FIXING CORE PROBE	2	2	2					
6	R692812000	JUNTA PASAMUROS SIMPLE	SIMPLE FEEDTHROUGH SEAL	2	2	2					
	Q232020000	ARANDELA A4	WASHER A.5	4	4	4					
	Q012021000	TORNILLO EXAGONAL M4X10	HEXAGONAL SCREW M.4X10	4	4	4					
7	T323037000	VARIADOR FRECUENCIA SIE 0,37	FREQUENCY VARIATOR SIE 0.37	2	2	2					
	Q232020000	ARANDELA A4	WASHER A.5	4	4	4					
	Q242020000	ARANDELA ABANICO A4 A.304	FAN SHAPED WASHER A.4	4	4	4					
	Q032021000	TORNILLO ALOMADO M4X10	CURVED SCREW M.4x10	4	4	4					
8	T513007000	CHAPA CUADRO ELEC 20/21	SQUARE PLATE ELEC 20/21	1	1	1					
	Q221341000	REMACHE EXAGONAL M4	HEXAGONAL RIVET M.4	8	8	8					
	Q221342000	REMACHE EXAGONAL M5	HEXAGONAL RIVET M.5	3	3	3					
	Q232030000	ARANDELA A5	WASHER A.5	4	4	4					
	Q242030000	ARANDELA ABANICO A5 A.304	FAN SHAPED WASHER A.5	4	4	4					
	Q012032000	TORNILLO EXAGONAL M5x15A304	HEXAGONAL SCREW M.5x15	4	4	4					
9	3715520000	CANALETA UNEX 60.30.77 / 0.12	PIPING UNEX 60.30.77 / 0.12	8	7	8					
	Q412002000	REMACHE AVINOX Ø4x10MM	TUBULAR RIVET 4x7,5	28	32	34					
10	R663055000	GUIA CONTACTOR L-120	CONTACTOR GUIDE L=120	3	4	4					
10	Z123018000	GUIA CONTACTOR L-55	CONTACTOR GUIDE L=55	1	1	1					
11	T453016000	CONTACTOR 50A 3RT1034-1AL20	50A 3RT1034-1AL20 CONTACT.	4	=	6					
12	Z203050000	CONTAC. SIRIUS 3R 230V.50-60	SIRIUS 3R 230V.50-60 CONTAC.	1	7	1					

MOD.		HORNOS / OVEN		ZONA		VARIOS / MISCELLANEOUS			PLANO	
ITEM	CODIGO	DENOMINACION	TEXTO	COE-202	VE-202	VPE-202				
	T906501000	MANUAL DE INSTRUCCION. COE	INSTRUCTIO. BROCHURE COE	1	-	-				
	T916501000	MANUAL DE INSTRUCC. VE	INSTRUC. BROCHURE VE	-	1	-				
	T926501000	MANUAL DE INSTRUCC. VPE	INSTRUC. BROCHURE VPE SPA	-	-	1				
	T326507000	MANUAL DE INSTRUCC. VPE ING.	INSTRUC. BROCHURE VPE ENG	1	1	1				
	T326506000	MANUAL DE INSTRUCC. VPE FRA.	INSTRUC. BROCHURE VPE FRE	1	1	1				
	T326501000	MANUAL DE INSTRUCC. VPE ALE.	INSTRUC. BROCHURE VPE GER	1	1	1				
	T326508000	MANUAL DE INSTRUCC. VPE ITA.	INSTRUC. BROCHURE VPE ITA	1	1	1				
	T503002000	ESQUE. TEORICO CONCEP E2021	THE. DIAGRAM VCONCEP E2021	1	-	-				
	T513002000	ESQUEMA TEORICO VISUAL E202	THEOR. DIAGRAM VISUAL E202	-	1	-				PLANO HC-80805
	T523001000	ESQ. TEORICO VISUAL PLUS E202	THEOR. DIAGRAM VISUAL PLU	-	-	1				
	T503003000	PLANO MONTAJE CONCEP E2021	ASSEMBLY PLAN CONCEP E2021	1	-	-				PLANO HC-81479
	T513003000	PLANO MONTAJE VISUAL E202	ASSEMBLY PLAN VISUAL E202	-	1	-				PLANO HC-81496
	T523002000	PLANO MONTAJE VIS. PLUS E202	ASSEMBLY PLAN VIS. PLUS E202	-	-	1				PLANO HC-81495
	T503004000	INSTAL. ELECTRICA CONCEP E2021	ELEC. INSTALL. CONCEP E2021	1	-	-				
	T513006000	INSTAL. ELECTRICA VISUAL E2021	ELEC. INSTALL. VISUAL E 2021	-	1	1				
	T913006000	CAB CIRCUIT PORTAMANDOS VIS.	VIS. CONTROL HOLDER CIRCUIT	-	1	-				
	T503005000	CABLEADO FUERZA CONCEP E2021	POWER WIRE. CONCEP E2021	1	-	-				
	T513004000	CABLEADO FUERZA VISUAL E2021	POWER WIRE. VISUAL E2021	-	1	1				
	T503007000	CABLE. VARIADOR CONCEP E2021	VARIATOR WIRING CON. E2021	1	1	1				
	T503006000	CABLEADO RESIST. CONCEP E2021	RESISTOR WIRING CON. E2021	1	-	-				
	T513005000	CABLEADO RESIST. VISUAL E2021	RESISTOR WIRING VISUAL E202	-	1	1				
	T903006000	CABLEADO COMUNICACIÓN BMF	COMMUNICATION WIRING BMF	1	2	2				
	T493010000	CABLEADO LUZ INTERIOR 20/21	INTERIOR LIGHT WIRING 20/21	1	1	1				
	T333009000	CABLEADO LAVADO HEP	WASH WIRING HEP	-	-	1				
	T553006000	CABLEADO FUENTE ALIMENTAC.	POWER SUPPLY WIRING	-	-	1				
	T523003000	CABL ADAPT TFT VISUAL+ x/21	ADAPT. WIRING TFT VISUAL+x/21	-	-	1				
	T723008000	CABLE USB VISUAL PLUS	VISUAL PLUS USB CABLE	-	-	1				

COE 202

3N-50/60Hz 380/415V

3-50/60Hz 220V

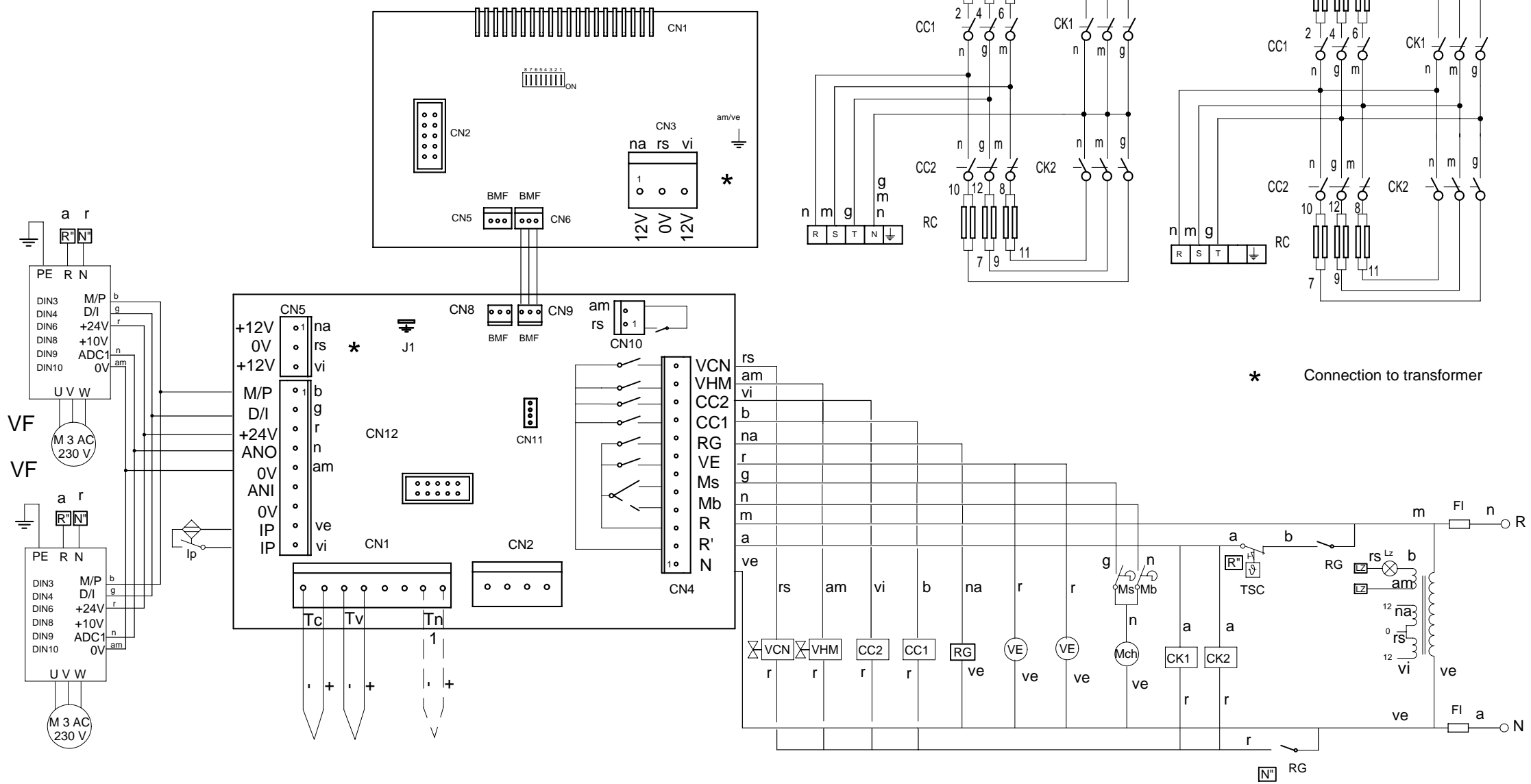

* Connection to transformer

T503002000

VE 202

3N-50/60Hz 380/415V

3-50/60Hz 220V

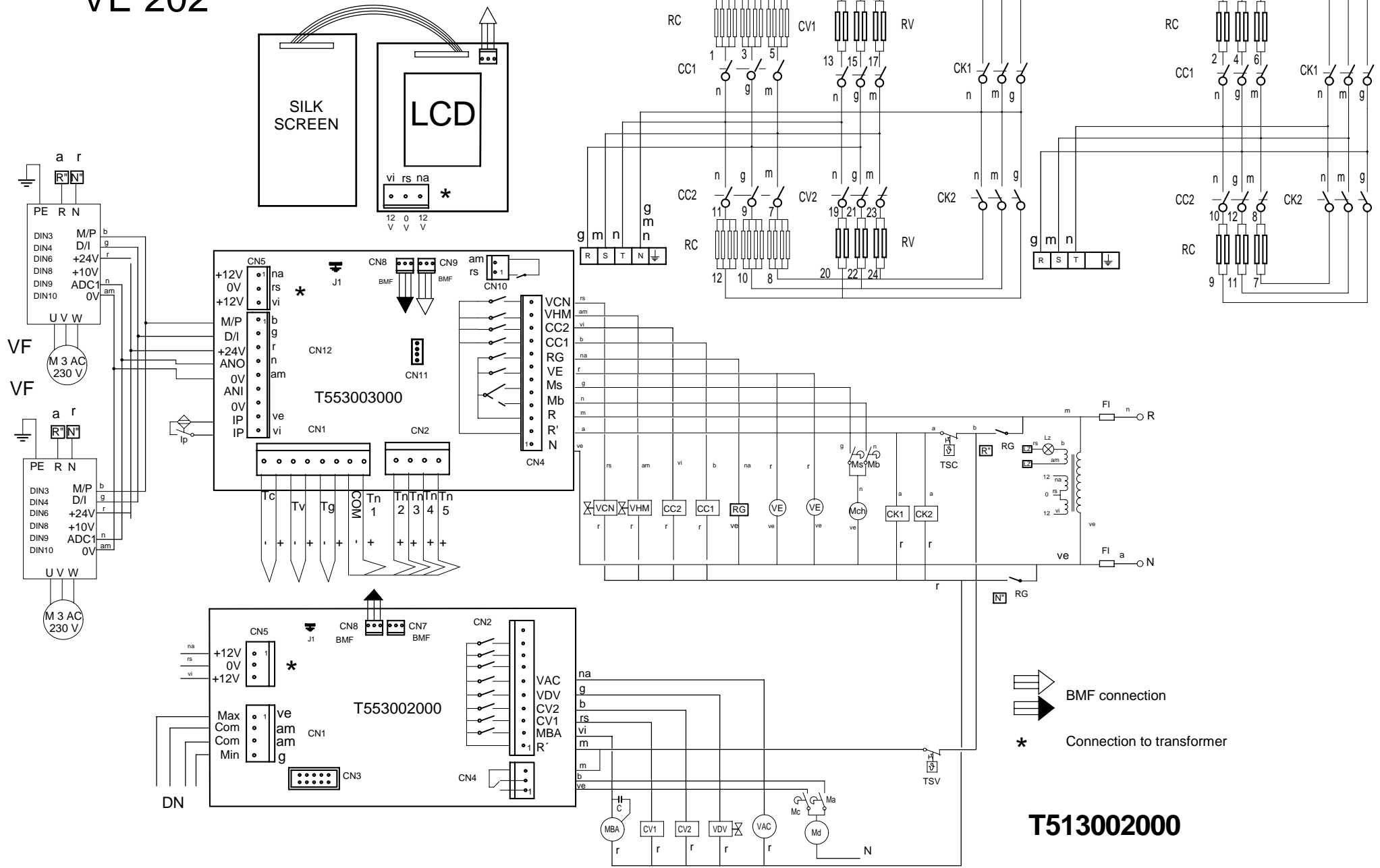

BMF connection

* Connection to transformer



T513002000

VPE 202

3N-50/60Hz 380/415V

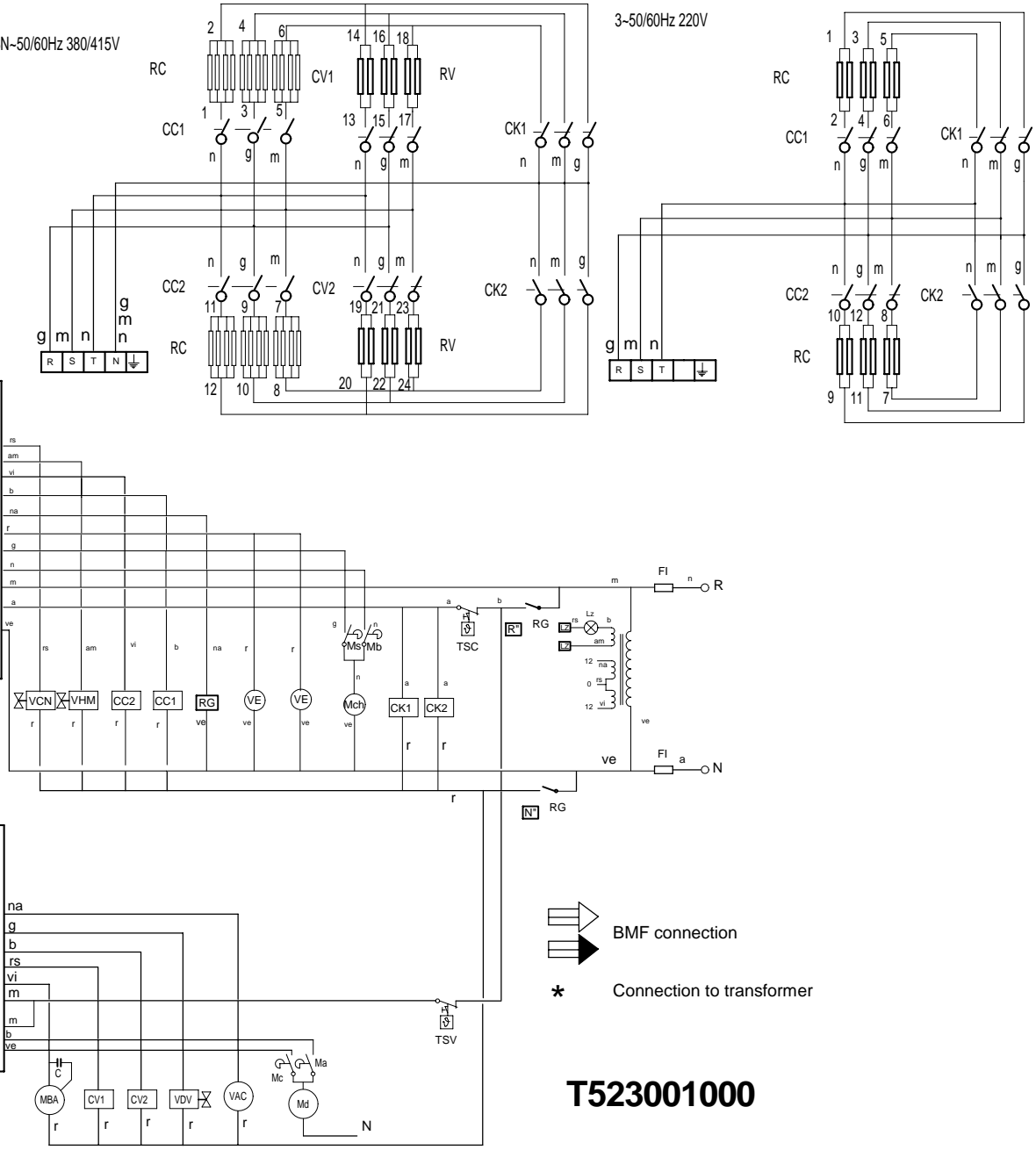
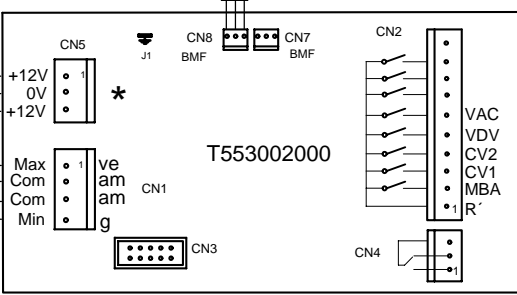
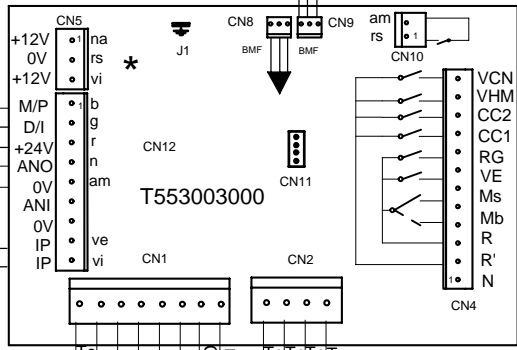
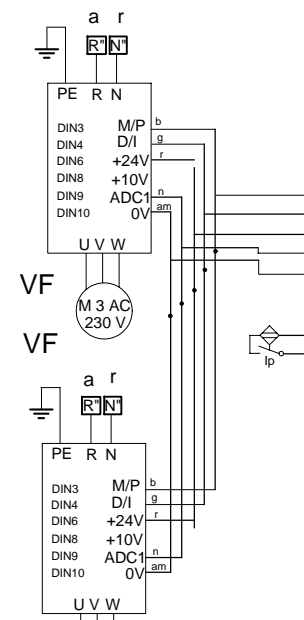
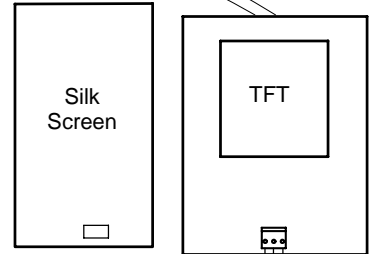
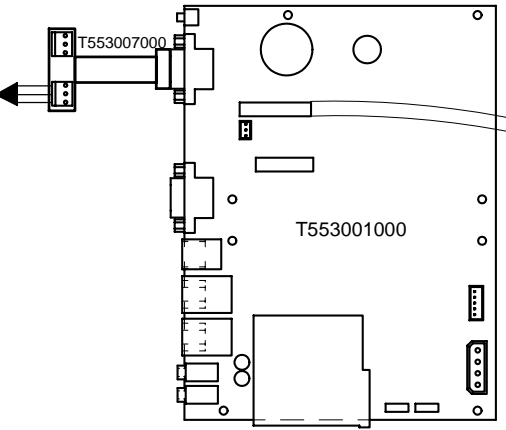
3-50/60Hz 220V



 BMF connection
 Connection to transformer

T523001000

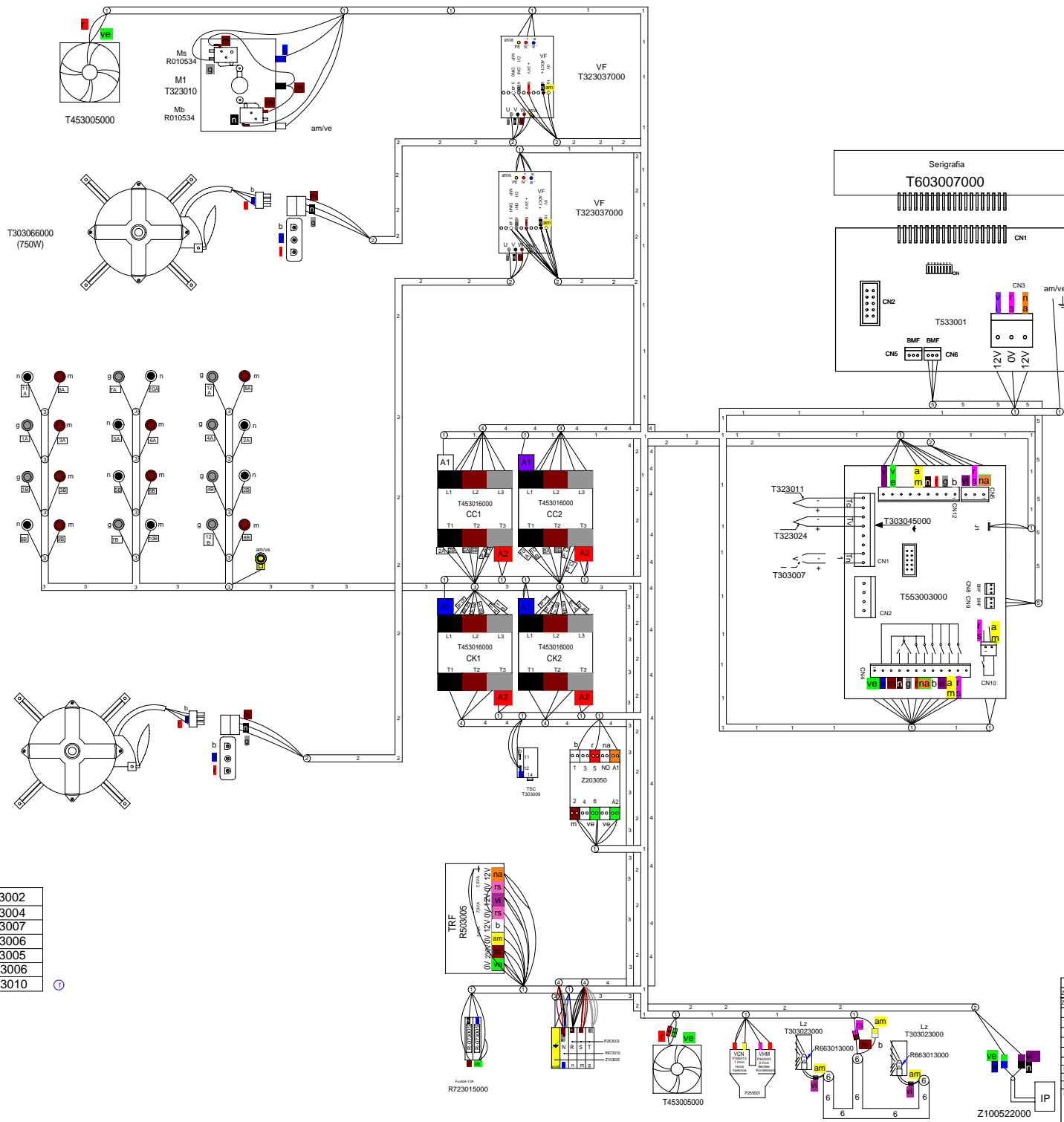

RC 30 kW
T323034 T323035

RC 30 kW
T323034 T323035

Eskema teorikoa	T503002
1	T503004
2	T503007
3	T503006
4	T503005
5	T903006
6	T493010

Muntajko plano: COE 202				T503003000	
Zk.Nº	Pieza	Cant.	Materia/Material	Klas. zk/Nº	Clas.
Zk.Nº	Aldaketak/Modificaciones	Nºrik proposatua/Propuesta de	Data/Fecha	Ganazal akaberu/Tratamiento	
1	T703008 kabletatu aldatu T493010 kabletatu gatik.	jeskibel	2009-07-23	Perdi erorkorak Tolerantziak generatzen	
-	-	-	-	-	-
-	-	-	-	-	-
-	-	-	-	-	-
-	-	-	-	-	-
Marrazlea/Dibujado: e.carrasco 2009-02-23 Proiektatzaile/Proyectado: e.carrasco 2009-02-23 Egiaztatzaile/Comprobado: e.carrasco 2009-02-23 Eskala/Escala:				FAOOR Fagor Industrial, Koop. Elk., Mugatuas	
LABEAK				Ganazal pentada Mecanizado superficial	
Plano hau ezin daterke erabili, ez berritatu, gure baimenik gabe.				Plano Zk./Plano Nº HC-81479 -01 Zk. ord. du. Zk. gatik ord.	

