DESPIECE TECNICO

Hornos a gas
Fours à gaz
Gas ovens
Gas heissluftdämpfer
Forni a gas
Fornos a gás

Modelos:

COG-061

COG-101

VG-101

VPG-101

Enero 2011 January

Revisado Septiembre 2011 / Revised September 2011



F A G O R I N D U S T R I A L

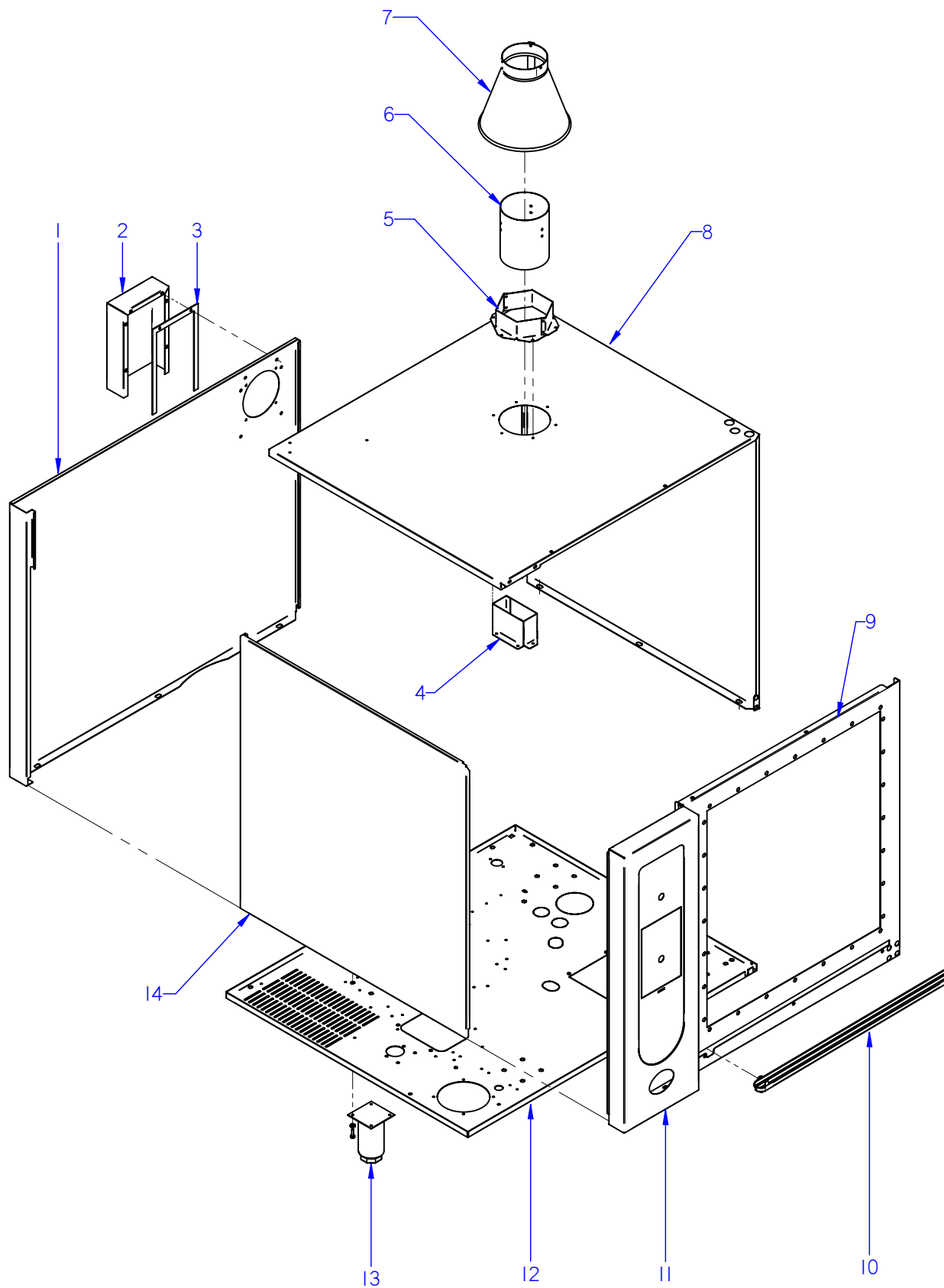

ITEM MARCADO EN COLOR = REPUESTO RECOMENDADO
 COLOURED ITEM = RECOMMENDED SPARE PART

N plano	Firma	Fecha	Aparato	MUEBLE / UNIT	Lamina	Fagor Industrial S.Coop. FAGOR
C-2778	<i>(Signature)</i>	2011-01	HORNOS COG-061 / COG-101		1	Oñate

MOD.		HORNOS / OVEN		ZONA / ZONE		MUEBLE / UNIT				PLANO DIAGRAM		C-2778
ITEM	CODIGO	DENOMINACION	TEXTO	COG-061	COG-101							NOTAS
1	T902802000	PANEL POST. EXTERIOR 6/11	REAR EXTERIOR PANEL 6/11	1	-							
1	T812804000	PANEL POST. EXTERIOR 10/11	REAR EXTERIOR PANEL 10/11	-	1							
2	T812806500	CHAPA SEPARACION IPX5	SEPARATION PLATE IPX5	1	1							
	Q221342000	REMACHE EXAGONAL M5	HEXAGONAL RIVET M.5	6	6							
	Q232030000	ARANDELA A5	WASHER A.5	6	6							
	Q242030000	ARANDELA ABANICO A5 A.304	FAN SHAPED WASHER A.5	6	6							
	Q012031000	TORNILLO EXAGONAL M5x10 A304	HEXAGONAL SCREW M.5x10	6	6							
3	T812811000	JUNTA IPX5	SEAL IPX5	1	1							
4	T012605000	CHIMENEA INTERIOR COMPLETA	COMPLETE INTER. FLUEPIPE	1	1							
5	T832610000	GUIA CHIMENEA	FLUEPIPE GUIDANCE	2	2							
	Q412002000	REMACHE TUBULAR Ø4x7.5	TUBULAR RIVET Ø4x7.5	16	16							
	Q012042000	TORNILLO EXAGONAL M6x15	HEXAGONAL BOLT M6x15	2	2							
	Q232040000	ARANDELA A6	WASHER A.6	2	2							
	Q242040000	ARANDELA ABANICO A6 A.304	FAN SHAPED WASHER A.6	2	2							
6	R292646500	CONDUCTO HUMOS	SMOKE DUCT	1	1							
7	R272612000	CHIMENEA	FLUEPIPE	1	1							
S/Nº	R272614000	SOPORTE CHIMENEA HCG/HGC	CHIMNEY SUPPORT	3	3							
	Q412002000	REMACHE TUBULAR Ø4x7.5	TUBULAR RIVET Ø4x7.5	15	15							
8	T932804000	CUERPO EXTERIOR COG-061	EXTERIOR BODY COG-061	1	-							ELIMINADO 01.03.11
8	T932804500	CUERPO EXTERIOR COG-061	EXTERIOR BODY COG-061	1	-							INTRODUCIDO 01.03.11
8	T832801000	CUERPO EXTERIOR 10/11 HGC	EXTERIOR BODY 10/11 HGC	-	1							ELIMINADO 01.03.11
8	T832801500	CUERPO EXTERIOR 10/11 HGC	EXTERIOR BODY 10/11 HGC	-	1							INTRODUCIDO 01.03.11
9	T912801000	PANEL FRONTAL	FRONT PANEL	1	-							
9	T812801000	PANEL FRONTAL 10-11	FRONT PANEL 10/11	-	1							
	Q221342000	REMACHE EXAGONAL M5	HEXAGONAL RIVET M.5	11	11							
	Q232040000	ARANDELA A6	WASHER A.6	3	3							
	Q242040000	ARANDELA ABANICO A6 A.304	FAN SHAPED WASHER A.6	3	3							
	Q012042000	TORNILLO EXAGONAL M6x15	HEXAGONAL BOLT M6x15	3	3							
	Q222011000	REMACHE EXAGONAL M5 INOX	HEXAGONAL RIVET M5	3	3							

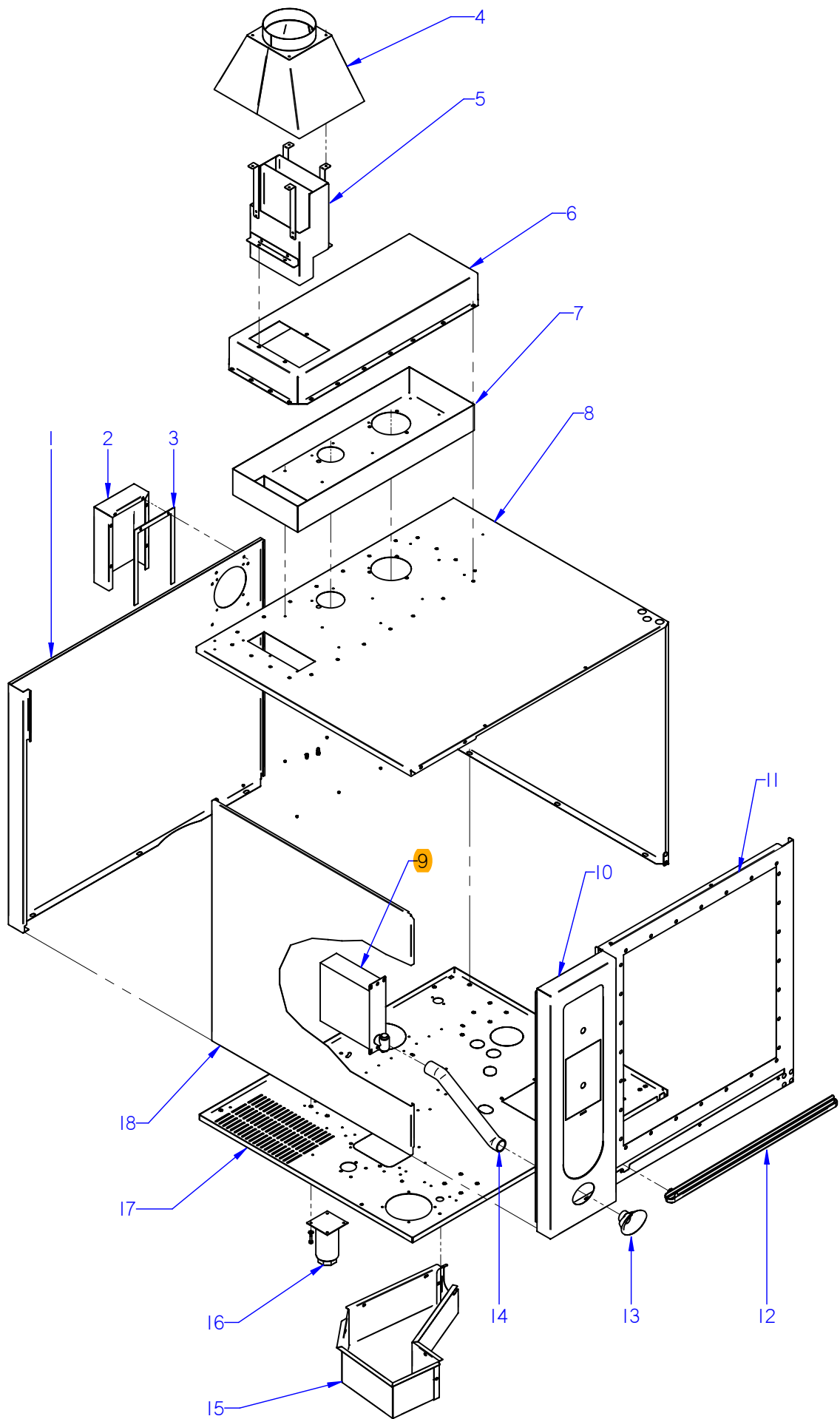

ITEM MARCADO EN COLOR = REPUESTO RECOMENDADO
 COLOURED ITEM = RECOMMENDED SPARE PART

N plano	Firma	Fecha	Aparato	MUEBLE / UNIT	Lamina	Fagor Industrial S.Coop. FAGOR
C-2779	<i>[Signature]</i>	2011-01	HORNOS VG-101 / VPG-101		2	Oñate

MOD.		HORNOS / OVEN		ZONA / ZONE		MUEBLE / UNIT				PLANO DIAGRAM		C-2779	
ITEM	CODIGO	DENOMINACION	TEXTO	VG-101	VPG-101							NOTAS	
1	T842806000	PANEL POST. EXTERIOR 10-11 G	REAR EXTERIOR PANEL10-11G	1	1								
2	T812806500	CHAPA SEPARACION IPX5	SEPARATION PLATE IPX5	1	1								
	Q221342000	REMACHE EXAGONAL M5	HEXAGONAL RIVET M.5	6	6								
	Q232030000	ARANDELA A5	WASHER A.5	6	6								
	Q242030000	ARANDELA ABANICO A5 A.304	FAN SHAPED WASHER A.5	6	6								
	Q012031000	TORNILLO EXAGONAL M5x10 A304	HEXAGONAL SCREW M.5x10	6	6								
3	T812811000	JUNTA IPX5	SEAL IPX5	1	1								
4	T122820000	CHIMENEA EXTERIOR COMPLETA	COMPLETE EXTERIOR FLUEPIPE	1	1								
	Q412002000	REMACHE AVINOX Ø4x10	AVINOX RIVET Ø4x10	12	12								
5	T122816000	SALIDA DE COLECTOR	MANIFOLD OUTPUT	1	1								
S/Nº	T112815000	SOPORTE DE CHIMENEA	CHIMNEY SUPPORT	4	4								
6	T842808500	TAPA BANDEJA COLECTOR	TOP MANIFOLD	1	1								
	3715200000	JUNTA CRISTAL	GLASS SEAL	2	2								
	Q222011000	REMACHE EXAGONAL M5 INOX	HEXAGONAL RIVET M5	3	3								
7	T842805000	BANDEJA DE COLECTOR	COMPL. MANIFOLD TRAY	1	1								
	Q232040000	ARANDELA A6	WASHER A.6	3	3								
	Q242040000	ARANDELA ABANICO A6 A.304	FAN SHAPED WASHER A.6	3	3								
	Q162040000	TUERCA EXAGONAL M6	HEXAGONAL NUT M6	3	3								
	Q222011000	REMACHE EXAGONAL M5 INOX	HEXAGONAL RIVET M5	1	1								
	Q412002000	REMACHE AVINOX Ø4x10	AVINOX RIVET Ø4x10	8	8								
	Q232030000	ARANDELA A5	WASHER A.5	1	1								
	Q242030000	ARANDELA ABANICO A5 A.304	FAN SHAPED WASHER A.5	1	1								
	Q012032000	TORNILLO EXAGONAL M5x15 A304	HEXAGONAL SCREW M.5x15	1	1								
8	T842803000	CUERPO EXTERIOR 10/11 HGV-P	EXTERIOR BODY 10/11 HGV-P	1	1								ELIMINADO 01.03.11
8	T842803500	CUERPO EXTERIOR 10/11 HGV-P	EXTERIOR BODY 10/11 HGV-P	1	1								INTRODUCIDO 01.03.11
	Q222011000	REMACHE EXAGONAL M5 INOX	HEXAGONAL RIVET M5	3	3								
9	T452809000	DUCHA	SHOWER	1	1								
S/Nº	T452834000	MANGO DUCHA	SHOWER HANDLE	1	1								INTRODUCIDO 31.05.10
	Q232030000	ARANDELA A5	WASHER A.5	6	6								
	Q242030000	ARANDELA ABANICO A5 A.304	FAN SHAPED WASHER A.5	6	6								
	Q012032000	TORNILLO EXAGONAL M5x15 A304	HEXAGONAL SCREW M.5x15	6	6								

MOD.		HORNOS / OVEN		ZONA / ZONE		MUEBLE / UNIT				PLANO DIAGRAM		C-2779	
ITEM	CODIGO	DENOMINACION	TEXTO	VG-101	VPG-101							NOTAS	
10	T842811000	PANEL PORTAMANDO HGV 10/11	CONTROL PANEL HGV 10/11	1	—								
10	T852803000	PANEL PORTAMANDO 101 VPG	CONTROL PANEL 101 VPG	—	1								
S/Nº	T812809000	JUNTA PORTAMANDOS VERT 10/11	CONTROL HOLDER SEAL VERT 10/11	1	1								
S/Nº	T842814000	JUNTA PORTAMAND. HORZ 10/11	CONTROL HOLDER SEAL 10/11	1	1								
11	T812801000	PANEL FRONTAL 10-11	FRONT PANEL 10/11	1	1								
	Q221342000	REMACHE EXAGONAL M5	HEXAGONAL RIVET M.5	11	11								
	Q232040000	ARANDELA A6	WASHER A.6	3	3								
	Q242040000	ARANDELA ABANICO A6 A.304	FAN SHAPED WASHER A.6	3	3								
	Q012042000	TORNILLO EXAGONAL M6x15	HEXAGONAL BOLT M6x15	3	3								
	Q222011000	REMACHE EXAGONAL M5 INOX	HEXAGONAL RIVET M5	3	3								
12	T842809000	RECOGEAGUAS PLAST 6-10/11	PLAST SPRING WATER COLLE.	1	1								
	Q242020000	ARANDELA ABANICO A4 A.304	FAN SHAPED WASHER A.4	3	3								
	Q032021000	TORNILLO ALOMADO M4x10	CURVED SCREW M.4x10	3	3								
13	T922801000	EMBELLECEDOR DUCHA	SHOWER TRIM	—	1								
14	3714100000	TUBO SILICONA Ø 38*31	SILICON PIPE Ø 38*31	1	1								
	Q881305000	ABRAZADERA 25*40	CLAMP 25*40	2	2								
15	T650701500	CAJA CUB SIST LIMP VPG 202 SOL.	CLEANING SYSTEM BOX	—	1								ELIMINADO 01.03.11
15	T920701000	CAJA CUBRE BOMBA LAVADO	CLEANING PUMP BOX	—	1								INTRODUCIDO 01.03.11
	Q221342000	REMACHE EXAGONAL M5	HEXAGONAL RIVET M.5	—	9								
S/Nº	T650702000	TAPA CUBRE SISTEMA LAVADO	COVER WASHING SYSTEM BOX	—	1								ELIMINADO 01.03.11
S/Nº	T330752500	TAPA SISTEMA LAVADO	TOP WASHING SYSTEM	—	1								INTRODUCIDO 01.03.11
	Q242030000	ARANDELA ABANICO A5 A.304	FAN SHAPED WASHER A.5	—	9								
	Q152004000	TORNILLO APLAST. M5X13 A 304	FLAT SCREW M.5x13	—	9								
S/Nº	T550702000	GUIA1 CAJA CUBRE SIST LAVADO	GUIDE1 WASHING SYSTEM BOX	—	1								ELIMINADO 01.03.11
S/Nº	T550701000	GUIA2 CAJA CUBRE SIST LAVADO	GUIDE2 WASHING SYSTEM BOX	—	1								ELIMINADO 01.03.11
16	X260151000	PATA REGULABLE	REGULABLE LEG	4	4								
	Q232040000	ARANDELA A6	WASHER A.6	16	16								
	Q242040000	ARANDELA ABANICO A6 A.304	FAN SHAPED WASHER A.6	16	16								
	Q012043000	TORNILLO EXAGONAL M6X20 A304	HEXAGONAL SCREW M6X20	16	16								

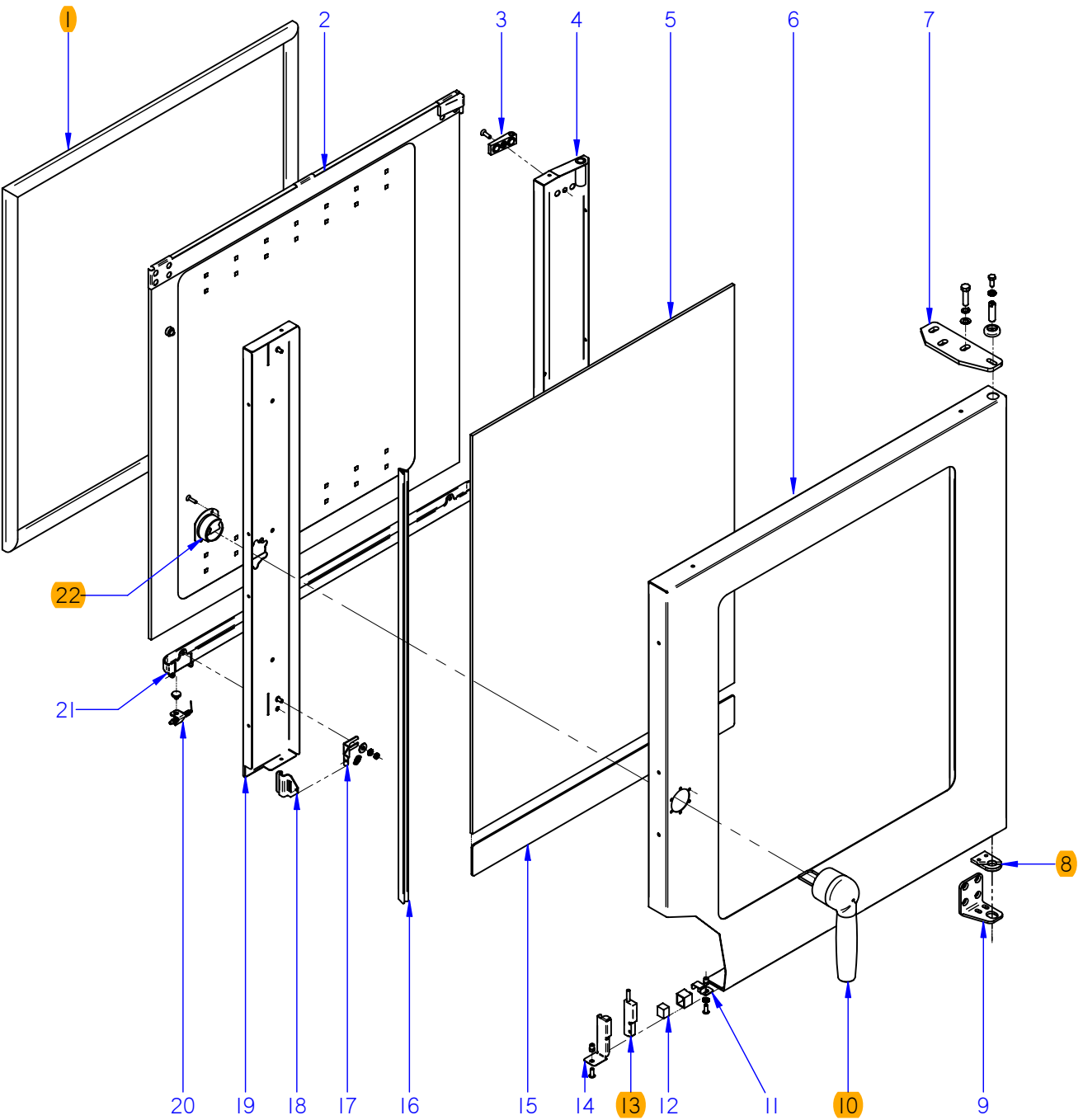

ITEM MARCADO EN COLOR = REPUESTO RECOMENDADO
 COLOURED ITEM = RECOMMENDED SPARE PART

N plano C-2780	Firma <i>(Firma)</i>	Fecha 2011-01	Aparato HORNOS COG; VG; VPG 061 / 101	PUERTA	Lamina 3	Fagor Industrial S. Coop. Omate
-------------------	-------------------------	------------------	--	--------	-------------	------------------------------------



MOD.		HORNOS / OVEN		ZONA / ZONE		PUERTA / DOOR				PLANO DIAGRAM		C-2780	
ITEM	CODIGO	DENOMINACION	TEXTO	COG-061	COG-101	VG-101	VPG-101					NOTAS	
	1100003139	KIT PUERTA 6/11 COMPL.	DOOR 6/11 KIT	1	-	-	-						
	1100003141	KIT PUERTA 10/11 COMPL.	DOOR 10/11 KIT	-	1	1	1						
1	R660503000	JUNTA DE PUERTA 6/11	DOOR JOINT 6/11	1	-	-	-						
1	R670500000	JUNTA DE PUERTA 10/11	DOOR JOINT 10/11	-	1	1	1						
S/Nº	R660526000	FIJACION JUNTA DE PUERTA 6/11	DOOR SEAL FASTENING 6/11	1	-	-	-						
S/Nº	R670513000	FIJACION JUNTA DE PUERTA 10/11	DOOR SEAL FASTENING 10/11	-	1	1	1						
	Q032021000	TORNILLO ALOMADO M4X10	CURVED SCREW M.4x10	24	28	28	28						
2	1100003130	KIT CRISTAL INTER. 6/11	6/11 INNER GLASS KIT	1	-	-	-						
2	1100003132	KIT CRISTAL INTER. 10/11	10/11 INNER GLASS KIT	-	1	1	1						
3	R670615000	BASE DE BISAGRA	HINGE BASE	2	2	2	2						
	Q042032000	TORNILLO AVELLANADO M5X15	COUNTERSUNK SCREW M.5x15	2	2	2	2						
4	T900505000	CONTRAPUERTA BISAGRA 6/11	INNER DOOR HINGE 6/11	1	-	-	-						
4	T840504000	CONTRAPUERTA BISAGRA 10/11	INNER DOOR HINGE 10/11	-	1	1	1						
	Q221341000	REMACHE EXAGONAL M.4	HEXAGONAL RIVET M.4	1	1	1	1						
	Q222011000	REMACHE EXAGONAL M.5	HEXAGONAL RIVET M.5	2	2	2	2						
5	R660610000	CRISTAL EXTERIOR 6/11	EXTERNAL GLASS 6/11	1	-	-	-						
5	R670627000	CRISTAL EXTERIOR 10/11	EXTERNAL GLASS 10/11	-	1	1	1						
	R670617000	TOPE CRISTAL INTERIOR	INTERIOR GLASS BUFFER	3	4	4	4						
6	T900501500	PANEL PUERTA 6/11	DOOR PANEL 6/11	1	-	-	-						
6	T840501500	PANEL PUERTA 10/11	DOOR PANEL 10/11	-	1	1	1						
S/Nº	T900508000	CALZO PUERTA	DOOR WEDGE	1	1	1	1						
	Q242040000	ARANDELA ABANICO A6 A.304	FAN SHAPED WASHER A.6	2	2	2	2						
	Q012041000	TORNILLO EXAGONAL M6x10	HEXAGONAL BOLT M6x10	2	2	2	2						
	Q062040000	TORNILLO AVELLANADO M6x16	COUNTERSUNK SCREW M6x16	4	4	4	4						
7	T130500000	BISAGRA SUPERIOR	UPPER HINGE	1	1	1	1						
	Q302025000	ARANDELA 8,4X20X1.5	FLAT WASHER 8,4X20X1.5	3	3	3	3						
	Q261050000	ARANDELA MUELLE A8	SPRING WASHER A8	3	3	3	3						
	Q012055000	TORNILLO EXAGONAL M8X30	HEXAGONAL BOLT M8X30	3	3	3	3						
S/Nº	R660534000	EJE SUPERIOR	UPPER SHAFT	1	1	1	1						
	R662807000	ARANDELA AMARRE	DOOR ANCHORING WASHER	1	1	1	1						
	Z850519000	RESORTE 06329	SPRING 06329	1	1	1	1						

MOD.		HORNOS / OVEN	ZONA / ZONE	PUERTA / DOOR				PLANO DIAGRAM	C-2780
ITEM	CODIGO	DENOMINACION	TEXTO	COG-061	COG-101	VG-101	VPG-101		NOTAS
8	R660549000	GUIA EJE INFERIOR FUNDIDO	LOWER SHAFT GUIDE	1	1	1	1		
	Q062040000	TORNILLO AVELLANADO M6X16	COUNTERSUNK SCREW M.6x16	4	4	4	4		
9	R660551000	BISAGRA INFERIOR PLEGADA	LOWER FOLDER HINGE	1	1	1	1		
10	T900506000	MANILLA COMPLETA	HANDLE	1	1	1	1		
	Q042022000	TORNILLO AVELLANADO M4X15	COUNTERSUNK SCREW M.4x15	3	3	3	3		
11	T130513000	SOPORTE IMAN	MAGNET HOLDER	1	1	1	1		
	Q222011000	REMACHE EXAGONAL M.5	HEXAGONAL RIVET M.5	1	1	1	1		
	Q242030000	ARANDELA ABANICO A5 A.304	FAN SHAPED WASHER A.5	1	1	1	1		
	Q152004000	TORNIL. APLASTADO M5X13 A 304	FLAT SCREW M.5x13	1	1	1	1		
12	Z200506000	IMAN	MAGNET	1	1	1	1		
S/Nº	Z200507000	PROTECTOR IMAN	MAGNET PROTECTOR	1	1	1	1		
13	Z100522000	INTERRUPTOR MAGNETICO AC	MAGNETIC SWITCH AC	1	1	1	1		
14	T302819000	SOPORTE MICRO PUERTA	DOOR MICRO SWITCH	1	1	1	1		
	Q152004000	TORNIL. APLASTADO M5X13 A 304	FLAT SCREW M.5x13	1	1	1	1		
15	T800501000	TOPE CRISTAL EXTERIOR 10/11	EXTERNAL GLASS STOP	1	1	1	1		
16	3715200000	JUNTA CRISTAL	WINDOW SEAL	2	2	2	2		
17	R670612000	BASE DE PESTILLO	LATCH BASE	2	2	2	2		
18	R670613000	PESTILLO	LATCH	2	2	2	2		
	R660605000	MUELLE TENSOR	LATCH TENSOR SPRING	2	2	2	2		
	Q302022000	ARANDELA 16X6X1.2 A.304	FLAT WASHER 16x6x1,2	2	2	2	2		
	Q242030000	ARANDELA ABANICO A5 A.304	FAN SHAPED WASHER A.5	2	2	2	2		
	Q162030000	TUERCA EXAGONAL M5	HEXAGONAL NUT M.5	2	2	2	2		
19	T900504000	CONTRAP MANILLA COMPL 6/11	COMPLETE HANDLE DOOR 6/11	1	-	-	-		
19	T840502000	CONTRAP MANILLA COMPL 10/11	COMPLETE HANDLE DOOR 10/11	-	1	1	1		
	Q221341000	REMACHE EXAGONAL M4	HEXAGONAL RIVET M.4	3	3	3	3		
20	T840508000	CIERRE RECOGEAGUAS	WATER COLLECTOR COVER	1	1	1	1		
	T300518000	TAPON CIERRE CANALETA	CAP CHANNEL COVER	1	1	1	1		ELIMINADO 01.03.11
	T840510000	JUNTA CIERRE RECOGEAGUAS	JOINT WATER COLLECTOR COV	1	1	1	1		INTRODUCIDO 01.03.11
	T840509000	MUELLE CIERRE RECOGEAGUAS	SPRING WATER COLLECTOR CO	1	1	1	1		
21	T840506000	RECOGEAGUAS PUERTA 6-10/11	DOOR SPRING WATER COLLECT	1	1	1	1		
	Q042022000	TORNILLO AVELLANADO M4X15	COUNTERSUNK SCREW M.4x15	2	2	2	2		

N plano
C-2781
Firma
Fecha
2011-01
Aparato
HORNO COG- / VG / VPG-061/101
MUEBLE INTERIOR / INTERIOR OVEN
Lamina
4
Fagor Industrial S. Coop. **FAGOR**
Omate

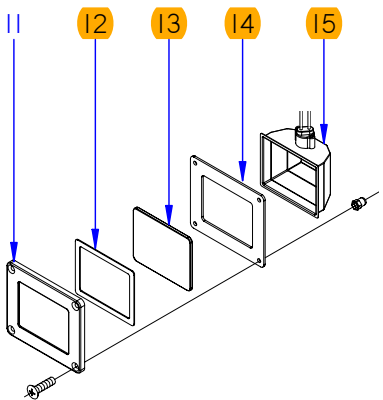

DETALLE DE LAMPARA

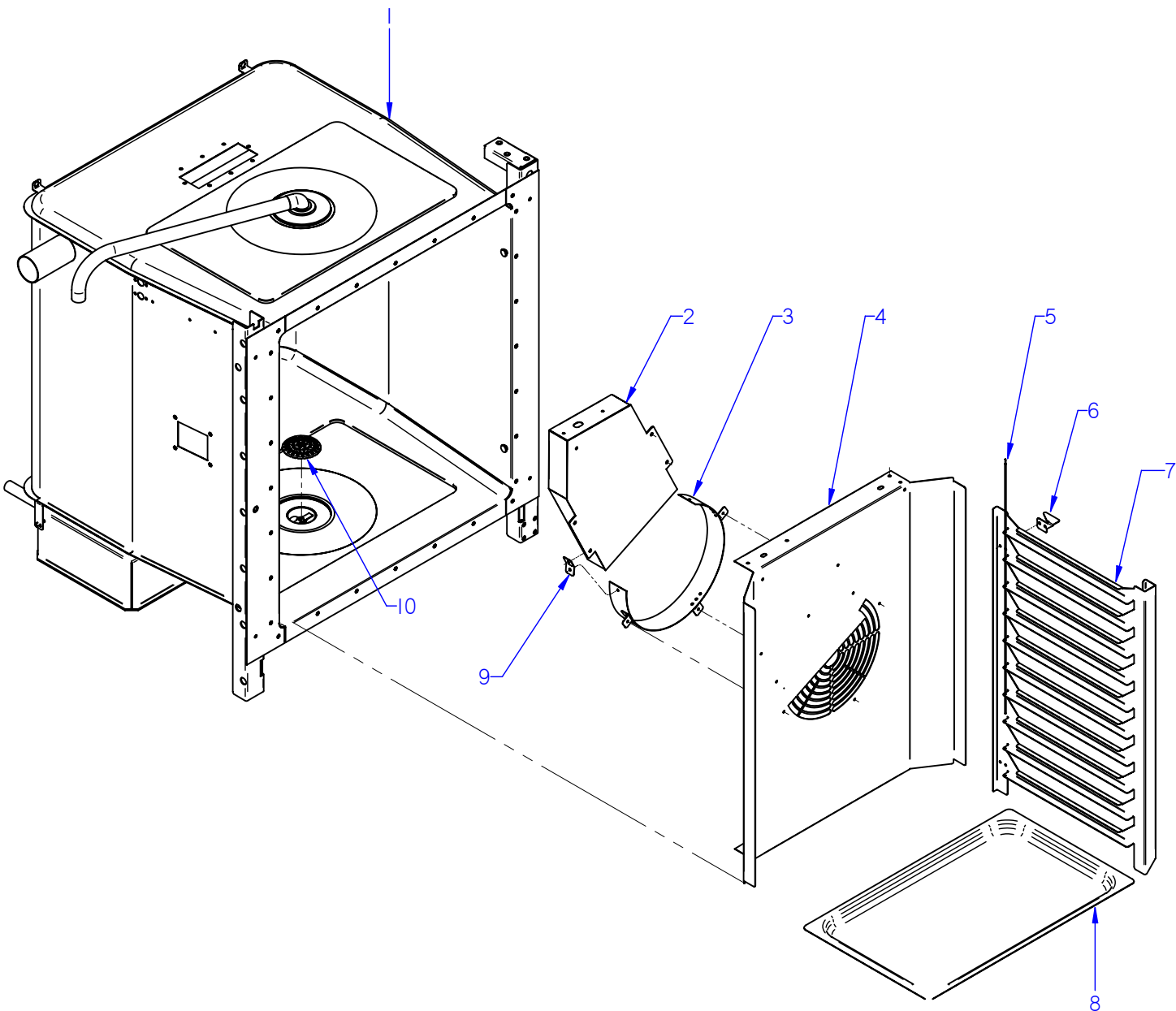

ITEM MARCADO EN COLOR = REPUESTO RECOMENDADO
COLOURED ITEM = RECOMMENDED SPARE PART

MOD.		HORNOS / OVEN		ZONA / ZONE		MUEBLE INTERIOR / INTERIOR OVEN				PLANO DIAGRAM		C-2781
ITEM	CODIGO	DENOMINACION	TEXTO	COG-061	COG-101	VG-101	VPG-101					NOTAS
1	T932602000	CUERPO INTERIOR COG-061	INTERIOR BODY COG-061	1	-	-	-					
1	T832601000	CUERPO INTERIOR HGC-10/11	INTERIOR BODY HGC-10/11	-	1	-	-					
1	T842601000	CUERPO INTERIOR HGV-10/11	INTERIOR BODY HGV-10/11	-	-	1	-					
1	T852601000	CUERPO INTERIOR HGP-10/11	INTERIOR BODY HGP-10/11	-	-	-	1					
S/Nº	T360712000	PUNTA DIFUSORA LAVADO	WASHING DISPENSER POINT	-	-	-	1					
2	T932607000	CORBATA SOLDADA COG-061	WELD TIE COG-061	1	-	-	-					
2	T832606000	CORBATA SOLDADA HGC-10/11	WELD TIE HGC-10/11	-	1	-	-					
2	T142639000	CONDUCTO DE HUMOS	SMOKE DUCT	-	-	1	1					
	Q412002000	REMACHE AVINOX Ø4x10	RIVET AVINOX Ø4x10	18	18	18	18					
S/Nº	T082619000	FIJACION CORBATA	FIXING TIE	6	6	-	-					INTRODUCIDO 01.06.11
3	T932606000	SUPLEMEN. CUBREVEN. COG-061	FAN COVER SUPPLE. COG-061	1	-	-	-					
3	T832611000	SUPLEMEN. CUBREVEN. COG-101	FAN COVER SUPPLE. COG-101	-	1	-	-					
3	T132645000	SUPLEMEN. CUBREVEN. ABIERTO	FAN COVER SUPPLEMEN. OPE	-	-	1	1					
4	T932604000	CUBREVENTILADOR COG-061	FAN COVER COG-061	1	-	-	-					
4	T832605000	CUBREVENTILADOR HGC 10/11	FAN COVER HGC 10/11	-	1	-	-					
4	T112665000	CUBREVENTILADOR HGV 10/11	FAN COVER HGV 10/11	-	-	1	1					
S/Nº	T302643000	FIJACIÓN SUPLEMENTO	FAN COVER SUPPLEM. BINDING	7	11	4	4					
5	R662693000	TOPE DE PORTABANDEJAS 6/11	TRAY HOLDER BUFFER 6/11	2	-	-	-					
5	R672692000	TOPE DE PORTABANDEJAS 10/11	TRAY HOLDER BUFFER 10/11	-	2	2	2					
6	R672691000	ESCUADRA SUJECCION 6-10/11	FASTENING BRACKET 6-10/11	4	4	4	4					
	Q412002000	REMACHE AVINOX Ø4x10	RIVET AVINOX Ø4x10	8	8	8	8					
7	R692616000	GUIA BANDEJAS DERECHA 6/11	RIGHT TRAY GUIDE 6/11	1	-	-	-					
7	R672612000	GUIA BANDEJAS DERECHA 10/11	RIGHT TRAY GUIDE 10/11	-	1	1	1					
S/Nº	R692617000	GUIA BANDEJAS IZQUIERDA 6/11	LEFT TRAY GUIDE 6/11	1	-	-	-					
S/Nº	R672613000	GUIA BANDEJAS IZQUIERDA 10/11	LEFT TRAY GUIDE 10/11	-	1	1	1					
8	R252816000	BANDEJA 1/1 P:20	TRAY 1/1 P:20	1	1	1	1					
S/Nº	R672665000	PARRILLA 1X1 (REF. 2025201)	GRILLE 1X1 (REF. 2025201)	1	1	1	1					
9	T142640000	PESTAÑA CIERRE CUBREVENTILAD	FAN COVER LOCK TAB	-	-	2	2					
10	T642657000	FILTRO DESAGÜE	DRAINAGE FILTER	1	1	1	1					

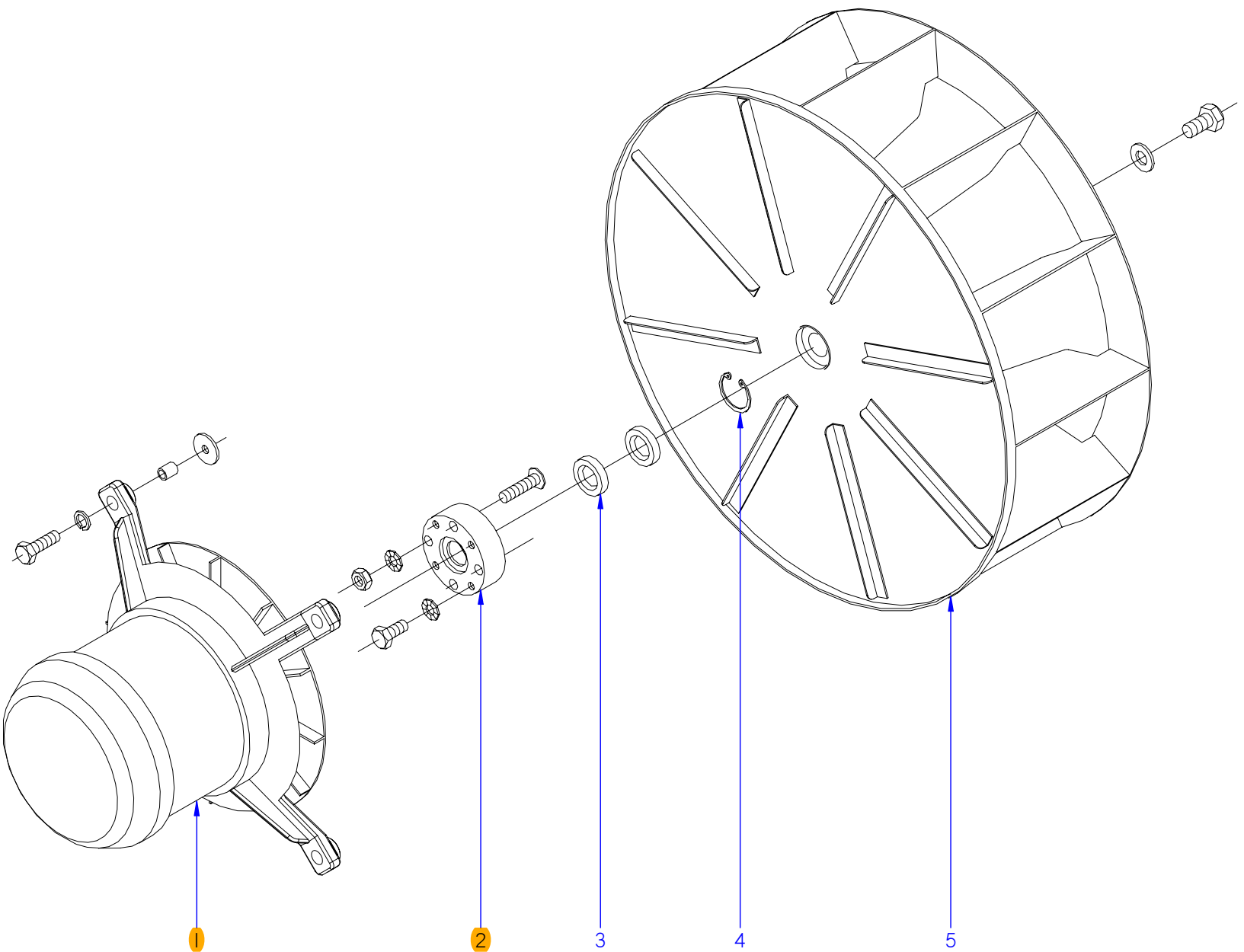

ITEM MARCADO EN COLOR = REPUESTO RECOMENDADO
COLOURED ITEM = RECOMMENDED SPARE PART

N plano	Firma	Fecha	Aparato	Lamina	Fogor Industrial S. Coop.
C-2782		2011-01	HORNOS COG / VG / VPG-061/101	5	Onate
			TURBINA / TURBINE		

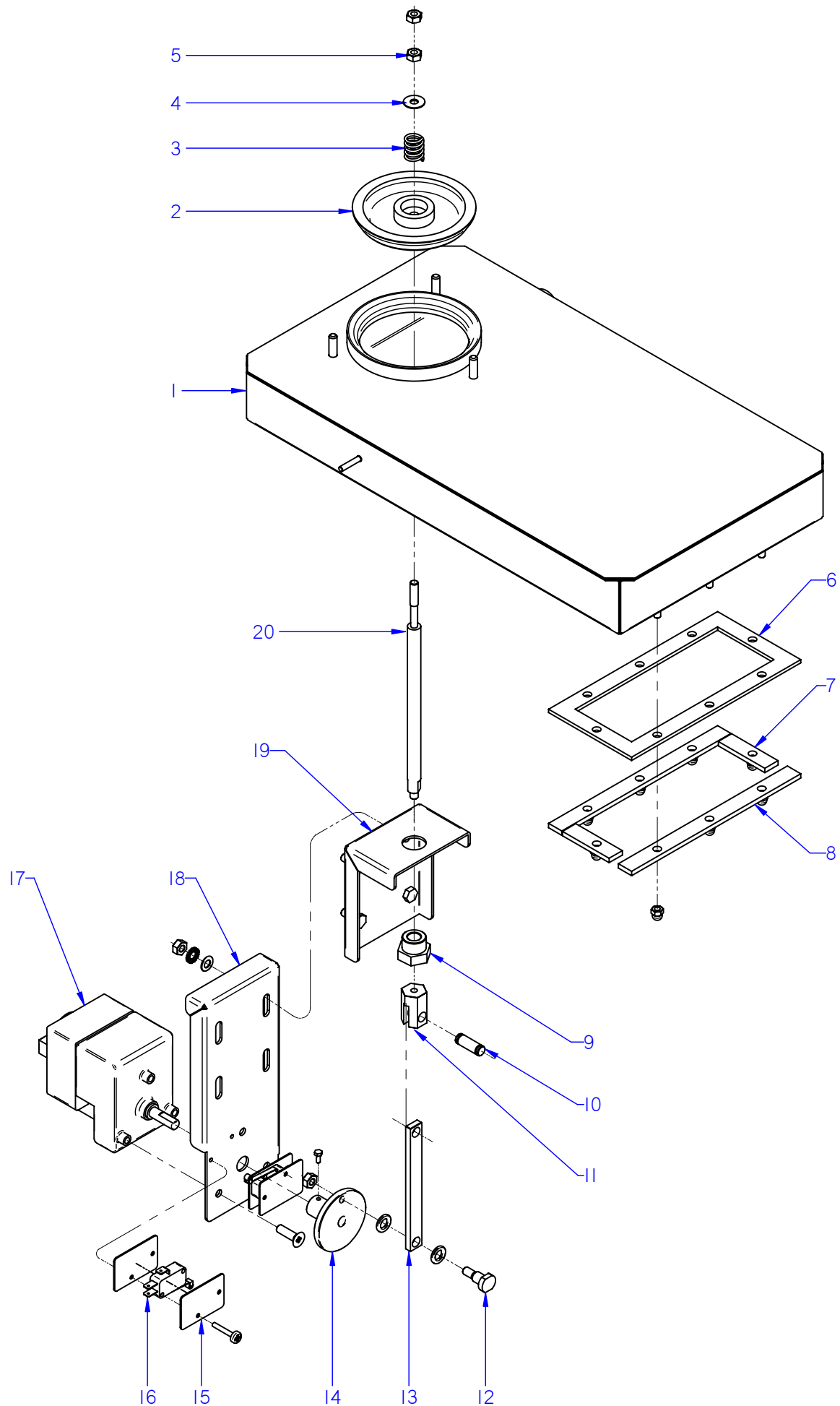

ITEM MARCADO EN COLOR = REPUESTO RECOMENDADO
 COLOURED ITEM = RECOMMENDED SPARE PART

N plano	Firma	Fecha	Aparato	CHIMENEA / CHIMNEY	Lamina	Fagor Industrial S.Coop. FAGOR
C-2783	<i>(Signature)</i>	2011-01	HORNOS VG-101 / VPG-101		6	Oñate

MOD.		HORNOS / OVEN	ZONA / ZONE	CHIMENEA / CHIMNEY						PLANO DIAGRAM	C-2783
ITEM	CODIGO CODE	DENOMINACION	NAME	VG-101	VPG-101					NOTAS	
1	T842608000	CHIMENEA COM. HGV-10/11	COMPLET. CHIMNEY HGV-10/11	1	1						
1	T852603000	CHIMENEA COM. HGP 10/11	COMPLET. CHIMNEY HGP 10/11	1	1						
2	T115115000	RETENCION DE VAPORES	CLOSE CHIMNEY	1	1						
3	R725008000	RESORTE	SPRING	1	1						
4	Q302022000	ARANDELA 16X6X1.2 A.304	FLAT WASHER 16x6x1,2	2	2						
5	Q162040000	TUERCA EXAGONAL M6	HEXAGONAL NUT M.6	2	2						
6	T122630000	JUNTA CHIMENEA	FLUEPIPE SEAL	1	1						
7	T132634000	PLETINA REF CORTO INFERIOR	BOTTOM DECK	2	2						
	Q232030000	ARANDELA A5	FLAT WASHER A.5	8	8						
	Q242030000	ARANDELA ABANICO A5 A.304	FAN SHAPED WASHER A.5	8	8						
	Q213131000	TUERCA SOMBRERETE M5	SOMBRERETE NUT M5	8	8						
8	T122631000	PLETINA REF LARGO INFERIOR	LONG BOTTOM DECK	2	2						
9	R725030000	TUERCA GUIA RETENCION	RETAINER NUT GUIDE	1	1						
	Q307067000	JUNTA TORICA 9.19x2.62	O-RING 9.19x2.62	1	1						
10	T135046000	EJE DE GUIA DE RETENCION	GUIDE SHAFT HOLDING	1	1						
	Q271033000	ARANDELA DE SEGURIDAD 6	SAFETY WASHER 6	2	2						
11	T135045000	SUPLEMEN. EJE DE RETENCION	AXIS CHARGE RETENTION	1	1						
12	T135009000	EJE DE LEVA	CAM SHAFT	1	1						
	Q308013000	ARANDELA Ø14xØ8x2	FLAT WASHER Ø14xØ8x2	2	2						
	Q162040000	TUERCA EXAGONAL M6	HEXAGONAL NUT M.6	1	1						
13	T845012000	PALANCA DE ELEVACION	LIFT LEVER	1	1						
14	T135012000	LEVA	CAM	1	1						
	Q151320000	TORNILLO ALOMADO M4X6 ZINC.	CURVED SCREW M4X6 ZINC.	2	2						
15	R010535000	PLACA SEPARADORA	SPACER PLATE	4	4						
	Q032013000	TORNILLO ALOMADO M3X20	CURVED SCREW M3X20	4	4						
	Q221350000	TUERCA AUTOBLOCANTE M3	SELF-LOCKING NUT M3	4	4						
16	R010534000	INTERRUPTOR PUERTA	DOOR SWITCH	2	2						
17	T113010000	MOTOR CHIMENEA	FLUEPIPE MOTOR	1	1					ELIMINADO 01.02.11	
17	T843011000	MOTOR CHIMENEA A GAS	FLUEPIPE MOTOR	1	1					INTRODUCIDO 01.02.11	
	Q042031000	TORNILLO AVELLANADO M5x10	COUNTERSUNK SCREW M.5x15	3	3						

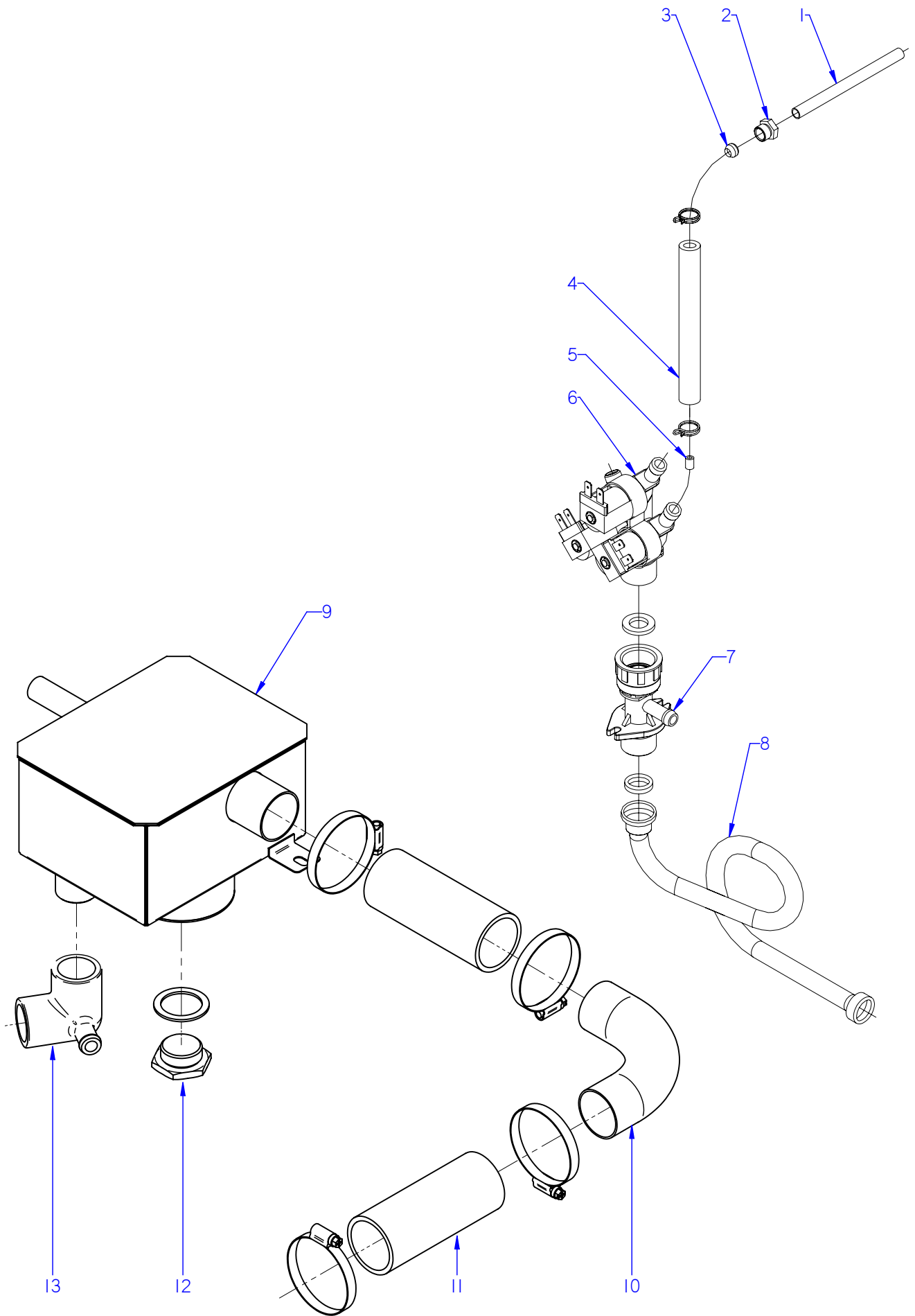

ITEM MARCADO EN COLOR = REPUESTO RECOMENDADO
 COLOURED ITEM = RECOMMENDED SPARE PART

N plano	Firma	Fecha	Aparato	CONDUCCIONES DE AGUA / WATER PIPES	Lamina	Fagor Industrial S.Coop. FAGOR
C-2784	<i>[Signature]</i>	2011-01	HORNOS COG-061 / 101 / VG-101		7	Oñate

MOD.		HORNOS / OVEN		ZONA / ZONE		CONDUCCIONES DE AGUA / WATER PIPES				PLANO DIAGRAM		C-2784	
ITEM	CODIGO CODE	DENOMINACION	NAME	COG-601	COG-101	VG-101							NOTAS
1	R695033000	TUBO INYECTOR 6/11	INJECTOR PIPE 6/11	1	1	1							
2	R695003000	MANGUITO CIERRE	CLOSING SLEEVE	1	1	1							
3	R695004000	BICONO	BICONE	1	1	1							
4	3676900000	TUBO GOMA NEGRA Ø17*10	BLACK RUBBER PIPE Ø17*10	1	1	1							
	Q901310000	ABRAZADERA ELASTICA 16.8-17.7	ELASTIC CLAMP 16.8-17.7	2	2	2							
5	R665041000	REGULADOR 0,25L ROJO	0.25 L RED REGULATOR	1	1	1							
6	Z701135000	E.V.SIMP.220V COD.255.208	E.V.SIMP.220V COD.255.208	1	1	—							
6	Z611123000	ELECTR. TRIPLE COD.255.641	TRIPLE SOLENOID VALVE 255.6	—	—	1							
7	T645006000	ENTRADA DE AGUA COMPLETA	COMPLETE WATER INLET	—	—	1							
	Q307031000	JUNTA TUBO 14X24X3	JOINT 14X24X3	—	—	2							
	Q012021000	TORNILLO EXAGONAL M4x10 A304	HEXAGONAL BOLT M4x10 A304	—	—	2							
	Q162020000	TUERCA EXAGONAL M4	HEXAGONAL NUT M.4º	—	—	2							
8	Z601114000	MANGUERA ENTRADA AGUA	WATER INTAKE HOSE	1	1	1							
9	T835001000	CAJA DESAGÜE COMPL. HGC	COMPL. DRAINAGE BOX G HGC	1	1	—							
9	T845001000	CAJA DESAGÜE COMPL. HGV	COMPL. DRAINAGE BOX G HGV	—	—	1							
	Q232040000	ARANDELA A6	WASHER A6	1	1	1							
	Q242040000	ARANDELA ABANICO A6	FAN WASHER A6	1	1	1							
	Q012042000	TORNILLO EXAGONAL M6X15 A304	HEXAGONAL BOLT M6X15 A304	1	1	1							
10	T815001000	CONDUCCIÓN DESAGÜE 6-10/11 E	DRAINAGE DUCT 6-10/11 E	1	1	1							ELIMINADO 02.05.11
11	3715800000	TUBO SILICONA ALTA Tª Ø43*57	HIGH SILICON PIPE Tª Ø43*57	2	2	2							ELIMINADO 02.05.11
	Q901312000	ABRAZADERA ELASTI. Ø50,6-53,2	ELAST. CLAMP Ø50,6-53,2	4	4	4							
12	T305052000	TAPÓN DESAGÜE	DRAINING PLUG	1	1	1							
	T305053000	JUNTA DESAGÜE	DRAINAGE BOARD	1	1	1							
13	R665080000	CODO DESAGUE	DRAIN ELBOW	1	1	1							

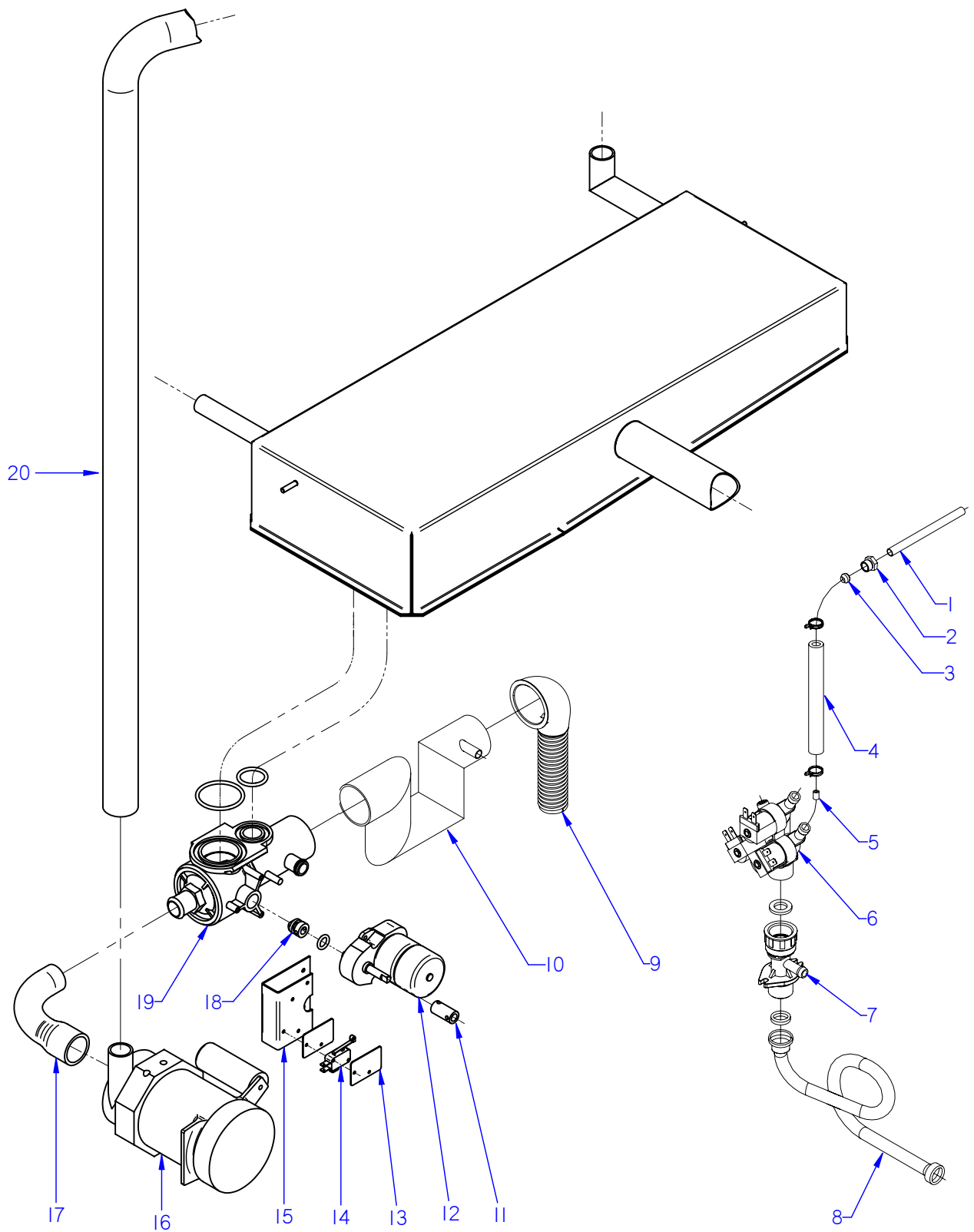

ITEM MARCADO EN COLOR = REPUESTO RECOMENDADO
 COLOURED ITEM = RECOMMENDED SPARE PART

N plano	Firma	Fecha	Aparato	CONDUCCIONES DE AGUA / WATER PIPES	Lamina	Fagor Industrial S.Coop. FAGOR
C-2785	<i>[Signature]</i>	2011-01	HORNOS VPG-101		8	Oñate

MOD.		HORNOS / OVEN		ZONA / ZONE		CONDUCCIONES DE AGUA / WATER PIPES				PLANO DIAGRAM		C-2785	
ITEM	CODIGO CODE	DENOMINACION	NAME	VPG-101								NOTAS	
S/Nº	1100003163	KIT VALVULA DE LAVADO COMP.	WASHING VALVE KIT	1									
1	R695033000	TUBO INYECTOR 6/11	INJECTOR PIPE 6/11	1									
2	R695003000	MANGUITO CIERRE	CLOSING SLEEVE	1									
3	R695004000	BICONO	BICONE	1									
4	3676900000	TUBO GOMA NEGRA Ø17*10	BLACK RUBBER PIPE Ø17*10	1									
	Q901310000	ABRAZADERA ELASTICA 16.8-17.7	ELASTIC CLAMP 16.8-17.7	1									
5	R665041000	REGULADOR 0,25L ROJO	0.25 L RED REGULATOR	1									
6	Z611123000	ELECTR. TRIPLE COD.255.641	TRIPLE SOLENOID VALVE 255.6	1									
7	T645006000	ENTRADA DE AGUA COMPLETA	COMPLETE WATER INLET	1									
	Q307031000	JUNTA TUBO 14X24X3	JOINT 14X24X3	2									
8	Z601114000	MANGUERA ENTRADA AGUA	WATER INTAKE HOSE	1									
9	Z200910000	MANGUERA DESAGUE	DRAINAGE HOSE	1									
10	T360718000	SIFON SALIDA VALVULA	VALVE OUTPUT SIPHON	1									
	Q881307000	ABRAZADERA 40-60	CLAMP 40-60	1									
11	T330733000	CASQUILLO MOTOR MICRO	MICRO MOTOR BUSHING	1									
	Q151320000	TORNILLO ALOMADO M4X6 H.ZIN.	CURVED SCREW M4X6 H.ZIN.	2									
	Q371026000	MANGUITO SUJEC. 4X14 DIN1481	HOSE FASTENING 4X14 DIN1481	1									
	Q052032000	TORNILLO ALLEN M.5x15(+)	ALLEN HEAD SCREW M.5x15(+)	2									
12	T330711000	MOTOR VALVULA	VALVE MOTOR	1									
	Q042022000	TORNILLO AVELLANADO M4X15	COUNTERSUNK SCREW M.4x15	2									
13	R010535000	PLACA SEPARADORA	SPACER PLATE	4									
	Q032013000	TORNILLO ALOMADO M3X20	CURVED SCREW M3X20	4									
	Q221350000	TUERCA AUTOBLOCANTE M3	SELF-LOCKING NUT M3	4									
14	R010534000	INTERRUPTOR PUERTA	DOOR SWITCH	2									
15	T330713000	CHAPA SUJECCION MICROS	FASTENING PLATE MICROS	1								ELIMINADO 01.03.11	
15	T330754000	SOPORTE MICROS LAVADO	MICROS WASH STAND	1								INTRODUCIDO 01.03.11	
16	Z258976000	MOTOBOM. ACLARADO ACC 60HZ	RINSE MOTOR PUMP ACC 60HZ	1									
S/Nº	T820701000	SOPORTE MOTOBOMBA 6-10/11	MOTOR PUMP SUPPORT 6-10/11	1								ELIMINADO 01.03.11	
S/Nº	T920702000	SOPORTE BOMBA LAVADO	WASH PUMP SUPPORT	1								INTRODUCIDO 01.03.11	
	Q232030000	ARANDELA A5	FLAT WASHER A.5	2									
	Q012032000	TORNILLO EXAGONAL M5x15 A304	HEXAGONAL SCREW M.5x15	2									

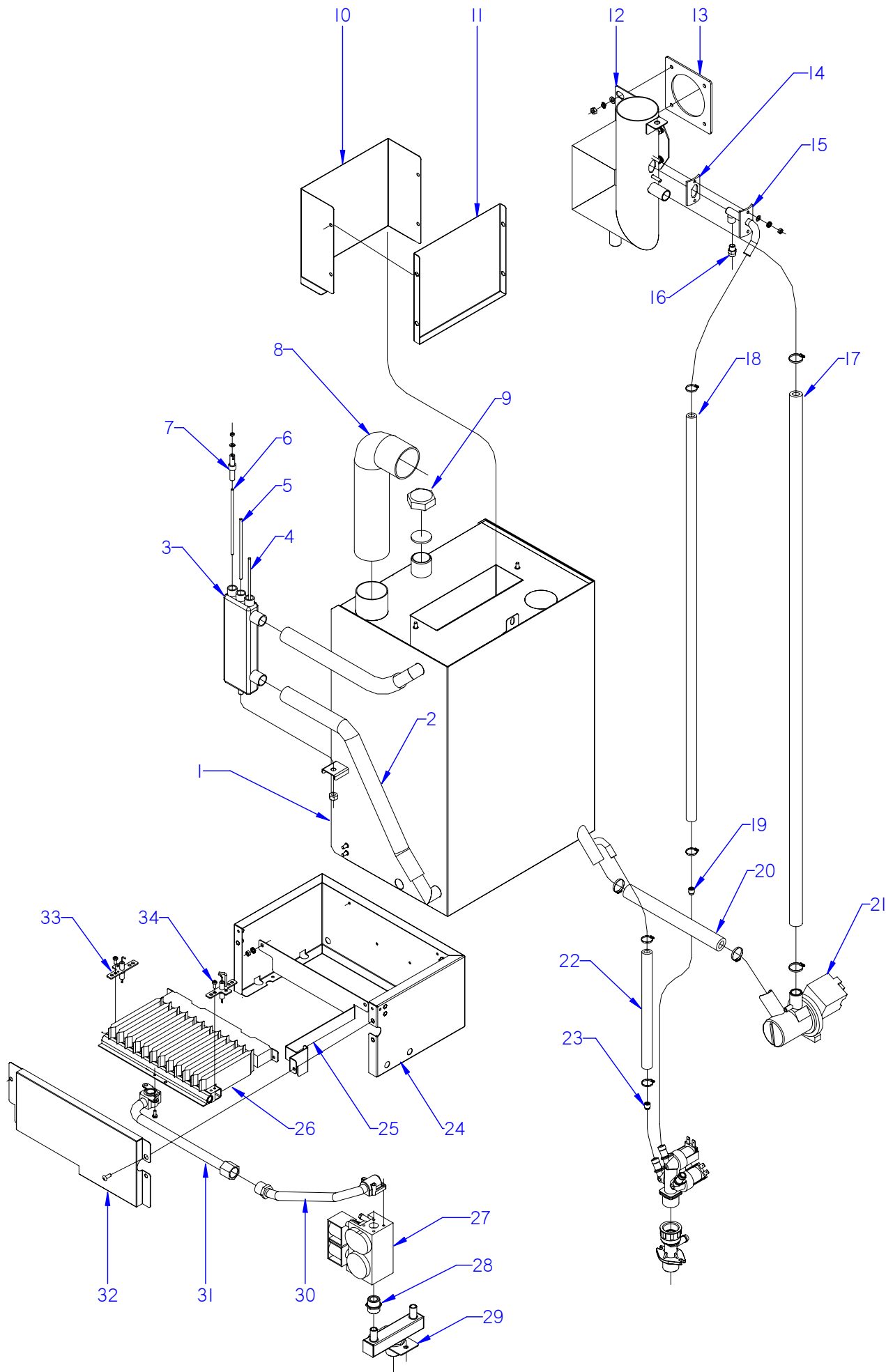

ITEM MARCADO EN COLOR = REPUESTO RECOMENDADO
 COLOURED ITEM = RECOMMENDED SPARE PART

N plano	Firma	Fecha	Aparato	CIRCUITO DE VAPOR / STEAM CIRCUIT	Lamina	Fagor Industrial S.Coop. FAGOR
C-2786	<i>(Signature)</i>	2011-01	HORNO VG-101 / VPG-101		9	Oñate

MOD.		HORNOS / OVEN		ZONA / ZONE		CIRCUITO DE VAPOR / STEAM CIRCUIT				PLANO DIAGRAM		C-2786	
ITEM	CODIGO CODE	DENOMINACION	NAME	VG-101	VPG-101							NOTAS	
1		KIT GENERADOR DE VAPOR 101	STEAM GENERATOR KIT 101	1	1								
1	T845006000	GENERADOR VAPOR 6-10-20/11G	STEAM GENERATOR 6-10-20/11G	1	1								
S/Nº	Z956104000	INYECTOR 1.1 A-15009 GN	1.1 A-15 009 INJECTOR GN	12	12								
2	3715900000	TUBO SILICONA ALTA Tª Ø26*18	HIGH SILICON PIPE Tª Ø26*18	2	2								
	Q901312000	ABRAZADERA ELASTI. Ø50,6-53,2	ELAST. CLAMP Ø50,6-53,2	4	4								
3	T325079000	BOTE DE NIVELES	LEVELS VESSEL	1	1								
	Q228051000	TUERCA EXAGONAL M8 PLASTICO	HEXAGONAL NUT M8 PLASTIC	1	1								
4	R345063000	ELECTRODO DE NIVEL BAJO	LOW LEVEL ELECTRODE	1	1								
5	R345060000	ELECTRODO DE NIVEL ALTO	HIGH LEVEL ELECTRODE	1	1								
6	R345064000	ELECTRODO DE MASA	EARTH ELECTRODE	1	1								
7	R345069000	GUIA AISLANTE	INSULATION GUIDE	3	3								
8	T722608000	TUBO FLEXIBLE Ø53X360	FLEXIBLE TUBE Ø53X360	1	1								
	Q881307000	ABRAZADERA 40*60	CLAMP 40*60	2	2								
9	R015010000	TUERCA TAPON 1"	PLUG NUT 1"	1	1								
	R015011000	ARANDELA Ø32	WASHER Ø32	1	1								
10	T845027000	POSTER. CHIMENEA GENERADOR	REAR FLUEPIPE GENERATOR	1	1								
11	T845028000	ANTER. CHIMENEA GENERADOR	FRONT FLUEPIPE GENERATOR	1	1								
	Q412002000	REMACHE TUBULAR Ø4x7,5	TUBULAR RIVET Ø4x7.5	12	12								
12	T845013000	RETORNO COMPLETO 1011	COMPLETE RETURN 1011	1	1								
	Q232040000	ARANDELA A6	WASHER A6	4	4								
	Q262040000	ARANDELA GROWER A6	WASHER GROWER A6	4	4								
	Q162040000	TUERCA EXAGONAL M6	HEXAGONAL NUT M6	4	4								
13	R725052000	JUNTA COLECT	COLLECTOR SEAL	1	1								
14	R725159000	JUNTA TUBO INYECTOR	INJECTOR PIPE SEAL	1	1								
15	T115112000	CONDUCCION DE VAHOS COMPL.	COMPL. VAPOUR DUCT	1	1								
16	T115086000	TOBERA 1/8"	NOZZLE 1/8	1	1								
	Q242030000	ARANDELA ABANICO A5 A.304	FAN WASHER A5 A.304	2	2								
	Q162030000	TUERCA EXAGONAL M5	HEXAGONAL NUT M5	2	2								
17	3715900000	TUBO SILICONA ALTA Tª Ø26*18	HIGH SILICON PIPE Tª Ø26*18	1	1								
	Q901311000	ABRAZADERA ELASTI. Ø26,7-28,1	ELAST. CLAMP Ø26.7-28.1	2	2								

MOD.		HORNOS / OVEN		ZONA / ZONE		CIRCUITO DE VAPOR / STEAM CIRCUIT				PLANO DIAGRAM		C-2786	
ITEM	CODIGO CODE	DENOMINACION	NAME	VG-101	VPG-101							NOTAS	
18	3702500000	TUBO GOMA NEGRA Ø17xØ11	BLACK RUBBER PIPE Ø17*11	1	1								
	Q901310000	ABRAZADERA ELASTI. Ø16,8-17,7	ELAST. CLAMP Ø16.8-17.7	2	2								
19	P443042000	REGULADOR 3L VERDE 254.023	REGULATOR 3L GREEN 254.023	1	1								
20	3715900000	TUBO SILICONA ALTA Tª Ø26*18	HIGH SILICON PIPE Tª Ø26*18	1	1								
	Q901311000	ABRAZADERA ELASTI. Ø26,7-28,1	ELAST. CLAMP Ø26.7-28.1	2	2								
21	Z220901000	BOMBA DESAGUE 30W	DRAINAGE PUMP 30W	1	1								
21	Z223501000	BOMBA DE DESAGUE 30W 60HZ	DRAINAGE PUMP 30W 60HZ	1	1								
22	3676900000	TUBO GOMA NEGRA Ø17xØ10	BLACK RUBBER PIPE Ø17*10	1	1								
	Q901310000	ABRAZADERA ELASTI. Ø16,8-17,7	ELAST. CLAMP Ø16.8-17.7	2	2								
23	Z601156000	REGULADOR 8L RO. 254.034	REGULATOR 8L RED 254.034	1	1								
24	T305704000	CAJA QUEMADOR	BURNER BOX	1	1								
25	T305706000	ESCUADRA AMARRE QUEMADOR	TIE BRACKET BURNER	1	1								
26	Z955801000	QUEMADOR F0000161	BURNER F0000161	1	1								
	Q032021000	TORNILLO ALOMADO M4X10	CURVED SCREW M4X10	2	2								
	Q242020000	ARANDELA ABANICO A4	FAN WASHER A4	2	2								
	Q162020000	TUERCA EXAGONAL M4	HEXAGONAL NUT M4	2	2								
27	Z952201000	VALVULA SIT 830.034 50 Hz	VALVE SIT 830.034 50 Hz	1	1								
27	Z953501000	VALVULA SIT 830.062 60 Hz	VALVE SIT 830.062 60 Hz	1	1								
	R723016000	JUNTA CON. 830 960.108	SEAL CON. 830 960.108	1	1								
28	S205023000	MANGUITO DOBLE 1/2	DOUBLE SLEEVE 1/2	1	1								
	Q221334000	TUERCA 1/2"	NUT 1/2"	2	2								
	U055043000	BICONO Ø12	BICONE Ø12	2	2								
29	T845019000	ENTRADA DE GAS COMP HGV P	COMP GAS INPUT HGV P	1	1								
	Q232040000	ARANDELA A6	WASHER A6	2	2								
	Q242040000	ARANDELA ABANICO A6 A.304	FAN WASHER A6 A.304	2	2								
	Q012042000	TORNILLO EXAGONAL M6X15	HEXAGONAL BOLT M6x15	2	2								
30	T305090000	TUBO DE GAS FLEXIBLE 300-90º	FLEXIBLE GAS PIPE 300-90 º	1	1								
31	T305718500	ACOPLADOR COMPL. PINTADO	PAINTED COMPL. COUPLER	1	1								
	Z955807000	JUNTA CORCHO	CORK SEAL	1	1								
32	T305705000	TAPA CAJA	BOX COVER	1	1								

ITEM MARCADO EN COLOR = REPUESTO RECOMENDADO
 COLOURED ITEM = RECOMMENDED SPARE PART

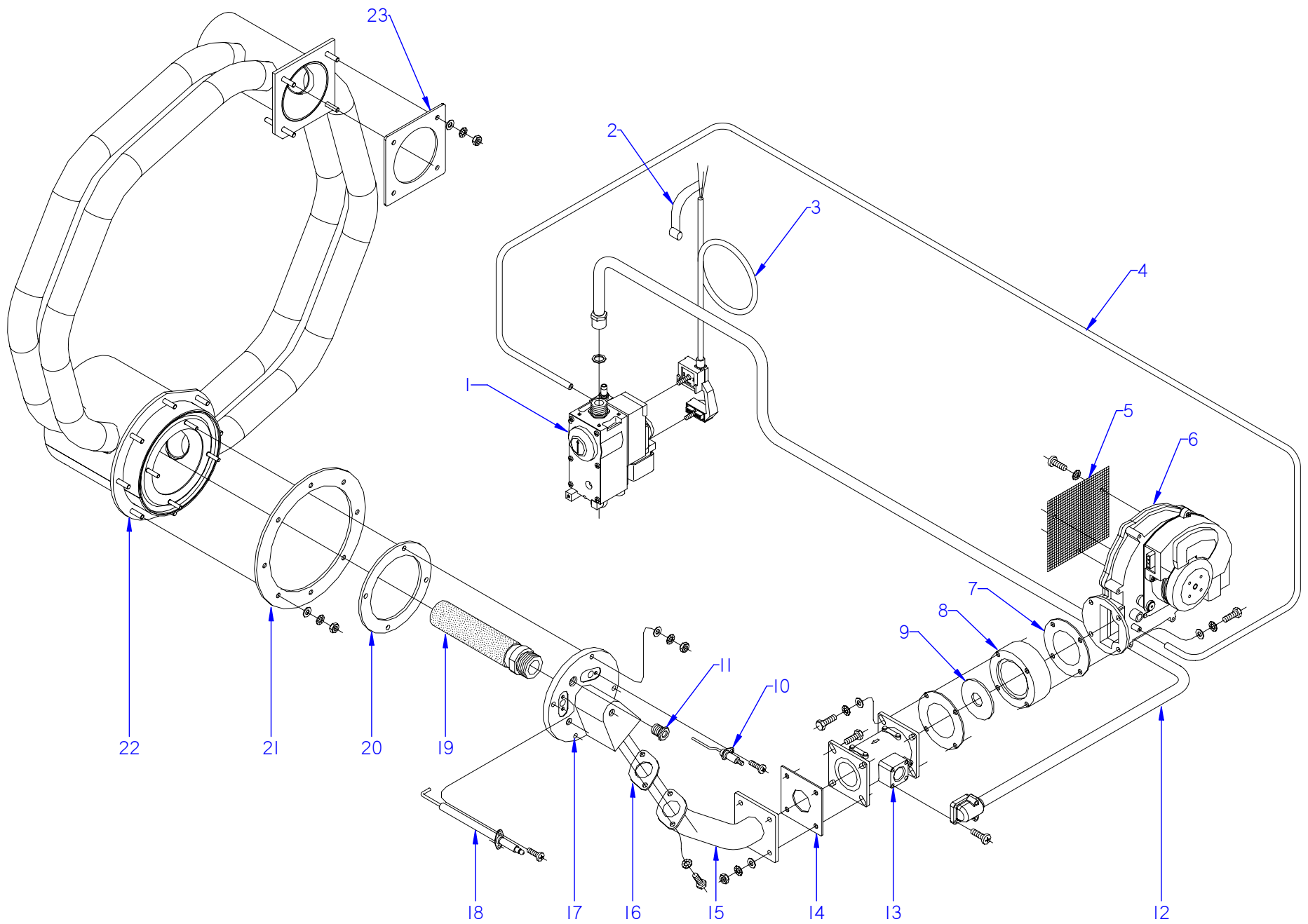

MOD.		HORNOS / OVEN		ZONA / ZONE		PARTE FUNCIONAL GAS FUNCTIONAL PART GAS				PLANO DIAGRAM		C-2787	
ITEM	CODIGO CODE	DENOMINACION	NAME	COG-061	COG-101	VG-101	VPG-101						NOTAS
1	T085010000	VALVULA REGUL. BP 50 Hz 6/11	CONTROL VALVE BP 50 Hz 6/11	1	-	-	-						
1	T085011000	VALVULA REGUL. GN 50 Hz 6/11	CONTROL VALVE GN 50 Hz 6/11	1	-	-	-						
1	T085016000	VALVULA REGUL. BP 60 Hz 6/11	CONTROL VALVE BP 60 Hz 6/11	1	-	-	-						
1	T085017000	VALVULA REGUL. GN 60 Hz 6/11	CONTROL VALVE GN 60 Hz 6/11	1	-	-	-						
1	T115097000	VALVULA REGUL. BP 50 Hz 10/11	CONTROL VALVE BP 50 Hz 10/11	-	1	1	1						
1	T115098000	VALVULA REGUL. GN 50 Hz 10/11	CONTROL VALVE GN 50 Hz 10/11	-	1	1	1						
1	T115100000	VALVULA REGUL. BP 60 Hz 10/11	CONTROL VALVE BP 60 Hz 10/11	-	1	1	-						
1	T115101000	VALVULA REGUL. GN 60 Hz 10/11	CONTROL VALVE GN 60 Hz 10/11	-	1	1	-						
S/Nº	R723013000	CONEXION VALVULA 960.107	VALVE CONNECTION 960,107	-	-	1	1						INTRODUCIDO 15.01.11
	R723016000	JUNTA CONEXION 830 960.108	CONNECTI. BOARD 830 960 108	-	-	1	1						INTRODUCIDO 15.01.11
2	Z233012000	CONDENSADOR ANTIPARASITARIO	ANTIPARASITIC CONDENSOR	1	1	3	3						
3	T085012000	CONECTOR VALVULA HONEYW.	HONEYW. VALVE CONNECTOR	1	1	1	1						
4	3702500000	TUBO GOMA NEGRO Ø 7*11	BLACK RUBBER PIPE Ø 7*11	1	1	1	1						
5	T115095000	MALLA VENTILADOR	FAN GRILLE	1	1	1	1						
	Q032021000	TORNILLO ALOMADO M4X10	CURVED SCREW M4X10	4	4	4	4						
	Q242020000	ARANDELA ABANICO A4	FAN WASHER A4	4	4	4	4						
6	T083000000	VENTILADOR E.B.M.-RG130	FAN E.B.M.-RG130	1	1	1	1						
7	T115081000	JUNTA ACOPLAMIENT. SOPLANTE	BLOWER COUPLING SEAL	2	2	2	2						
8	T115076000	ACOPLAMIEN. VENTILADOR MIXER	MIXER FAN COUPLING	1	1	1	1						
9	T085018000	ARANDELA VENTILAD. MIXER Ø14	MIXER FAN WASHER Ø14	1	-	-	-						
9	T845703000	ARANDELA VENTILAD. MIXER Ø19	MIXER FAN WASHER Ø19	-	1	1	1						
10	T115712000	ELECTRODO DETECCI. 6/101/102	DETECTION ELECTRODE 6/101/102	1	1	1	1						
	Q153021000	TORNILLO ALOMADO M4 X 10	CURVED SCREW M4 X 10	2	2	2	2						
11	R725015000	VISOR DE ENCENDIDO	IGNITION WINDOW	1	1	1	1						
	R725063000	CRISTAL DE VISOR	WINDOW GLASS	1	1	1	1						
12	T305092000	TUBO DE GAS FLEXIBLE 1300-90º	FLEXIBLE GAS PIPE 300-90 °	1	1	1	1						
13	T085007000	MIXER SIT 25KW	MIXER SIT 25KW	1	-	-	-						
13	T115075000	MIXER SIT 35KW	MIXER SIT 35KW	-	1	1	1						
14	T115079000	JUNTA MIXER	MIXER SEAL	1	1	1	1						
15	T115077000	CONDUCTO GAS TAPA PRINCIPAL	MAIN COVER GAS PIPE	1	1	1	1						

MOD.		HORNOS / OVEN		ZONA / ZONE		PARTE FUNCIONAL GAS FUNCTIONAL PART GAS				PLANO DIAGRAM		C-2787	
ITEM	CODIGO CODE	DENOMINACION	NAME	COG-061	COG-101	VG-101	VPG-101						NOTAS
16	T095021000	JUNTA CONDUCTO	PIPE SEAL	1	1	1	1						
	Q012032000	TORNILLO EXAGONAL M5X15 A304	HEXAGONAL BOLT M5x15 A304	2	2	2	2						
	Q242030000	ARANDELA ABANICO A5 A.304	FAN WASHER A5 A.304	2	2	2	2						
17	T085715000	TAPA PRINCIPAL 6/11	MAIN COVER 6/11	1	-	-	-						
17	T115782000	TAPA PRINCIPAL	MAIN COVER	-	1	1	1						
	Q242030000	ARANDELA ABANICO A5 A.304	FAN WASHER A5 A.304	4	4	4	4						
	Q163030000	TUERCA EXAGONAL M5 LATON	HEXAGONAL NUT M5 BRASS	4	4	4	4						
18	T085714000	ELECTRODO IGNICION 6/11	IGNITION ELECTRODE 6/11	1	-	-	-						
18	T115781000	ELECTRODO IGNICION 10/11-10/21	IGNITION ELECTRODE 10/11-10/21	-	1	1	1						
	Q153021000	TORNILLO ALOMADO M4 X 10	CURVED SCREW M4 X 10	1	1	1	1						
19	T085710000	QUEMADOR FURIGAS 6/11	BURNER FURIGAS 6/11	1	-	-	-						
19	T115710000	QUEMADOR FURIGAS 20/11	BURNER FURIGAS 20/11	-	1	1	1						
20	T075013000	JUNTA DE TAPA PRINCIPAL	MAIN COVER SEAL	1	-	-	-						
20	R725055000	JUNTA DE TAPA PRINCIPAL	MAIN COVER SEAL	-	1	1	1						
21	T075014000	JUNTA CAMARA COMBUS. 6/11	FUEL CHAMBER SEAL 6/11	1	-	-	-						
21	R725051000	JUNTA CAMARA COMBUS. 101/102	FUEL CHAMBER SEAL 101/102	-	1	1	1						
22	T935701000	CAMARA COMBUSTION 061	COMBUSTION CHAMBER 061	1	-	-	-						
22	T015700000	CAMARA COMBUSTION 10-11	COMBUSTION CHAMBER 10-11	-	1	-	-						
22	R725701000	INTERCAMBIADOR 10/11/21	HEAT EXCHANGER 10/11/21	-	-	1	1						
	Q232040000	ARANDELA A6	WASHER A6	8	8	8	8						
	Q262040000	ARANDELA GROW. A6 A.304	WASHER GROW. A6 A.304	8	8	8	8						
	Q163040000	TUERCA EXAGONAL M6 LATON	HEXAGONAL NUT M6 BRASS	8	8	8	8						
23	R725052000	JUNTA COLECTOR	MANIFOLD SEAL	-	-	1	1						
	Q232040000	ARANDELA A6	WASHER A6	-	-	4	4						
	Q242040000	ARANDELA ABANICO A6	FAN WASHER A6	-	-	4	4						
	Q162040000	TUERCA EXAGONAL M6	HEXAGONAL NUT M6	-	-	4	4						

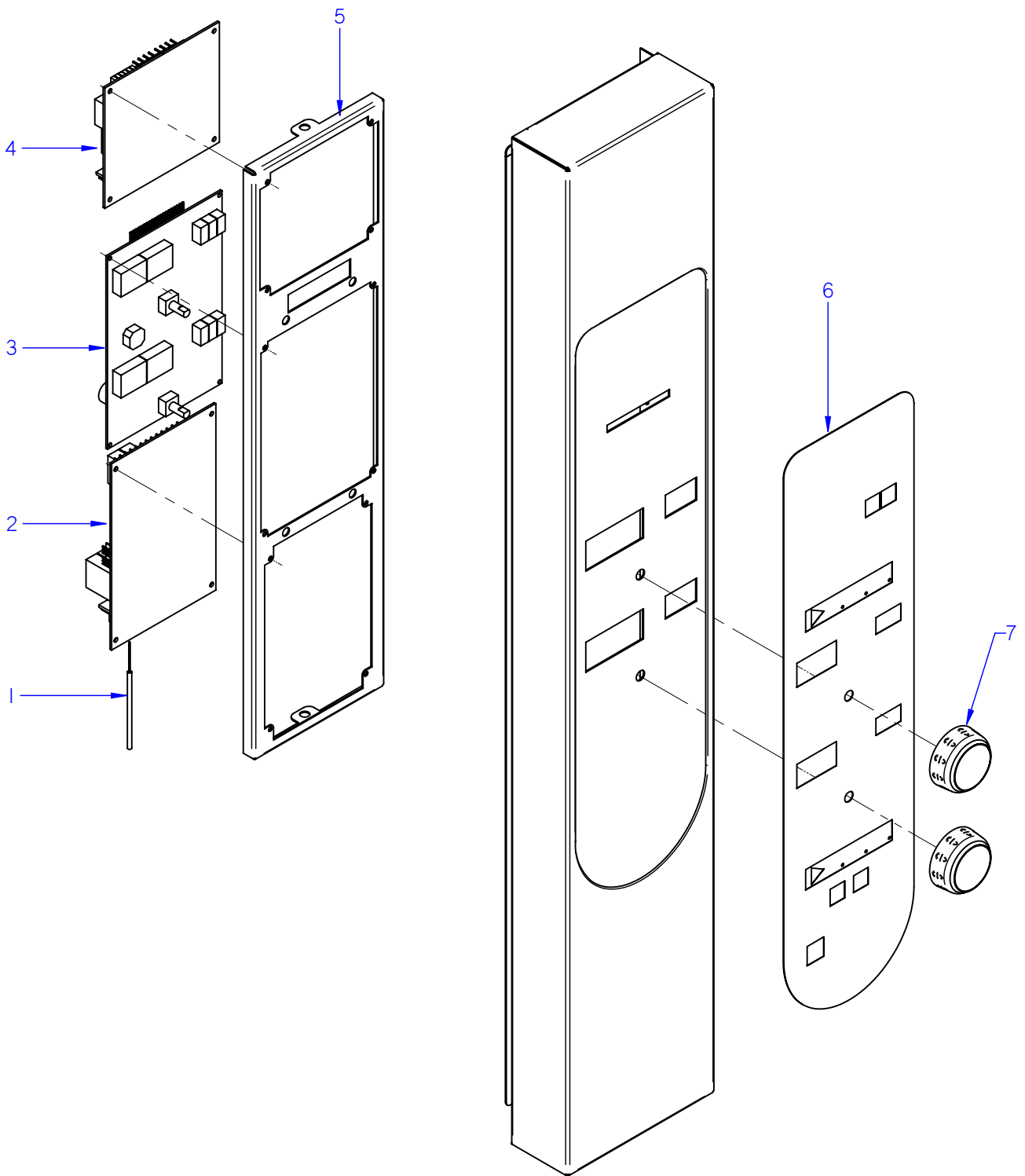

ITEM MARCADO EN COLOR = REPUESTO RECOMENDADO
 COLOURED ITEM = RECOMMENDED SPARE PART

N plano	Firma	Fecha	Aparato CONJUNTO ELECTR. PORTAMANDOS / CONTROL HOLDER ELECTRIC UNIT	Lamina	Fagor Industrial S.Coop. FAGOR
C-2788	<i>(Signature)</i>	2011-01	HORNOS COG-061 / 101	11	Oñate

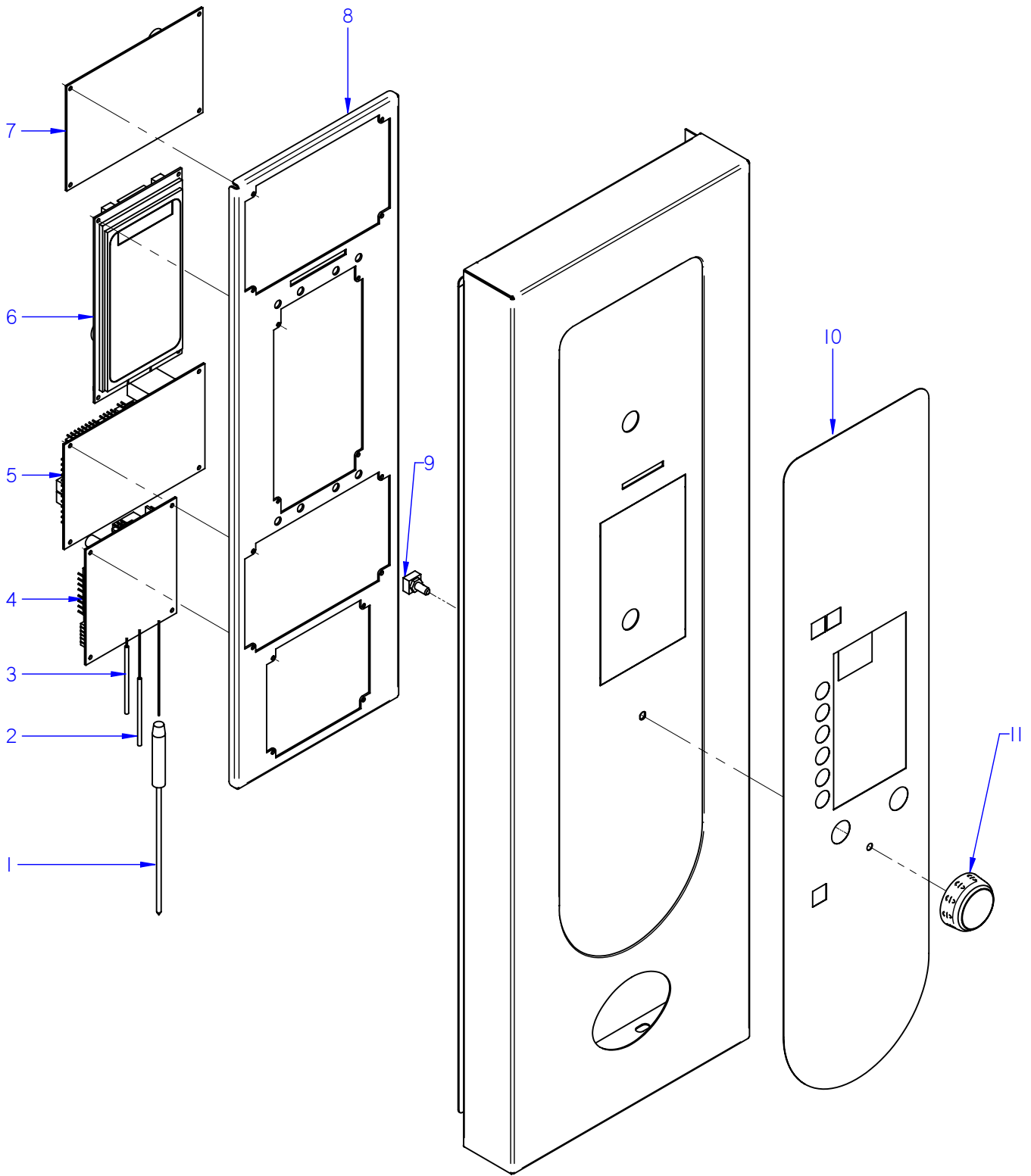

ITEM MARCADO EN COLOR = REPUESTO RECOMENDADO
 COLOURED ITEM = RECOMMENDED SPARE PART

N plano	Firma	Fecha	Aparato	CONJUNTO ELECTRICO PORTAMANDOS	Lamina	Fagor Industrial S.Coop. FAGOR
C-2789	<i>[Signature]</i>	2011-01	HORNOS VG-101		12	Oñate

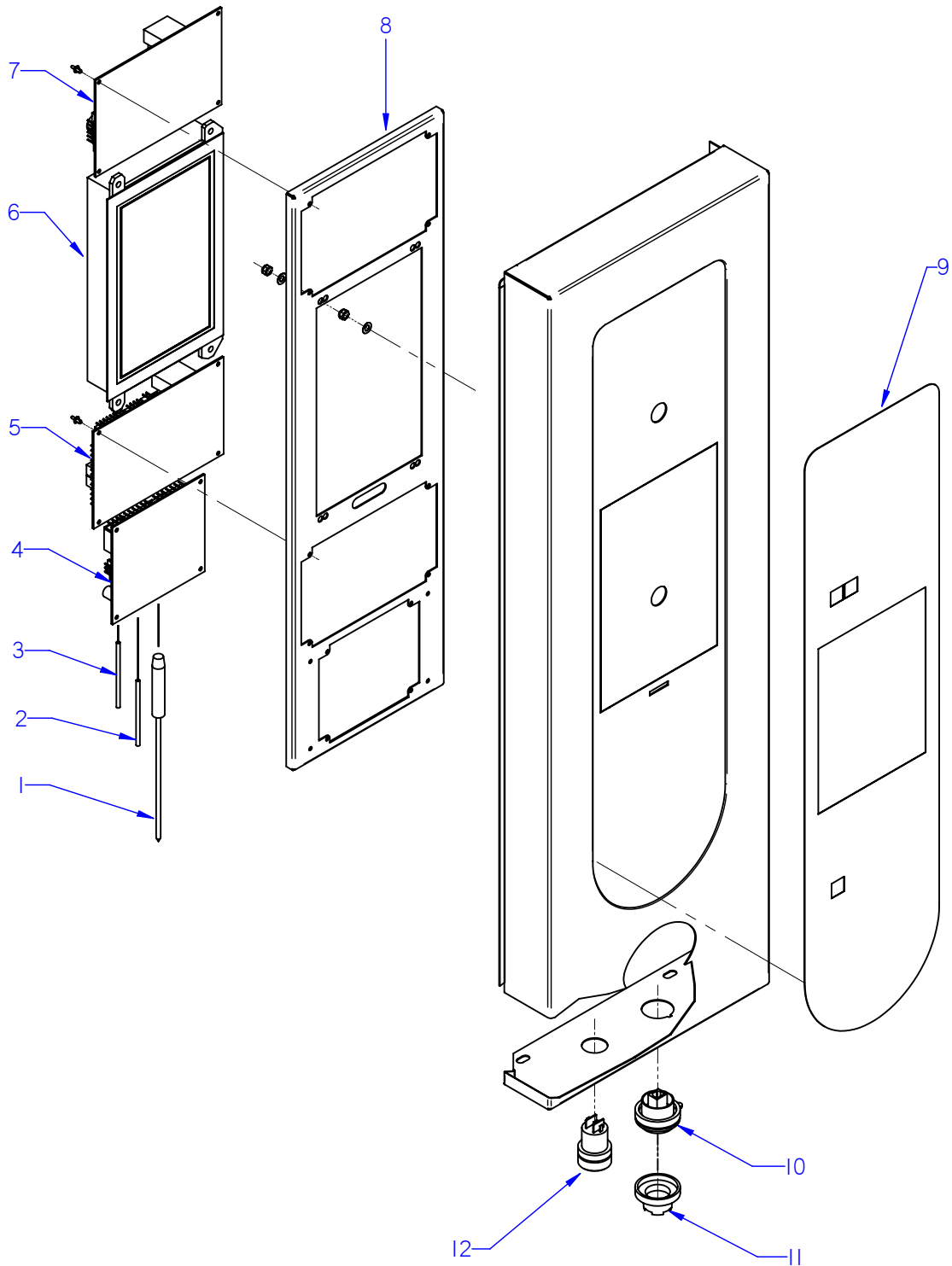

ITEM MARCADO EN COLOR = REPUESTO RECOMENDADO
 COLOURED ITEM = RECOMMENDED SPARE PART

N plano	Firma	Fecha	Aparato	CONJUNTO ELECTRICO PORTAMANDOS / CONTROL HOLDER ELECTRIC	Lamina	Fagor Industrial S.Coop. FAGOR
C-2790	<i>name (benj)</i>	2011-01		HORNOS VPG-101	13	Oñate

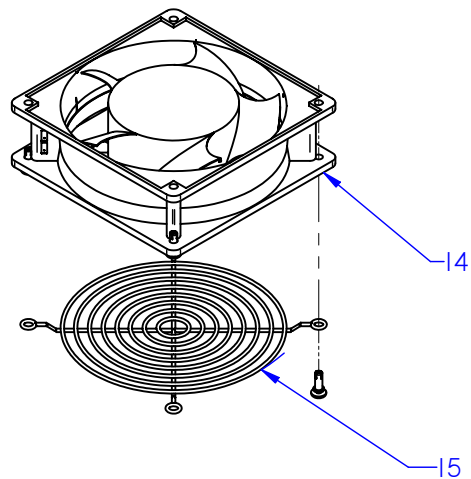
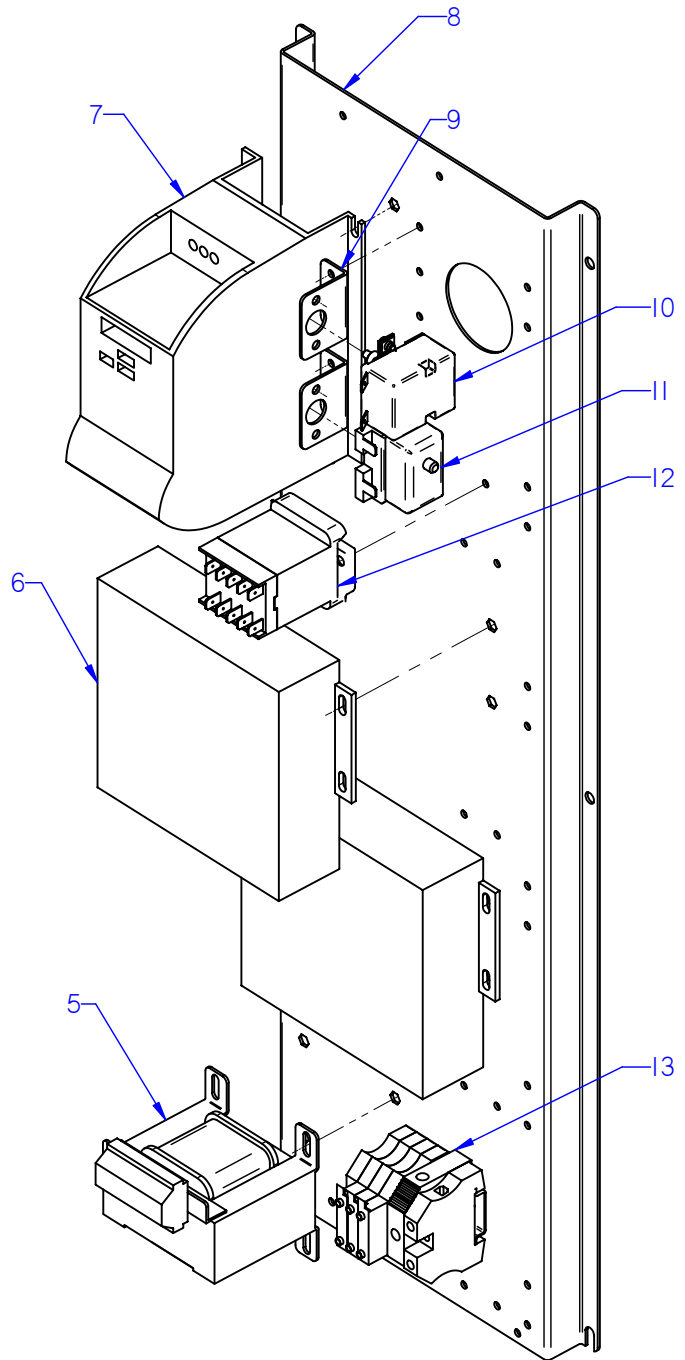
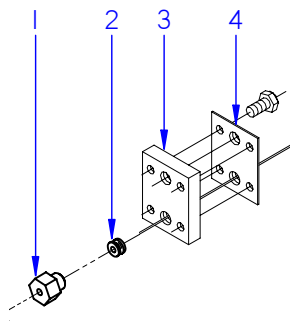

ITEM MARCADO EN COLOR = REPUESTO RECOMENDADO
COLOURED ITEM = RECOMMENDED SPARE PART

N plano	Firma	Fecha	Aparato	CUADRO ELECTRICO / ELECTRIC PANEL	Lamina	Fagor Industrial S.Coop. FAGOR
C-2791	<i>name Benja</i>	2011-01	HORNOS COG / VG / VPG-061/101	14	Oñate	

MOD.		HORNOS / OVEN		ZONA / ZONE		CUADRO ELECTRICO / ELECTRIC PANEL		PLANO DIAGRAM		C-2791	
ITEM	CODIGO CODE	DENOMINACION	NAME	COG-061	COG-101	VG-101	VPG-101				NOTAS
1	R662629000	RACORD CIERRE SONDA	PROBE CLOSING ADAPTOR	2	2	2	2				
S/Nº	R662662000	JUNTA CIERRE BULBO LIMITADOR	BULB LIMITER CLOSING SEAL	1	1	1	1				
2	R662652000	BICONO CIERRE SONDA	PROBE CLOSING BICONE	1	1	1	1				
3	R662659000	APOYO RACORD SONDA	PROBE CONNECTION SUPPORT	1	1	1	1				
4	R692811000	JUNTA PASAMUROS DOBLE	DOUBLE FEEDTHROUGH GASKE	1	1	1	1				
	Q232020000	ARANDELA A4	WASHER A.4	4	4	4	4				
	Q012021000	TORNILLO EXAGONAL M4X10	HEXAGONAL SCREW M.4X10	4	4	4	4				
5	R503005000	TRANSFORMADOR 230/12-0-12,0-1	TRANSFORMER 230/12-0-12,0-1	1	1	1	—				
5	T853002000	TRANSFORMADOR 12-0-12-0,24-0	TRANSFORMER 12-0-12-0,24-0	—	—	—	1				
6	Z953004000	CONTROL COMBUSTION	COMBUSTION CONTROL	1	1	2	2				
7	T323037000	VARIADOR FRECUENCIA SIE 0,37	FREQUENCY VARIATOR SIE 0.37	1	1	1	1				
	Q242020000	ARANDELA ABANICO A4 A.304	FAN SHAPED WASHER A.4	12	12	12	12				
	Q032021000	TORNILLO ALOMADO M4X10	CURVED SCREW M.4x10	12	12	12	12				
8	T933004000	CHAPA CUADRO ELECT. COG-061	SQUARE PLATE ELEC. COG-061	1	1	—	—				
8	T843009000	CHAPA CUADRO ELECTRI VGP 101	SQUARE PLATE ELEC. VGP 101	—	—	1	1				
9	R343039000	SOPORTE TERMOS VAPOR	THERMOSTAT SUPPORT	1	1	2	2				
	Q412002000	REMACHE AVINOX Ø4x10MM	TUBULAR RIVET 4x7,5	2	2	4	4				
10	T303009000	TERMOSTATO LIMITADOR	THERMOSTAT LIMITER	1	1	1	1				
	Z953041000	TUERCA M.10x1 EGO 00.00600.075	NUT M.10x1 EGO 00.00600.075	1	1	2	2				
11	Z953035000	TERMOSTATO LIMITADOR AVISO	LIMITER THERMOSTAT WARNING	—	—	1	1				
12	Z213007000	CONTACTOR 230V.50-60	230V.50-60 CONTACTOR	1	1	1	1				
13	P453026000	BORNE TIER 10 WPE-10103.O	10 WPE-10103.O EARTH TERM.	1	1	1	1				
	R073005000	BORNA PORTAFUSIBLES	FUSE HOLDER TERMINAL	3	3	3	3				
	Z263303000	TOPE FINAL	END BUFFER	1	1	1	1				
14	Z103066000	VENTILADOR 230V.50-60HZ	FAN 230V 50/60HZ	1	1	3	3				
15	T113015000	PROTECCION VENTILADOR	FAN PROTECTION	1	2	2	2				
	Q418021000	REMACHE PLASTICO Ø4 L7,5-8,5	PLASTIC RIVET Ø4 L7,5-8,5	4	4	8	8				
S/Nº	T303045000	CONECTOR PASO 3,96 MM 8 VIAS	STEP CONNECTOR	1	1	1	1				

VPG 10 1, VPG 20 1
 VG 10 1, VG 20 1
 COG 06 1, COG 10 1, COG 20 1

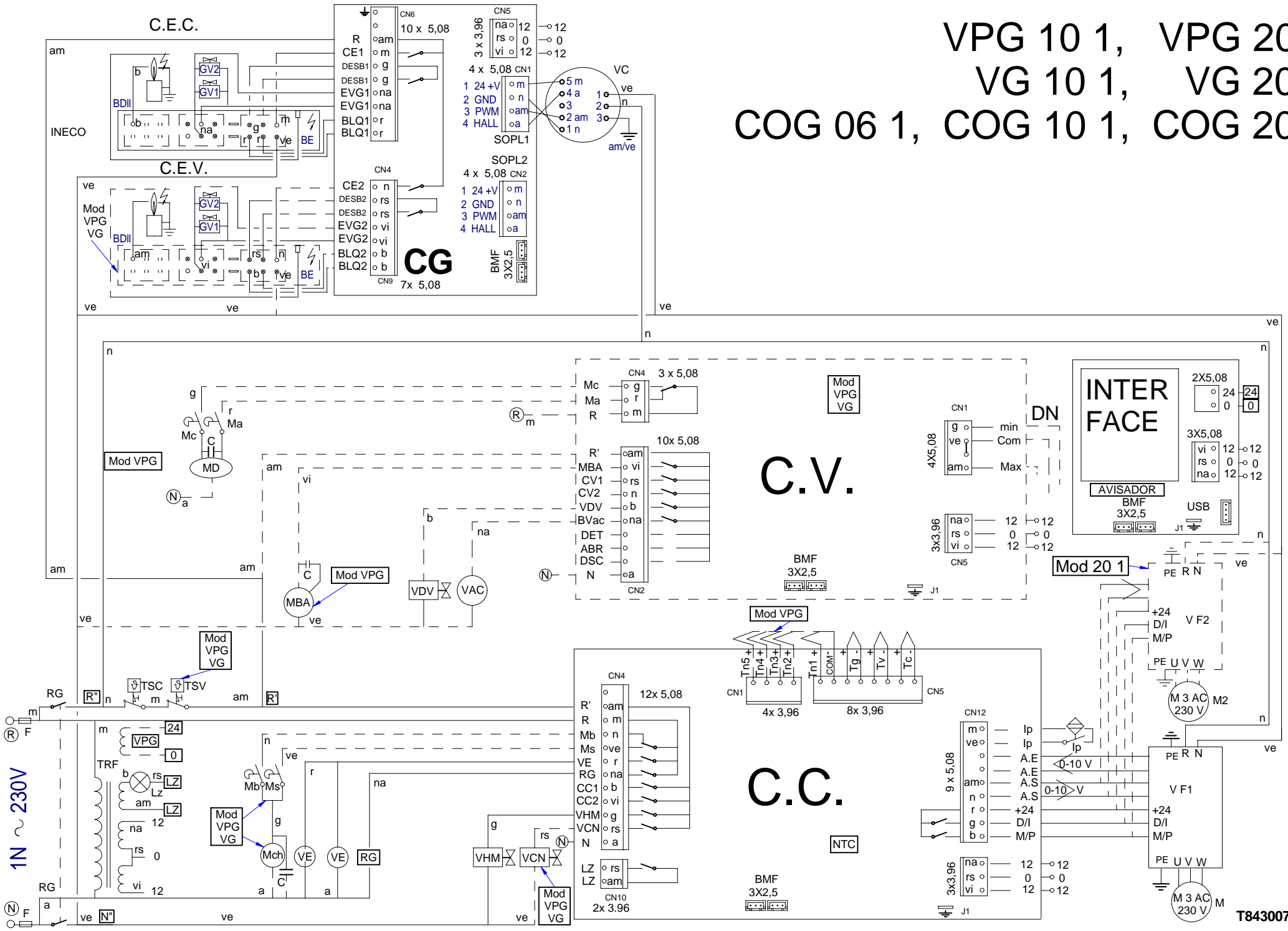

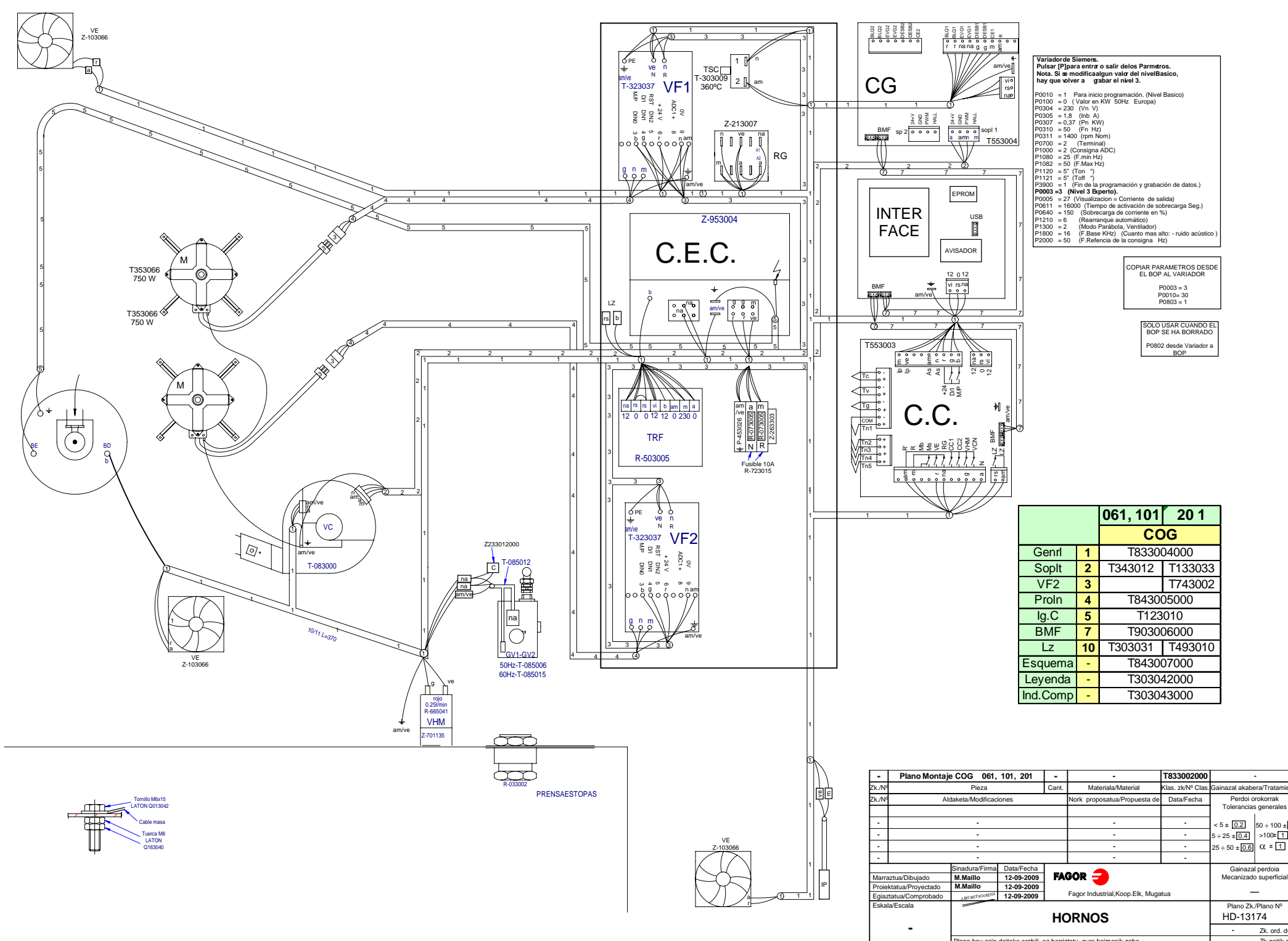

Variadoro Siemens.
Pulsar [P] para entrar o salir de los Parmetros.
Nota. Si se modifica algun valor del nivel Basico, hay que volver a grabar el nivel 3.

P0010 = 1 Para inicio programación. (Nivel Basico)
P0100 = 0 (Valor en KW 50Hz Europa)
P0304 = 230 (Vn Vv)
P0305 = 1.8 (Inb A)
P0307 = 0.37 (Pn KW)
P0310 = 50 (Fn Hz)
P0311 = 1400 (rpm Nom)
P0700 = 2 (Terminal)
P1000 = 2 (Consigna ADC)
P1080 = 25 (F.min Hz)
P1082 = 50 (F.Max Hz)
P1120 = 5 (Ton %)
P1121 = 5 (Toff %)
P3800 = 1 (Fin de la programación y grabación de datos.)

P0003 = 3 (Nivel 3 Experto).
P0005 = 27 (Visualización = Corriente de salida)
P0611 = 16000 (Tiempo de activación de sobrecarga Seg.)
P0640 = 150 (Sobrecarga de corriente en %)
P1210 = 6 (Rearranque automático)
P1300 = 2 (Modo Parábola, Ventilador)
P1800 = 16 (F.Base KHz) (Cuanto mas alto: - ruido acústico)
P2000 = 50 (F.Referencia de la consigna Hz)

COPIAR PARAMETROS DESDE EL BOP AL VARIADOR

P0003 = 3
P0010 = 30
P0803 = 1

SOLO USAR CUANDO EL BOP SE HA BORRADO

P0802 desde Variador a BOP

		061, 101	20 1
		COG	
Genrl	1	T833004000	
Soplt	2	T343012	T133033
VF2	3	T743002	
ProIn	4	T843005000	
Ig.C	5	T123010	
BMF	7	T903006000	
Lz	10	T303031	T493010
Esquema	-	T843007000	
Leyenda	-	T303042000	
Ind.Comp	-	T303043000	

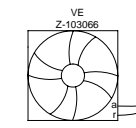
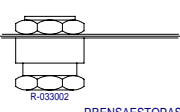
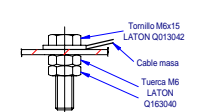

Plano Montaje COG 061, 101, 201		T833002000				
Zk./Nº	Pieza	Carnt.	Materia/Material	Klas. zk/Nº Clas.	Gainazal akabera/Tratamiento	
Zk./Nº	Aldaketa/Modificaciones	Nork proposatua/Propuesta de		Data/Fecha	Perdoi orokerrak	
					Tolerancias generales	
					< 5 ± [0.2]	50 - 100 ± [0.8]
					5 - 25 ± [0.4]	> 100 ± [1]
					25 - 50 ± [0.8]	α ± [1]
Marratzua/Dibujado	Sinadura/Firma	Data/Fecha	FAGOR			
Proiektatua/Proyettato	M.Maillio	12-09-2009	Fagor Industrial, Koop. Etk. Mugatua			
Egiaztatua/Comprobado	M.Maillio	12-09-2009	Gainazal perdoia			
Eskala/Escala			HORNOS		Mecanizado superficial	
					Plano Zk./Plano Nº	
					HD-13174	
					- Zk. ord. du	
					- Zk.gaitik ord.	

Plano hau ezin daiteke erabili, ez beziritzatu, gure baimenik gabe.

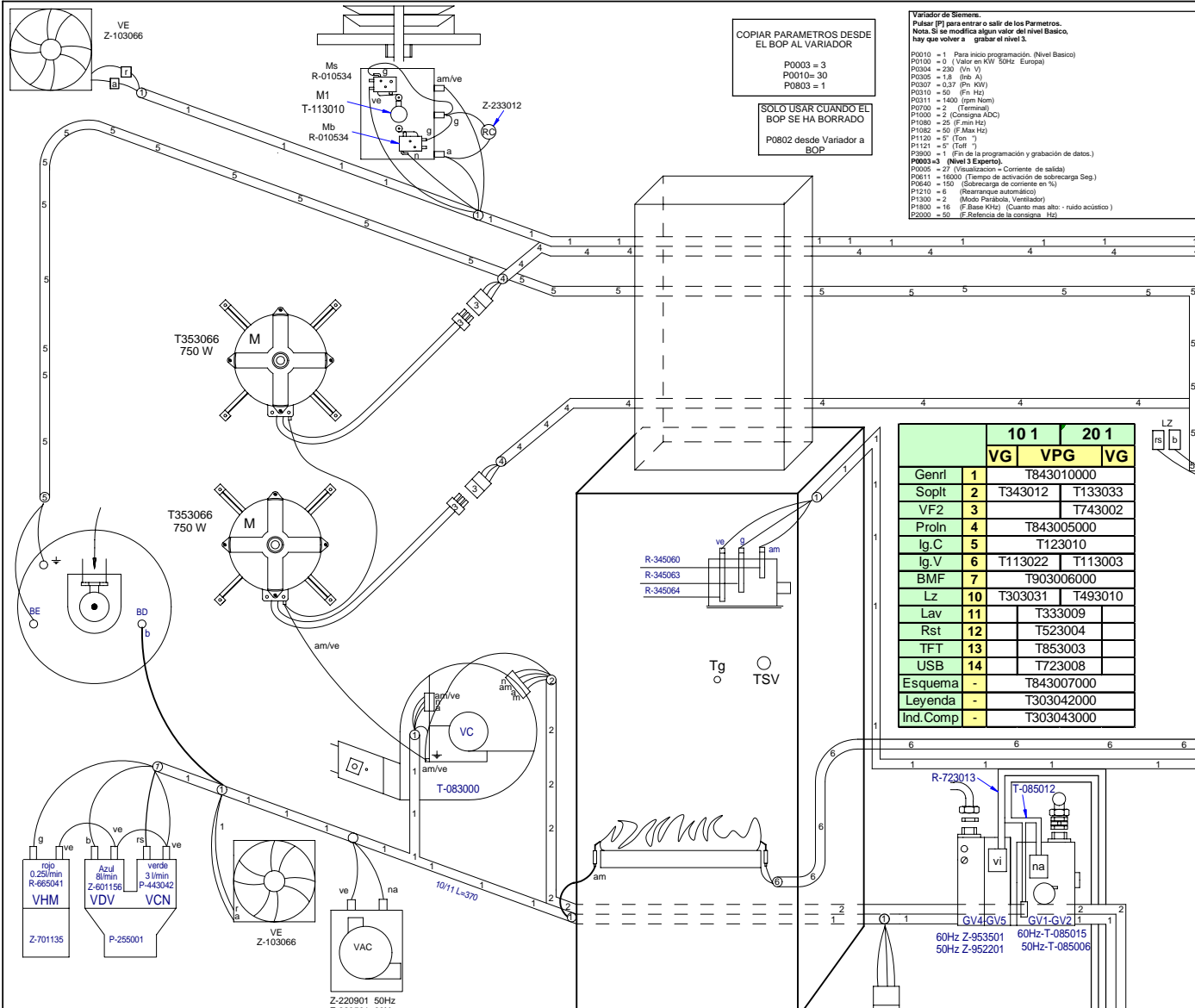

COPIAR PARAMETROS DESDE EL BOP AL VARIADOR

P0003 = 3
P0010 = 30
P0803 = 1

SOLO USAR CUANDO EL BOP SE HA BORRADO

P0802 desde Variador a BOP

Variador de Siemens.
Pulsar [P] para entrar a salir de los Parametros.
Nota: Si se modifica algun valor del nivel Basico, hay que volver a grabar el nivel 3.

P0010 = 1 Para inicio programación (Nivel Basico)
P0100 = 0 (Valor en VV: Sónde, Europa)
P0304 = 230 (Vn V)
P0305 = 1.8 (Ibn A)
P0307 = 0.37 (Pn kW)
P0310 = 50 (Fm Hz)
P0311 = 1400 (rpm Npm)
P0700 = 2 Terminal
P1000 = 2 (Configuración ADC)
P1080 = 25 (Fm Hz)
P1082 = 50 (Fm Hz)
P1120 = 5 (Ton °)
P1121 = 5 (Ton °)
P3800 = 1 (Fin de la programación y grabación de datos.)

P0003-3 (Nivel 3 Experto).
P0006 = 27 (Visualización - Corriente de salida)
P0611 = 16000 (Tiempo de activación de sobrecarga Seg.)
P0640 = 150 (Sobrecarga de corriente en %)
P1210 = 6 (Rearranque automático)
P1300 = 2 (Modo Parada, Ventilador)
P1800 = 16 (F-Base KHz) (Cuanto mas alto - ruido acústico)
P1121 = 5 (Ton °)
P2000 = 50 (Referencia de la consigna - Hz)

	10 1	20 1
	VG	VPG
Genrl	1	T843010000
Soptl	2	T343012 T133033
VF2	3	T743002
Proln	4	T843005000
Ig.C	5	T123010
Ig.V	6	T113022 T113003
BMF	7	T903006000
Lz	10	T303031 T493010
Lav	11	T333009
Rst	12	T523004
TFT	13	T853003
USB	14	T723008
Esquema	-	T843007000
Leyenda	-	T303042000
Ind.Comp	-	T303043000

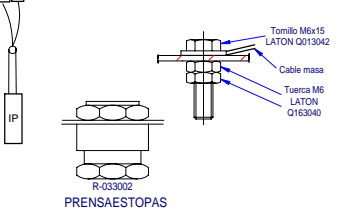
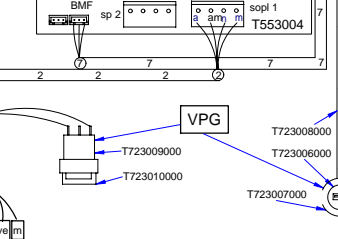
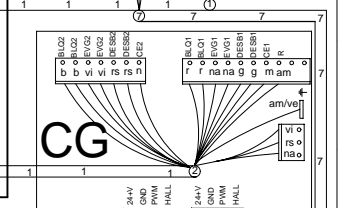
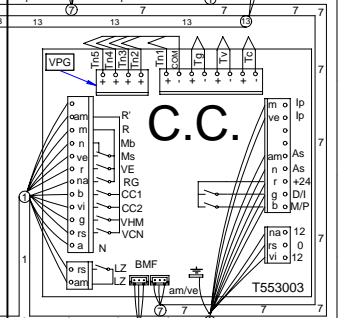
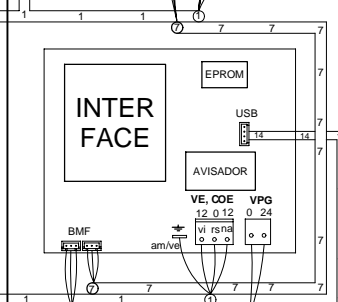
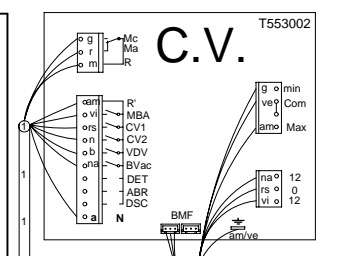
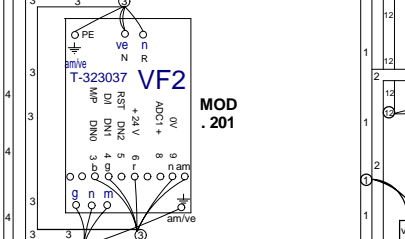
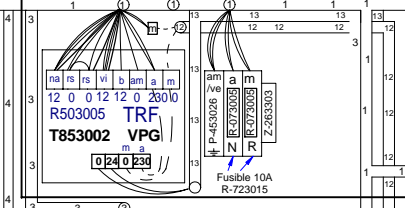
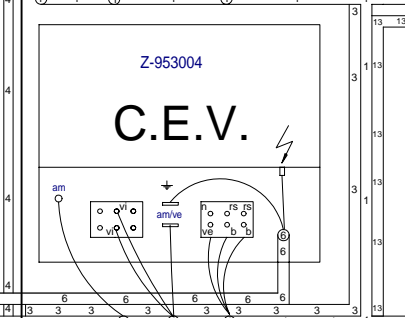
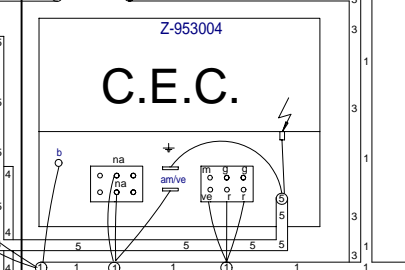
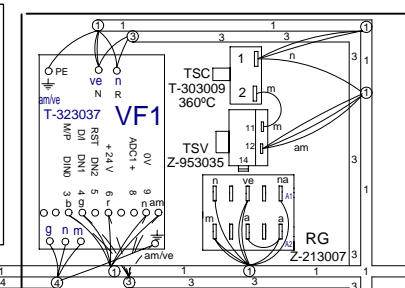

Plano Montaje VG 10 1			T843008000	
Zk/Nº	Pieza	Cant.	Materia/Material	Klas. zk/Nº Clas.
Zk/Nº	Aldaketa/Modificaciones		Nork proposatua/Propuesta de	Data/Fecha
-	-	-	-	Perdi orokorrak
-	-	-	-	Tolerancias generales
-	-	-	-	< 5 ± 0.2
-	-	-	-	50 ± 100 ± 0.8
-	-	-	-	5 ± 25 ± 0.4
-	-	-	-	> 100 ± 1
-	-	-	-	25 ± 50 ± 0.8
-	-	-	-	α ± 1
Marratza/Dibujado	Sinadura/Firma	Data/Fecha	Gainazal perdioa	
M.Maillio	M.Maillio	12-10-2009	Mecanizado superficial	
Proiektatua/Proyectado	M.Maillio	12-10-2009	-	
Egiaztatua/Comprobado		12-10-2009	-	
Eskala/Escala			Plano Zk/Plano Nº	
-			HD-13176	
-			- Zk. ord. ud.	
-			- Zk.gatik ord.	

HORNOS

Fagor Industrial, Koop. Elk. Mugatua

Plano hau ezin dateke erabili, ez bezirratu, gure baitimen gabe.

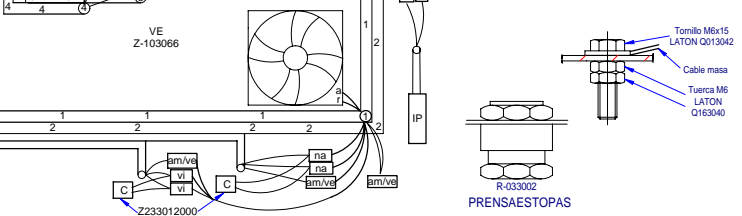
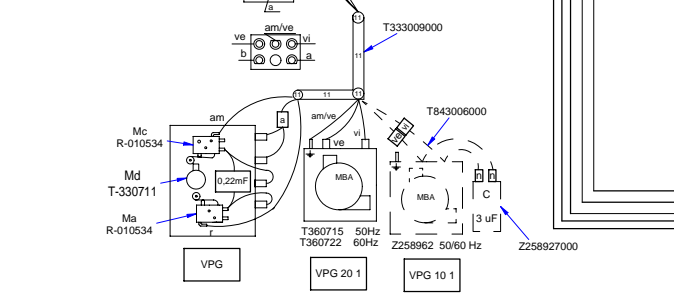

	ESPAÑOL	FRANÇAIS	ENGLISH	DEUTSCH	ITALIANO
BEC	Bujía Encendido Cámara	Chamber Allumage Chambre	Chamber Spark Plug	Zündkerze Einschalten Garraum	Candela di Accensione Camera
BEV	Bujía Encendido Caldera	Bougie Allumage Chaudière	Boiler Spark Plug	Zündkerze Einschalten Boile	Candela di Accensione Caldaia
C.C.	Control Camara	Contrôle Chambre	Chamber Control	Steuerung Garraum	Controllo Camera
C.E.C	Control Combustión Cámara	Contrôle Combustion Chambre	Chamber Combustion Control	Steuerung Verbrennung Garraum	Controllo Combustione Camera
C.E.V	Control Combustión Caldera	Contrôle Combustion Chaudière	Boiler Combustion Control	Steuerung Verbrennung Boiler	Controllo Combustione Caldaia
C.G.	Control Gas	Contrôle Gaz	Control Gas	Steuern Sie Gas	Controlli il gas
C.V.	Control Caldera	Contrôle Chaudière	Boiler Control	Steuerung Boiler	Controllo Caldaia
CC1, CC2	Contactador Resistencia Cámara	Contacteur Élément Chauffant Chambre	Chamber Heating Element Contactor	Schütz Heizwiderstand Garraum	Contattore Resistenza Camera
CK1, CK2	Contactador General Calentamiento	Relais Élément Chauffant	Heating Element Relay	Relais Heizwiderstand	Relè Resistenza
CV1, CV2	Contactador Resistencias Caldera	Contacteur Élément Chauffant Chaudière	Boiler Heating Element Contactor	Schütz Heizwiderstand Boiler	Contattore Resistenza Caldaia
DEC	Detector Llama Cámara	Détecteur Flamme Chambre	Chamber Flame Detector	Flammendetektor Garraum	Rilevatore di Fiamma Camera
DEV	Detector Llama Caldera	Détecteur Flamme Chaudière	Boiler Flame Detector	Flammendetektor Boiler	Rilevatore di Fiamma Caldaia
DN	Detector Nivel Caldera	Détecteur Niveau Chaudière	Boiler Level Detector	Pegeldetektor Boiler	Rilevatore Livello Caldaia
F	Fusibles	Fusibles	Fuses	Sicherungen	Fusibili
FI	Filtro Interferencias	Filtre Interférences	Interference Filter	Störungsfilter	Filtro Interferenze
FM	Térmico Motor	Thermique Moteur	Thermal Engine	Thermoschalter Motor	Termico Motore
GV1, GV2	Electro válvula Gas Cámara	Électrovanne Gaz Chambre	Chamber Gas Solenoid Valve	Elektroventil Gas Garraum	Elettrovalvola Gas Camera
GV3, GV4	Electro válvula Gas Caldera	Électrovanne Gaz Chaudière	Boiler Gas Solenoid Valve	Elektroventil Gas Boiler	Elettrovalvola Gas Caldaia
Ip	Interruptor Seguridad Puerta	Interrupteur Sécurité Porte	Door Safety Switch	Sicherheitsschalter Tür	Itteruttore Sicurezza Porta
Lz	Luz Interior	Éclairage Intérieur	Inner Light	Innenbeleuchtung	Luce Interna
M, M2	Motor Turbina	Moteur Turbine	Turbine Engine	Motor Turbine	Motore Turbina
Ma	Interruptor Micro Abierto	Microrupteur Ouvert	Open Microswitch	Mikroschalter Geöffnet	Iterruttore Micro Aperto
Mb	Interruptor Micro Bajada	Microrupteur Descente	Drop Microswitch	Mikroschalter Senken	Iterruttore Micro Discesa
Mc	Interruptor Micro Cerrado	Microrupteur Fermé	Closed Microswitch	Mikroschalter Geschlossen	Iterruttore Micro Chiuso
Mch	Motor Chimenea	Moteur Cheminée	Stack Engine	Motor Abluftkamin	Motore Canna
MD	Motor Desague	Moteur évacuation	Drain Engine	Motor Abfluss	Motore scolo
Ms	Interruptor Micro Subida	Microrupteur Montée	Rise Microswitch	Mikroschalter Heben	Iterruttore Micro Salita
PF	Potenciómetro Selector Funciones	Potentiomètre Sélecteur Fonctions	Functions Selector Potentiometer	Potentiometer Funktionswahlschalter	Potenziometro Selettore Funzioni
RC	Resistencias Cámara	Éléments Chauffants Chambre	Chamber Heating Element	Heizwiderstände Garraum	Resistenze Camere
RG	Rele General	Relais Général	Main Relay	Hauptrelais	Relè principale
RV	Resistencias Caldera	Éléments Chauffants Chaudière	Boiler Heating Element	Heizwiderstände Boiler	Resistenze Caldaia
Tc	Sonda Cámara	Sonde Chambre	Chamber Probe	Sonde Garraum	Sonda Camera
TCN	Termostato Condensación	Thermostat Condensation	Condensation Thermostat	Thermostat Kondensierung	Termostato Condensazione
Tg	Sonda Caldera	Sonde Chaudière	Boiler Probe	Sonde Boiler	Sonda Caldaia
Tn	Sonda Núcleo	Sonde Noyau	Core Probe	Kerntemperaturmesssonde	Sonda Nucleo
TRF	Transformador	Transformateur	Transformer	Transformator	Trasformatore
TSC	Termostato Seguridad Cámara	Thermostat Sécurité Chambre	Chamber Safety Thermostat	Sicherheitsthermostat Garraum	Termostato Sicurezza Camera
TSV	Termostato Seguridad Caldera	Thermostat Sécurité Chaudière	Boiler Safety Thermostat	Sicherheitsthermostat Boiler	Termostato Sicurezza Caldaia
Tv	Sonda Vapor	Sonde Vapeur	Steam Probe	Sonde Dampf	Sonda Vapore
VAC	Bomba Vaciado	Pompe Vidange	Vacuum Pump	Ablasspumpe	Pompa scarico
MBA	Moto Bomba Aclarado	Pompe Rinçage	Rinsing Pump	Pumpe Ausspülen	Pompa Risciacquo
VC1, VC2	Ventilador Soplante Camara	Ventilateur Soufflant	Blowing Fan	Ventilator Gebläse	Ventilatore Soffiante
VCN	Electro válvula Condensación	Électrovanne Condensation	Condensation Solenoid Valve	Elektroventil Kondensierung	Elettrovalvola Condensazione
VDV	Electro válvula Llenado Caldera	Électrovanne Remplissage Chaudière	Chamber Filling Solenoid Valve	Elektroventil Füllung Boiler	Elettrovalvola di Rimpimento Caldaia
VE	Ventilador Cuadro Eléctrico	Ventilateur Tableau Électrique	Fan Switchboard	Ventilator Elektrotafel	Ventilatore Quadro Elettrico
VF1, VF2	Variador de Frecuencia	Variateur Vitesse	Speed Variator	Geschwindigkeitsregler	Variatore di Velocità
VHM	Electro válvula Humidificador	Électrovanne Humidificateur	Humidifier Solenoid Valve	Elektroventil Befeuchtungsvorrichtung	Elettrovalvola Umidificatore
Vv	Ventilador Soplante Caldera	Ventilateur soufflement chaudière	Boiler Blowing Fan	Durchbrennenventilator zum Dampfkessel	Ventilatore Soffiante caldaia
	COLORES	COULEURS	COLOUR	FARBEN	COLORE
a	Azul	Bleu	Blue	Blau	Blu
am	Amarillo	Jaune	Yellow	Gelb	Giallo
am/ve	Amarillo/verde	Jaune / vert	Yellow / green	Gelb/grün	Giallo/verde
b	Blanco	Blanc	White	Weiß	Bianco
g	Gris	Gris	Grey	Grau	Grigio
m	Marrón	Marron	Brown	Braun	Marrone
n	Negro	Noir	Black	Schwarz	Nero
na	Naranja	Orange	Orange	Orange	Arancio
r	Rojo	Rouge	Red	Rot	Rosso
rs	Rosa	Rose	Pink	Rosa	Roseo
ve	Verde	Vert	Green	Grün	Verde
vi	Violeta	Violet	Purple	Violett	Viola