

**Hornos Mixtos
Fours Mixtes
Combi Ovens
HeiBluftdämpfer
Forno Misti**

Modelos:

COE-102

VE-102

VPE-102

Septiembre 2009 September



Fagor Industrial

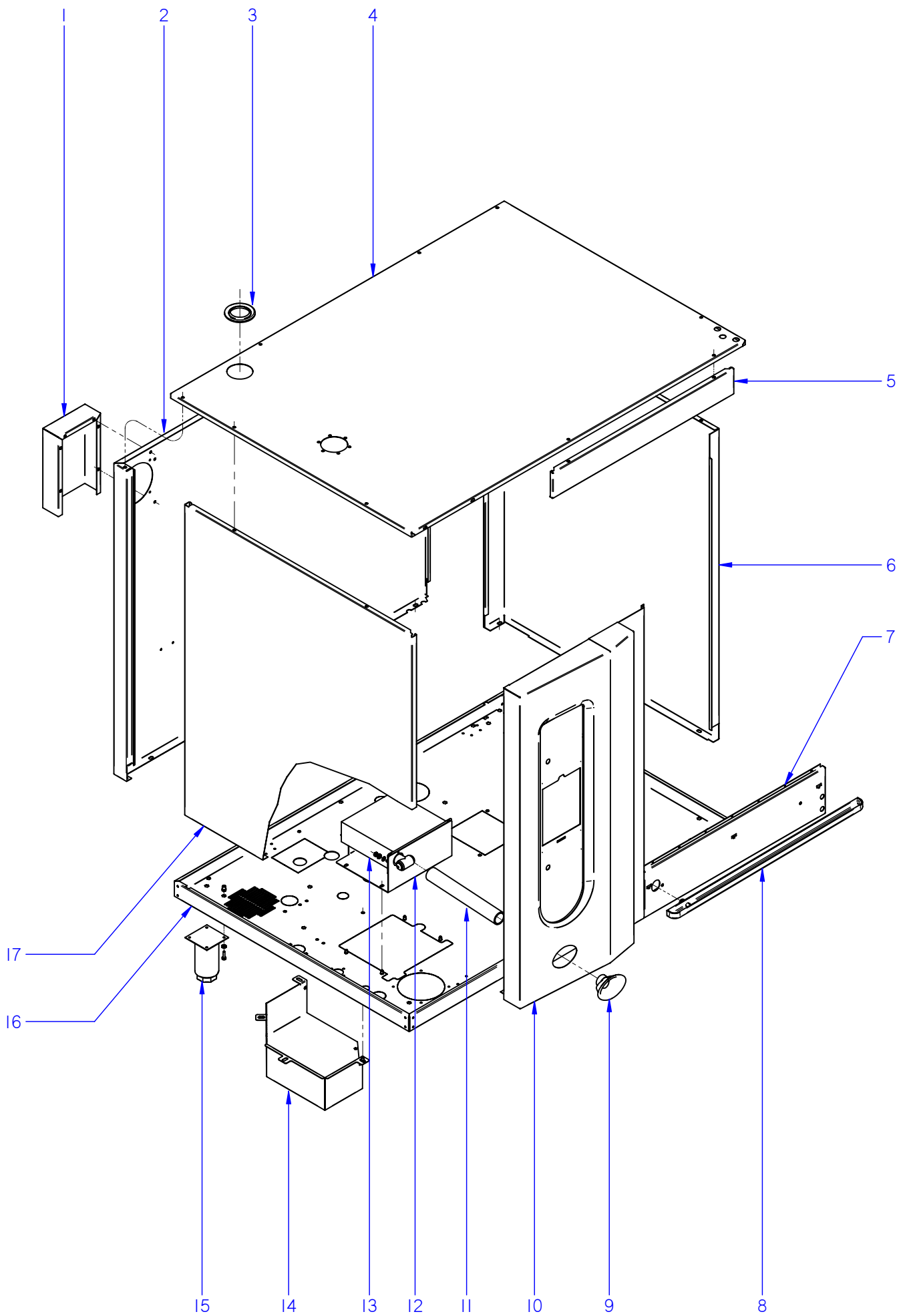

ITEM MARCADO EN COLOR = REPUESTO RECOMENDADO
 COLOURED ITEM = RECOMMENDED SPARE PART

N plano	Firma	Fecha	Aparato	MUEBLE	Lamina	Fagor Industrial S.Coop. FAGOR
C-2416	<i>(Signature)</i>	2009-09	HORNOS COE / VE / VPE-102		1	Oñate

MOD.		HORNOS / OVEN		ZONA	MUEBLE / UNIT			PLANO	C-2416	
ITEM	CODIGO	DENOMINACION	TEXTO	COE-102	VE-102	VPE-102				NOTAS
1	T812806500	CHAPA SEPARACION IPX5	SEPARATION PLATE IPX5	1	1	1				
	Q221342000	REMACHE EXAGONAL M5	HEXAGONAL RIVET M.5	6	6	6				
	Q232030000	ARANDELA A5	WASHER A.5	6	6	6				
	Q242030000	ARANDELA ABANICO A5 A.304	FAN SHAPED WASHER A.5	6	6	6				
	Q012031000	TORNILLO EXAGONAL M5x10 A304	HEXAGONAL SCREW M.5x10	6	6	6				
S/Nº	T812811000	JUNTA IPX5	SEAL IPX5	1	1	1				
2	T612802000	PANEL POST. EXTERIOR 10/21	REAR EXTERIOR PANEL10/21	1	1	1				
3	R662813000	PASAMUROS CHIMENEA 101003361	FEED THROUGH FLUE PIPE 1010	1	1	1				
4	T622801000	PANEL SUPER. EXTERIOR 10/21	SUP. EXTERIOR PANEL10/21	1	1	1				
	Q232040000	ARANDELA A6	WASHER A.6	7	7	7				
	Q242040000	ARANDELA ABANICO A6 A.304	FAN SHAPED WASHER A.6	7	7	7				
	Q012042000	TORNILLO EXAGONAL M6x15	HEXAGONAL BOLT M6x15	7	7	7				
	Q152004000	TORNIL. APLASTADO M5X13 A 304	FLAT SCREW M.5x13	7	7	7				
5	T642810000	PANEL FRONTAL SUPERIOR	UPPER FRONT PANEL	1	1	1				
6	T642812000	PANEL EXTERIOR DERECHO 10/21	RIGHT EXT. PANEL 10/21	1	1	1				
7	T642811000	PANEL FRONTAL INFERIOR	LOWER FRONT PANEL	1	1	1				
8	T302853000	RECOGEAGUAS PLASTICO	PLAST SPRING WATER COLLE.	1	1	1				
	Q222041000	REMACHE EXAGONAL M.4 INOX.	HEXAGONAL M.4 INOX.	2	2	2				
	Q242020000	ARANDELA ABANICO A4 A.304	FAN SHAPED WASHER A.4	2	2	2				
	Q032021000	TORNILLO ALOMADO M4x10	CURVED SCREW M.4x10	2	2	2				
9	T922801000	EMBELLECEDOR DUCHA	SHOWER TRIM	-	1	1				
10	T632803000	PANEL PORTAMANDOS 10-21 HEI	CONTROL PANEL 10-21 HEI	1	-	-				
10	T612804000	PANEL PORTAMANDOS 10-21 HEM	CONTROL PANEL 10-21 HEM	-	1	-				
10	T622803000	PANEL PORTAMANDOS 10-21 HEP	CONTROL PANEL 10-21 HEP	-	-	1				
	Q221342000	REMACHE EXAGONAL M5	HEXAGONAL RIVET M.5	3	3	3				
S/Nº	T612806000	JUNTA PORTAMAND. HORZ 10/21	CONTROL HOLDER SEAL HORZ	1	1	1				
11	3716000000	TUBO SILICONA ALTA Tª 35*27	HIGH SILICON PIPE Tª 35*27	-	1	1				
	Q881305000	ABRAZADERA 25*40	CLAMP 25*40	-	2	2				
12	T642815000	AMARRE DUCHA 10/21 COMPLETO	SHOWER FASTENING	-	1	1				

MOD.		HORNOS / OVEN		ZONA		MUEBLE / UNIT				PLANO		C-2416	
ITEM	CODIGO	DENOMINACION	TEXTO	COE-102	VE-102	VPE-102						NOTAS	
13	T452809000	DUCHA	SHOWER		1	1							
	Q232030000	ARANDELA A5	WASHER A.5		4	4							
	Q242030000	ARANDELA ABANICO A5 A.304	FAN SHAPED WASHER A.5		4	4							
	Q012031000	TORNILLO EXAGONAL M5x10 A304	HEXAGONAL SCREW M.5x10		4	4							
14	T330747000	CAJA CUBRE SISTEMA LAVADO	CLEANING SYSTEM BOX			1							
	Q221342000	REMACHE EXAGONAL M.5	HEXAGONAL RIVET M.5			2							
	Q232030000	ARANDELA A5	WASHER A.5			3							
	Q242030000	ARANDELA ABANICO A5 A.304	FAN SHAPED WASHER A.5			3							
	Q012032000	TORNILLO EXAGONAL M5X15	HEXAGONAL BOLT M5X15			3							
S/Nº	T330748000	TAPA CAJA CUBRE SIST LAVADO	COVER WASHING SYSTEM BOX			1							
	Q152004000	TORNILLO APLAST. M5X13 A 304	FLAT SCREW M.5x13			2							
15	X260151000	PATA REGULABLE	REGULABLE LEG	4	4	4							
	Q232040000	ARANDELA A6	WASHER A.6	16	16	16							
	Q242040000	ARANDELA ABANICO A6 A.304	FAN SHAPED WASHER A.6	16	16	16							
	Q012043000	TORNILLO EXAGONAL M6x20	HEXAGONAL BOLT M6x20	16	16	16							
16	T612801000	BASE EXTERIOR 10/21	EXTERIOR BASE 10/21	1	1	1							
	Q221343000	REMACHE EXAGONAL M.6	HEXAGONAL RIVET M.6	32	32	32							
	Q221342000	REMACHE EXAGONAL M.5	HEXAGONAL RIVET M.5	7	7	7							
17	T642816000	PANEL EXTER. IZQUIERDO 10/21	REAR LEFT PANEL 10/21	1	1	1							
	Q221342000	REMACHE EXAGONAL M.5	HEXAGONAL RIVET M.5	2	2	2							
	Q232040000	ARANDELA A6	WASHER A.6	2	2	2							
	Q242040000	ARANDELA ABANICO A6 A.304	FAN SHAPED WASHER A.6	2	2	2							
	Q012042000	TORNILLO EXAGONAL M6x15	HEXAGONAL BOLT M6x15	2	2	2							
	Q152004000	TORNIL. APLASTADO M5X13 A 304	FLAT SCREW M.5x13	2	2	2							

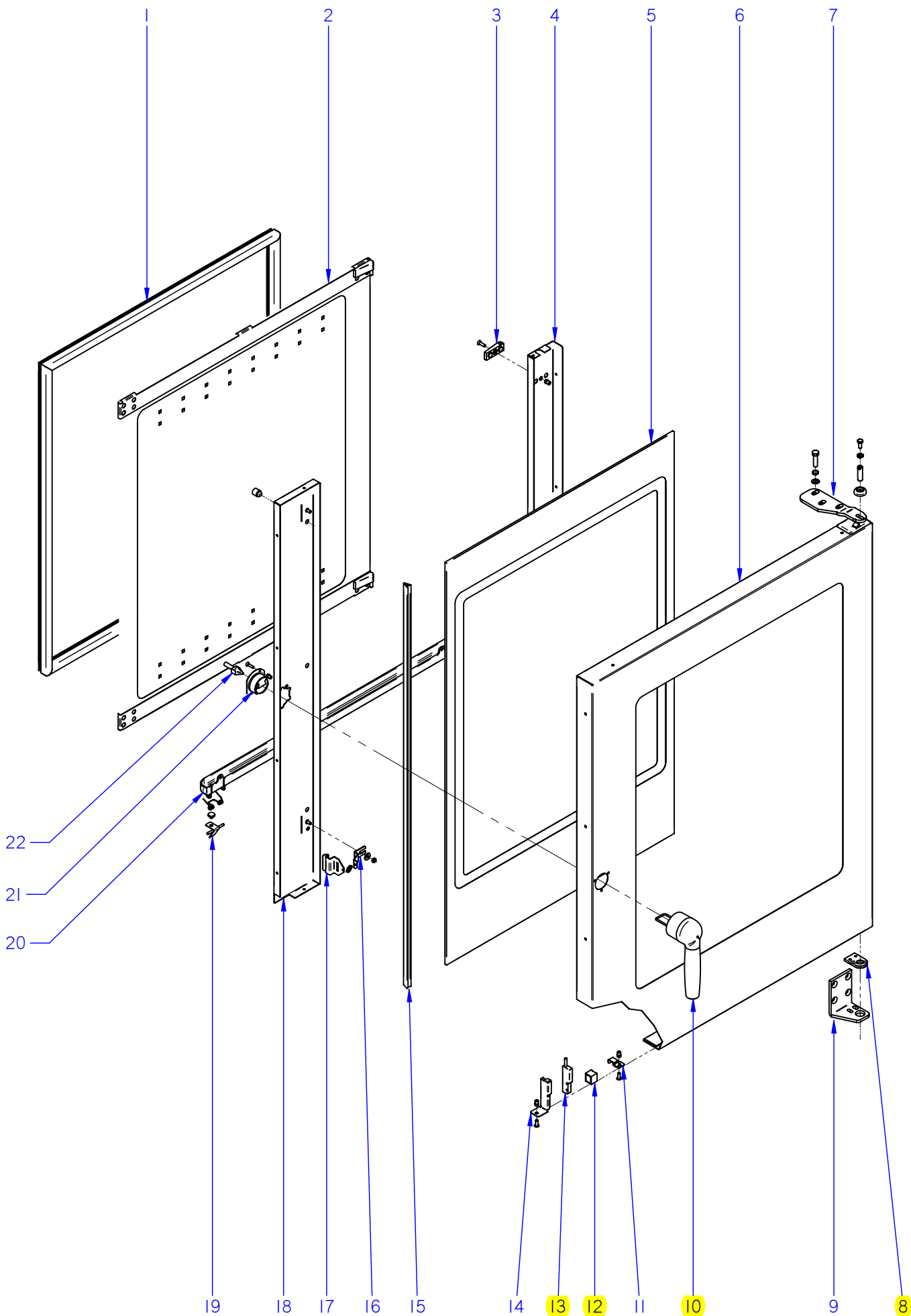

ITEM MARCADO EN COLOR = REPUESTO RECOMENDADO
 COLOURED ITEM = RECOMMENDED SPARE PART

N plano	Firma	Fecha	Aparato	PUERTA	Lamina	Fagor Industrial S.Coop. FAGOR
C-2417	<i>[Signature]</i>	2009-09	HORNOS COE / VE / VPE-102		2	Oñate

MOD.		HORNOS / OVEN		ZONA	PUERTA / DOOR			PLANO	C-2417
ITEM	CODIGO	DENOMINACION	TEXTO	COE-102	VE-102	VPE-102			NOTAS
	1100003143	KIT PUERTA 10/21 COMPL.	DOOR 10/21 KIT	1	1	1			
1	T300500000	JUNTA DE PUERTA 10/21	DOOR JOINT 10/21	1	1	1			
2	1100003136	KIT CRISTAL INTER. 10/21	10/21 INNER GLASS KIT	1	1	1			
3	R670615000	BASE DE BISAGRA	HINGE BASE	2	2	2			
	Q042032000	TORNILLO AVELLANADO M5X15	COUNTERSUNK SCREW M.5x15	2	2	2			
4	T640504000	CONTRAPUERTA BISAGRA 10/21	INNER DOOR HINGE 10/21	1	1	1			
	Q222011000	REMACHE EXAGONAL M.5	HEXAGONAL RIVET M.5	3	3	3			
5	T300546000	CRISTAL EXTERIOR 10/21	EXTERNAL GLASS 10/21	1	1	1			
6	T640502000	PANEL PUERTA 10/21	DOOR PANEL 10/21	1	1	1			
7	T300520500	BISAGRA SUPERIOR 10/21	UPPER HINGE 10/21	1	1	1			
	Q302025000	ARANDELA 8,4X20X1.5	WASHER 8,4X20X1.5	3	3	3			
	Q261050000	ARANDELA MUELLE A8	SPRING WASHER A8	3	3	3			
	Q012055000	TORNILLO EXAGONAL M8X30	HEXAGONAL BOLT M8X30	3	3	3			
S/Nº	R660534000	EJE SUPERIOR	UPPER SHAFT	1	1	1			
	R662807000	ARANDELA AMARRE	DOOR ANCHORING WASHER	1	1	1			
	Z850519000	RESORTE 06329	SPRING 06329	1	1	1			
8	R660549000	GUIA EJE INFERIOR FUNDIDO	LOWER SHAFT GUIDE	1	1	1			
	Q062040000	TORNILLO AVELLANADO M6X16	COUNTERSUNK SCREW M.6x16	4	4	4			
9	T300521500	BISAGRA INFERIOR PLEGADA	LOWER FOLDER HINGE	1	1	1			
10	T900506000	MANILLA COMPLETA	HANDLE	1	1	1			
	Q042022000	TORNILLO AVELLANADO M4X15	COUNTERSUNK SCREW M.4x15	3	3	3			
11	T130513000	SOPORTE IMAN	MAGNET HOLDER	1	1	1			
	Q222011000	REMACHE EXAGONAL M.5	HEXAGONAL RIVET M.5	1	1	1			
	Q242030000	ARANDELA ABANICO A5 A.304	FAN SHAPED WASHER A.5	1	1	1			
	Q152004000	TORNIL. APLASTADO M5X13 A 304	FLAT SCREW M.5x13	1	1	1			
12	Z200506000	IMAN	MAGNET	1	1	1			
S/Nº	Z200507000	PROTECTOR IMAN	MAGNET PROTECTOR	1	1	1			
13	Z100522000	INTERRUPTOR MAGNETICO AC	MAGNETIC SWITCH AC	1	1	1			
14	T302819000	SOPORTE MICRO PUERTA	DOOR MICRO SWITCH	1	1	1			
	Q152004000	TORNIL. APLASTADO M5X13 A 304	FLAT SCREW M.5x13	1	1	1			
15	3715200000	JUNTA CRISTAL	WINDOW SEAL	2	2	2			

N plano	Firma	Fecha	Aparato	MUEBLE INTERIOR	Lamina
C-2418		2009-09	HORNOS COE / VE / VPE-102		3
Fagor Industrial S. Coop. FAGOR					

ITEM MARCADO EN COLOR = REPUESTO RECOMENDADO
 COLOURED ITEM = RECOMMENDED SPARE PART

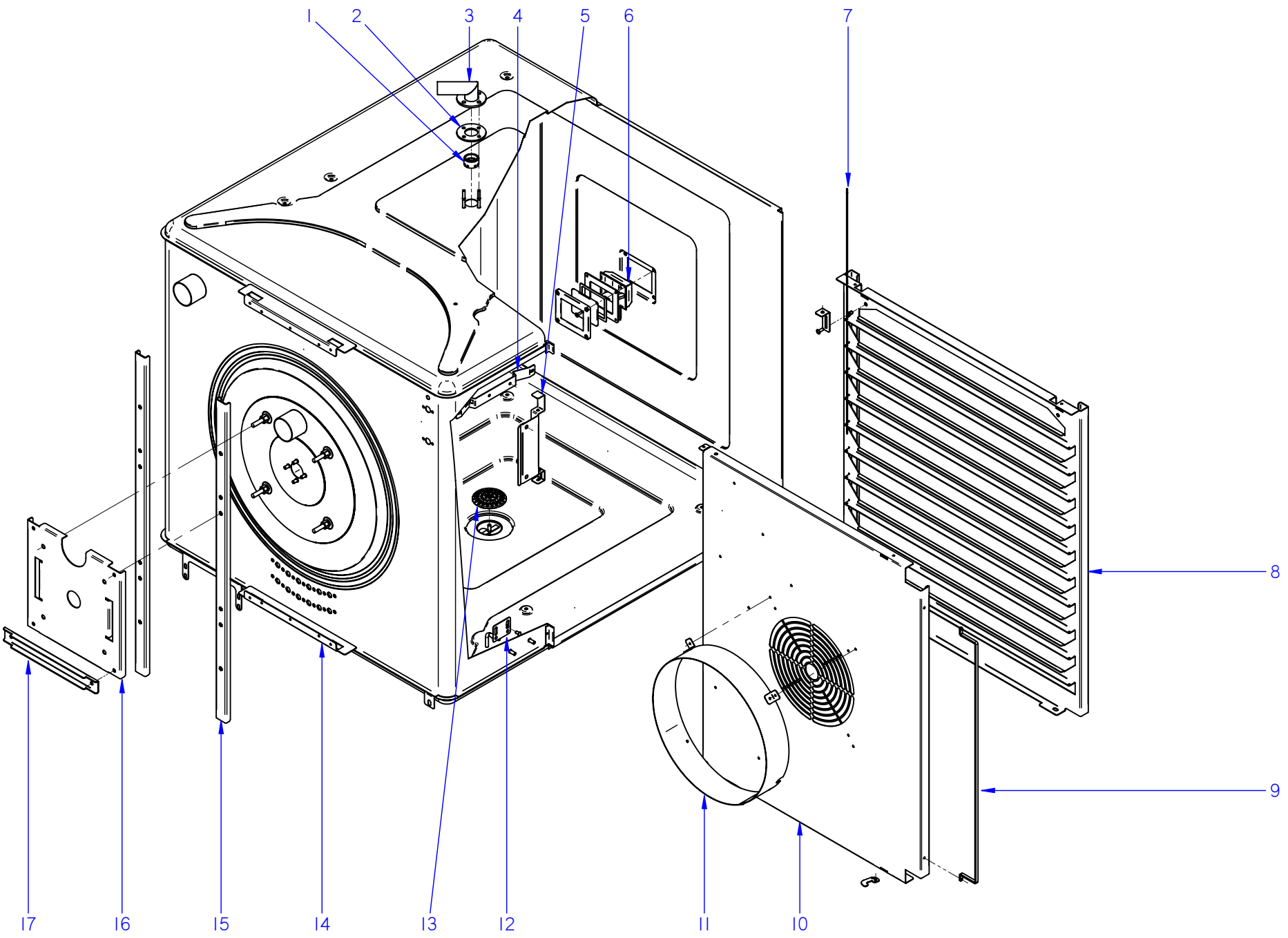

MOD.		HORNOS / OVEN		ZONA		MUEBLE INTERIOR / INTERIOR OVEN		PLANO		C-2418	
ITEM	CODIGO	DENOMINACION	TEXTO	COE-102	VE-102	VPE-102					NOTAS
1	T360712000	PUNTA DIFUSORA LAVADO	WASHING DISPENSER POINT	-	-	1					
2	T330744000	CHAPA AMARRE TUBO LAVADO	WASHING PIPE FASTENING PLAT	-	-	1					
3	T820702000	TUBO DIFUSOR LAVADO COMP.	COMPL. WASHING DISPENSER P	-	-	1					
	Q232030000	ARANDELA A5	WASHER A.5	-	-	4					
	Q242030000	ARANDELA ABANICO A5 A.304	FAN SHAPED WASHER A.5	-	-	4					
	Q162030000	TUERCA EXAGONAL M5	HEXAGONAL NUT M.5	-	-	4					
4	R662683000	SOPORTE BULBO	BULB SUPPORT	1	1	1					
	Q412002000	REMACHE AVINOX Ø4x10MM	TUBULAR RIVET 4x7,5	4	4	4					
5	T302644000	SOPORTE SONDA	PROBE SUPPORT	-	1	1					
	Q232030000	ARANDELA A5	WASHER A.5	-	2	2					
	Q242030000	ARANDELA ABANICO A5 A.304	FAN SHAPED WASHER A.5	-	2	2					
	Q162030000	TUERCA EXAGONAL M5	HEXAGONAL NUT M.5	-	2	2					
6	T303023000	PORTALAMPARAS	LAMP HOLDER	1	1	1					
S/Nº	T303026000	JUNTA EXTERIOR LAMPARA	LAMP OUTER JOINT	1	1	1					
S/Nº	T303025000	CRISTAL LAMPARA	LAMP GLASS	1	1	1					
S/Nº	T303027000	JUNTA INTERIOR LAMPARA	LAMP INNER JOINT	1	1	1					
S/Nº	T303047000	MARCO LAMPARA	LAMP ANCHORING PLATEN	1	1	1					
S/Nº	R663013000	LAMPARA 10W-12V	LIGHT 10W 12V	1	1	1					
	Q222041000	REMACHE EXAGONAL M.4 INOX	HEXAGONAL RIVET M.4	4	4	4					
	Q032021000	TORNILLO ALOMADO M4X10	CURVED SCREW M.4x10	4	4	4					
7	T302692000	TOPE DE BANDEJAS 10/21	TRAY HOLDER BUFFER 10/21	2	2	2					
8	T322611000	PORTABANDEJAS 10/21	TRAY HOLDER 10/21	2	2	2					
S/Nº	T302688000	ENGANCHE PORTABANDEJAS	TRAY HOLDER FASTENER	2	2	2					
	Q222041000	REMACHE EXAGONAL M.4	HEXAGONAL RIVET M.4	2	2	2					
	Q232020000	ARANDELA A4	WASHER A.4	2	2	2					
	Q242020000	ARANDELA ABANICO A4	FAN SHAPED WASHER A.4	2	2	2					
	Q032021000	TORNILLO ALOMADO M4x10	CURVED SCREW M.4x10	2	2	2					
S/Nº	T302690000	CIERRE PORTABANDEJAS 10/21	TRAY HOLDER CLOSURE 10/21	2	2	2					
	Q412002000	REMACHE AVINOX Ø4x10	RIVET AVINOX Ø4x10	2	2	2					
9	T302618000	PROTECCION INTERIOR	INTERIOR PROTECTION	1	1	1					

N plano	Firma	Fecha	Aparato	TURERINA	Lamina	Fagor Industrial S. Coop.
C-2419		2009-09	HORNOS COE / VE / VPE-102		4	

ITEM MARCADO EN COLOR = REPUESTO RECOMENDADO
 COLOURED ITEM = RECOMMENDED SPARE PART

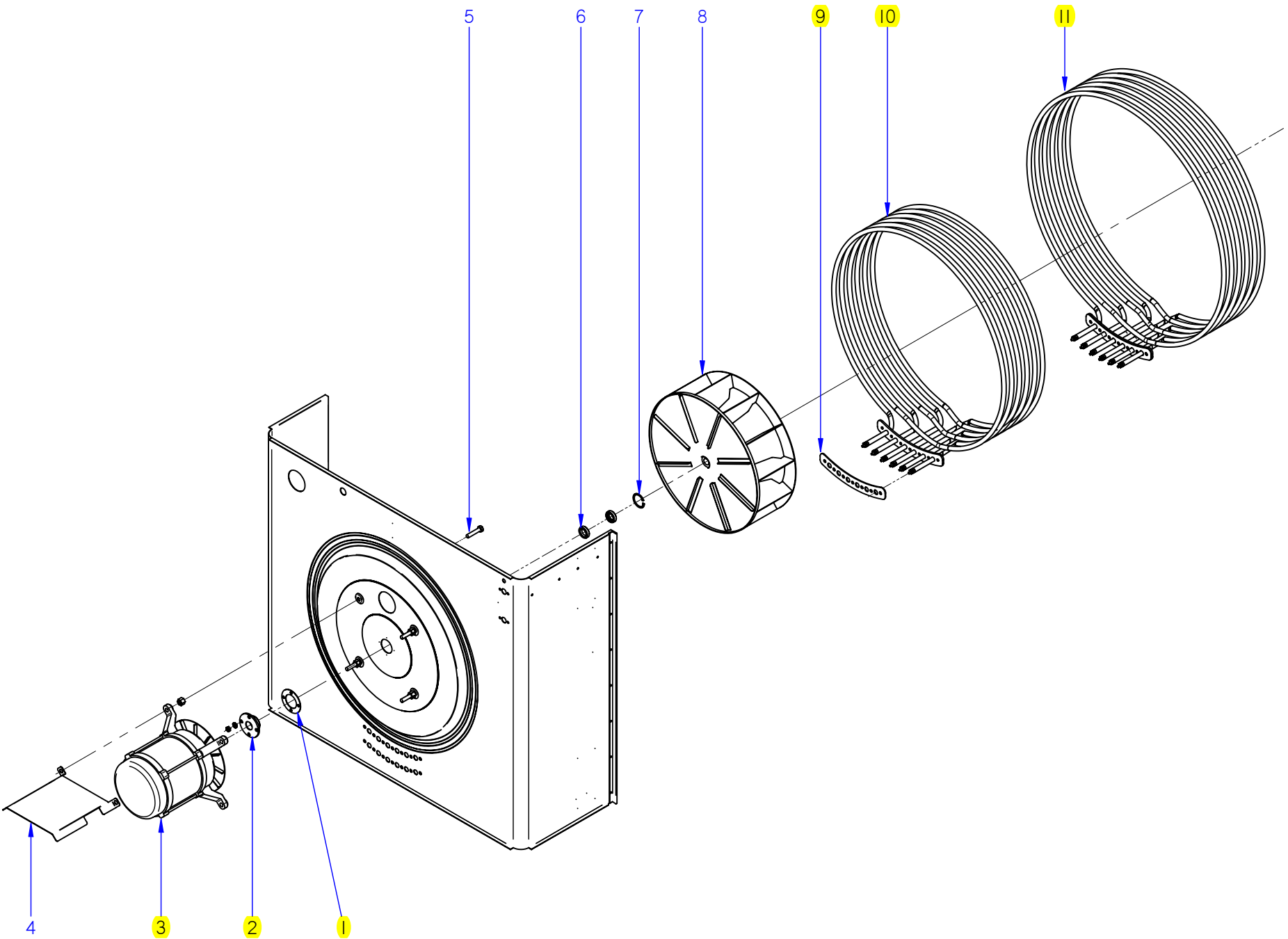

N plano	Firma	Fecha	Aparato	CHIMENEA	Lamina	Fagor Industrial S. Coop.
C-2420		2009-09	HORNOS COE / VE / VPE-102		5	Omate

ITEM MARCADO EN COLOR = REPUESTO RECOMENDADO
COLOURED ITEM = RECOMMENDED SPARE PART

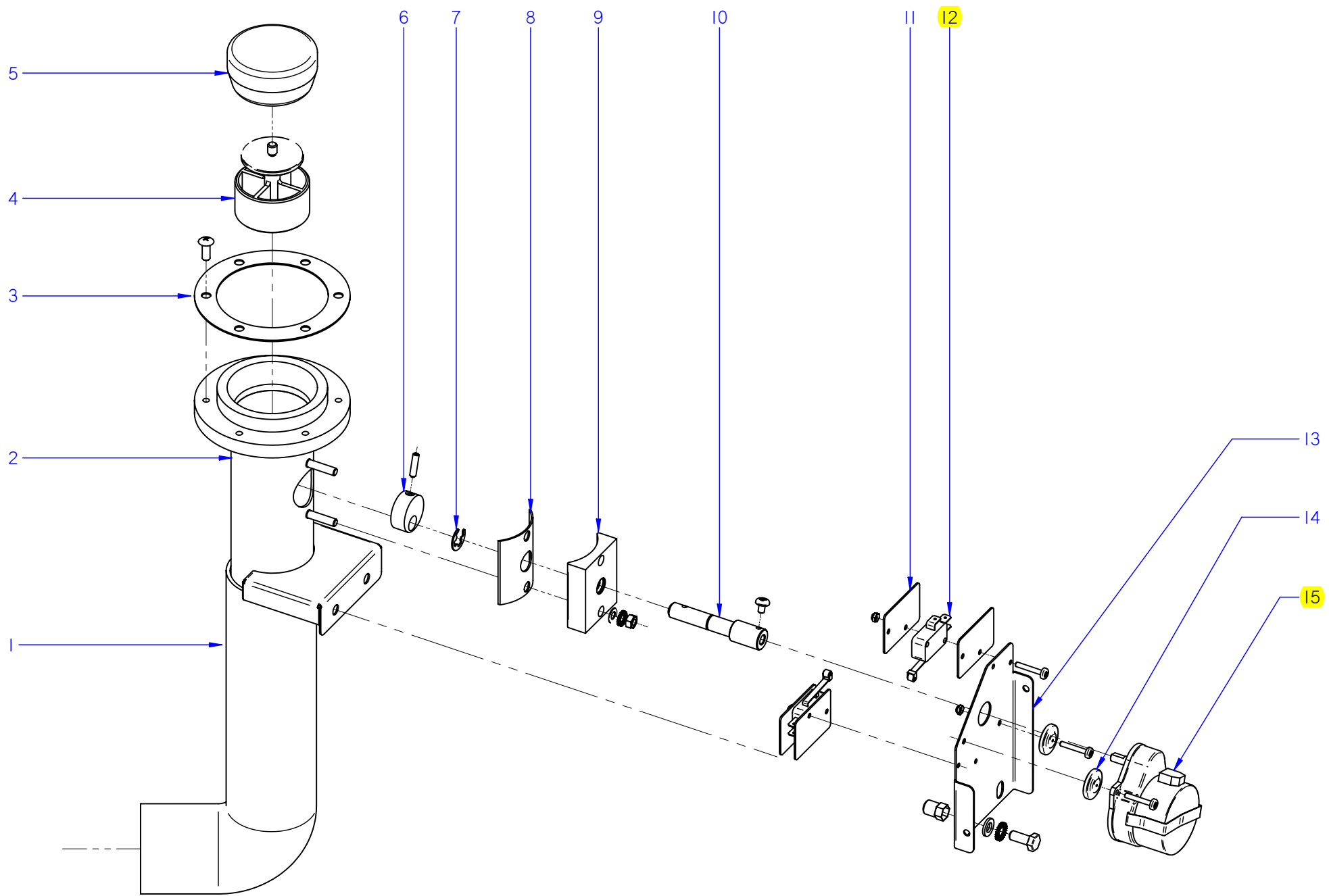

MOD.		HORNOS / OVEN		ZONA		CHIMENEA / FLUEPIPE			PLANO		C-2420	
ITEM	CODIGO	DENOMINACION	TEXTO	COE-102	VE-102	VPE-102						NOTAS
1	T722608000	TUBO FLEXIBLE Ø53X360	FLEXIBLE TUBE Ø53X360	1	1	1						
	Q881307000	ABRAZADERA 40*60	CLAMP 40*60	2	2	2						
2	T815006000	CONJUNTO CHIMENEA	COMPLETE CHIMNEY	1	1	1						
	Q221343000	REMACHE EXAGONAL M.6	HEXAGONAL RIVET M.6	2	2	2						
3	T325057000	JUNTA BASE CHIMENEA	FLUEPIPE BASE SEAL	1	1	1						
	Q152004000	TORNIL. APLASTADO M5X13 A 304	FLAT SCREW M.5x13	6	6	6						
4	T815014000	GUIA RETENCION VAPORES	STEAM RETAINER GUIDE	1	1	1						
5	T325055000	RETENCION DE VAPORES	CLOSE CHIMNEY	1	1	1						
6	T325032000	LEVA EJE CHIMENEA	FLUEPIPE SHAFT CAM	1	1	1						
	Q132045000	VARILLA ROSCADA M4X16	THREADED ROD M4X16	1	1	1						
7	Q271006000	ARANDELA DE SEGURIDAD Ø8	SAFETY WASHER Ø8	1	1	1						
8	T325030000	JUNTA EJE CHIMENEA	FLUEPIPE SHAFT SEAL	1	1	1						
9	T325029000	GUIA EJE CHIMENEA	FLUEPIPE SHAFT GUIDE	1	1	1						
	Q232030000	ARANDELA A5	FLAT WASHER A.5	2	2	2						
	Q242030000	ARANDELA ABANICO A5 A.304	FAN SHAPED WASHER A.5	2	2	2						
	Q162030000	TUERCA EXAGONAL M5	HEXAGONAL NUT M.5	2	2	2						
10	T815010000	EJE CHIMENEA ELECTRICA	ELECTRIC FLUEPIPE SHAFT	1	1	1						
	Q151320000	TORNILLO ALOMADO M4X6 ZINC.	CURVED SCREW M4X6 ZINC.	1	1	1						
11	R010535000	PLACA SEPARADORA	SPACER PLATE	4	4	4						
	Q032013000	TORNILLO ALOMADO M3X20	CURVED SCREW M3X20	4	4	4						
	Q221350000	TUERCA AUTOBLOCANTE M3	SELF-LOCKING NUT M3	4	4	4						
12	R010534000	INTERRUPTOR PUERTA	DOOR SWITCH	2	2	2						
13	T815009000	ESCUA. AMARRE MOTOR CHIMEN.	FLUEPIPE MOTOR FASTENING B	1	1	1						
	Q232040000	ARANDELA A6	FLAT WASHER A.6	2	2	2						
	Q242040000	ARANDELA ABANICO A6 A.304	FAN SHAPED WASHER A.6	2	2	2						
	Q012042000	TORNILLO EXAGONAL M6X15 A304	HEXAGONAL SCREW M6X15	2	2	2						
14	R675033000	JUNTA PALANCA ACCIONAMIENTO	DRIVE LEVER SEAL	3	3	3						
15	T323010000	MOTOR CHIMENEA	FLUEPIPE MOTOR	1	1	1						

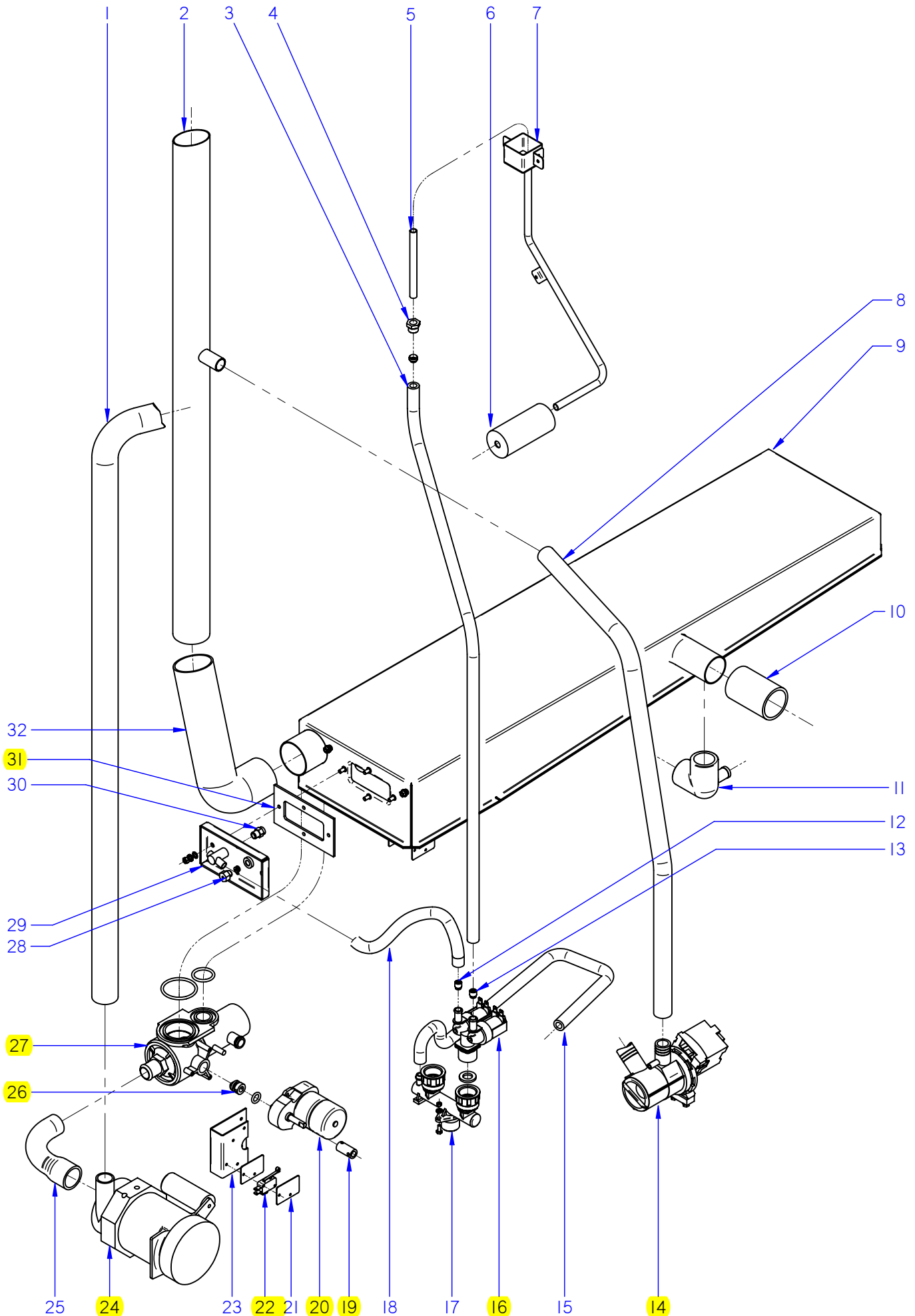

ITEM MARCADO EN COLOR = REPUESTO RECOMENDADO
 COLOURED ITEM = RECOMMENDED SPARE PART

N plano	Firma	Fecha	Aparato	CIRCUITO DE AGUA	Lamina	Fagor Industrial S.Coop. FAGOR
C-2421	<i>(Signature)</i>	2009-09	HORNOS COE / VE / VPE-102		6	Oñate

MOD.		HORNOS / OVEN		ZONA		CONDUCCIONES DE AGUA / WATER PIPES				PLANO		C-2421	
ITEM	CODIGO	DENOMINACION	TEXTO	COE-102	VE-102	VPE-102							NOTAS
1	3716000000	TUBO SILICONA T° Ø 35*27	HIGH SILICON PIPE T° Ø 35*27	-	-	1							
	Q881305000	ABRAZADERA 25-40	CLAMP 25-40	-	-	2							
2	T355007000	CHIMENEA COMPLETA HEI 10/21	COMPLET FLUEPIPE HEI 10/21	1	-	-							
2	T325050000	CHIMENEA COMPLETA 10/21	COMPLET FLUEPIPE 10/21	-	1	1							
3	3676900000	T. GOMA NEGRA Ø17*10 INYECT.	BLACK RUBBER PIPE Ø17*10	1	1	1							
	Q881302000	ABRAZADERA 12*20	CLAMP 12-20	2	2	2							
4	R695003000	MANGUITO CIERRE	CLOSING SLEEVE	1	1	1							
	R695004000	BICONO	BICONE	1	1	1							
5	T355001000	TUBO INYECTOR	INJECTOR PIPE	1	-	-							
5	R695033000	TUBO INYECTOR 6/11	INJECTOR PIPE	-	1	1							
6	R665025000	DISTRIBUIDOR INYECTOR	INJECTOR DISTRIBUTOR	1	-	-							
7	T355005000	INYECTOR COMPLETO HEI 1	COMPLETE INJECTOR HEI	1	-	-							
8	3715900000	TUBO SILICONA T° Ø 26*18	HIGH SILICON PIPE T° Ø 26*18	-	1	1							
	Q901311000	ABRAZADERA ELASTICA 26,7*28,1	ELAST. CLAMP 26,7*28,1	-	2	2							
9	T915005000	CAJA DESAGÜE LAVADO	COM. DRAINAGE BOX	1	1	-							
9	T625001000	CONJUNTO CAJA LAVADO	COMPLETE WASH BOX	-	-	1							
	Q232040000	ARANDELA A6	WASHER A.6	2	2	2							
10	3715800000	TUBO SILICONA T° Ø 43*51	HIGH SILICON PIPE T° Ø 43*51	1	1	1							
	Q881307000	ABRAZADERA 40*60	CLAMP 40*60	2	2	2							
11	R665080000	CODO DESAGUE	DRAINAGE L-BEND	1	1	-							
S/Nº	T815001000	CONDUCCIÓN DESAGÜE 6-10/11 E	DRAINAGE DUCT 6-10/11 E	1	1	-							
12	P443042000	REGULADOR 3 L. VERDE 254,023	REGULATOR 3 L. GREEN	1	1	1							
13	R715011000	REGULADOR 0.5L. NARANJA	REGULATOR 0.5L. ORANGE	1	1	1							
14	Z220901000	BOMBA DESAGÜE 30W	DRAINAGE PUMP 30W	-	1	1							
15	3676900000	TUBO GOMA NEGRA Ø17*10	BLACK RUBBER PIPE Ø17*10	1	1	1							
	Q881302000	ABRAZADERA 12*20	CLAMP 12-20	2	2	2							
16	P255001000	ELECTROVALVULA DOBLE	DOUBLE SOLENOID VALVE	1	1	1							

MOD.		HORNOS / OVEN		ZONA		CONDUCCIONES DE AGUA / WATER PIPES			PLANO		C-2421	
ITEM	CODIGO	DENOMINACION	TEXTO	COE-102	VE-102	VPE-102						NOTAS
17	T325063000	ENTRADA DE AGUA COMPLETA	COMPLETE WATER INLET	-	1	1						
	Q307031000	JUNTA TUBO 14X24X3	JOINT 14X24X3	-	2	2						
	Q012021000	TORNILLO EXAGONAL M4x10 A304	HEXAGONAL BOLT M4x10 A304	-	2	2						
	Q242010000	ARANDELA ABANICO A3 A.304	FAN SHAPED WASHER A.3	-	2	2						
	Q162020000	TUERCA EXAGONAL M4	HEXAGONAL NUT M.4°	-	2	2						
18	3676900000	TUBO GOMA NEGRA Ø17*10	BLACK RUBBER PIPE Ø17*10	1	1	1						
	Q881302000	ABRAZADERA 12*20	CLAMP 12-20	2	2	2						
19	T330733000	CASQUILLO MOTOR MICRO	MICRO MOTOR BUSHING	-	-	1						
	Q151320000	TORNILLO ALOMADO M4X6 H.ZIN.	CURVED SCREW M4X6 H.ZIN.	-	-	2						
	Q371026000	MANGUITO SUJEC. 4X14 DIN1481	HOSE FASTENING 4X14 DIN1481	-	-	1						
	Q052032000	TORNILLO ALLEN M.5x15(+)	ALLEN HEAD SCREW M.5x15(+)	-	-	2						
20	T330711000	MOTOR VALVULA	VALVE MOTOR	-	-	1						
	Q042022000	TORNILLO AVELLANADO M4X15	COUNTERSUNK SCREW M.4x15	-	-	2						
21	R010535000	PLACA SEPARADORA	SPACER PLATE	-	-	4						
	Q032013000	TORNILLO ALOMADO M3X20	CURVED SCREW M3X20	-	-	7						
	Q221350000	TUERCA AUTOBLOCANTE M3	SELF-LOCKING NUT M3	-	-	7						
22	R010534000	INTERRUPTOR PUERTA	DOOR SWITCH	-	-	2						
23	T330713000	CHAPA SUJECCION MICROS	FASTENING PLATE MICROS	-	-	1						
24	T360715000	MOTOBOMBA 5213E2450 FIR 50Hz	MOTOR-PUMP 5213E2450 FIR	-	-	1						
	Q232040000	ARANDELA A6	WASHER A.6	-	-	2						
	Q242040000	ARANDELA ABANICO A6 A.304	FAN SHAPED WASHER A.6	-	-	2						
	Q012043000	TORNILLO EXAGONAL M6X20	HEXAGONAL SCREW M6X20	-	-	2						
25	T330731000	GOMA VALVULA BOMBA	PUMP VALVE RUBBER	-	-	1						
	Q881304000	ABRAZADERA 20-32	CLAMP 20-32	-	-	1						
	Q881305000	ABRAZADERA 25-40	CLAMP 25-40	-	-	1						
26	T330707000	PUNTA ACOPLA MOTOR A VALVUL	CONN. POINT MOTOR TO VALVE	-	-	1						
	Q307084000	JUNTA TORICA Ø18X3.5	O-RING Ø18X3.5	-	-	1						
27	T330723000	CUERPO VALVULA COMPLETO	COMPLETE VALVE BODY	-	-	1						
	Q307080000	JUNTA TORICA Ø52X3,5	O-RING Ø52X3.5	-	-	1						
	Q307079000	JUNTA TORICA Ø33x3,5	O-RING Ø33x3.5	-	-	1						

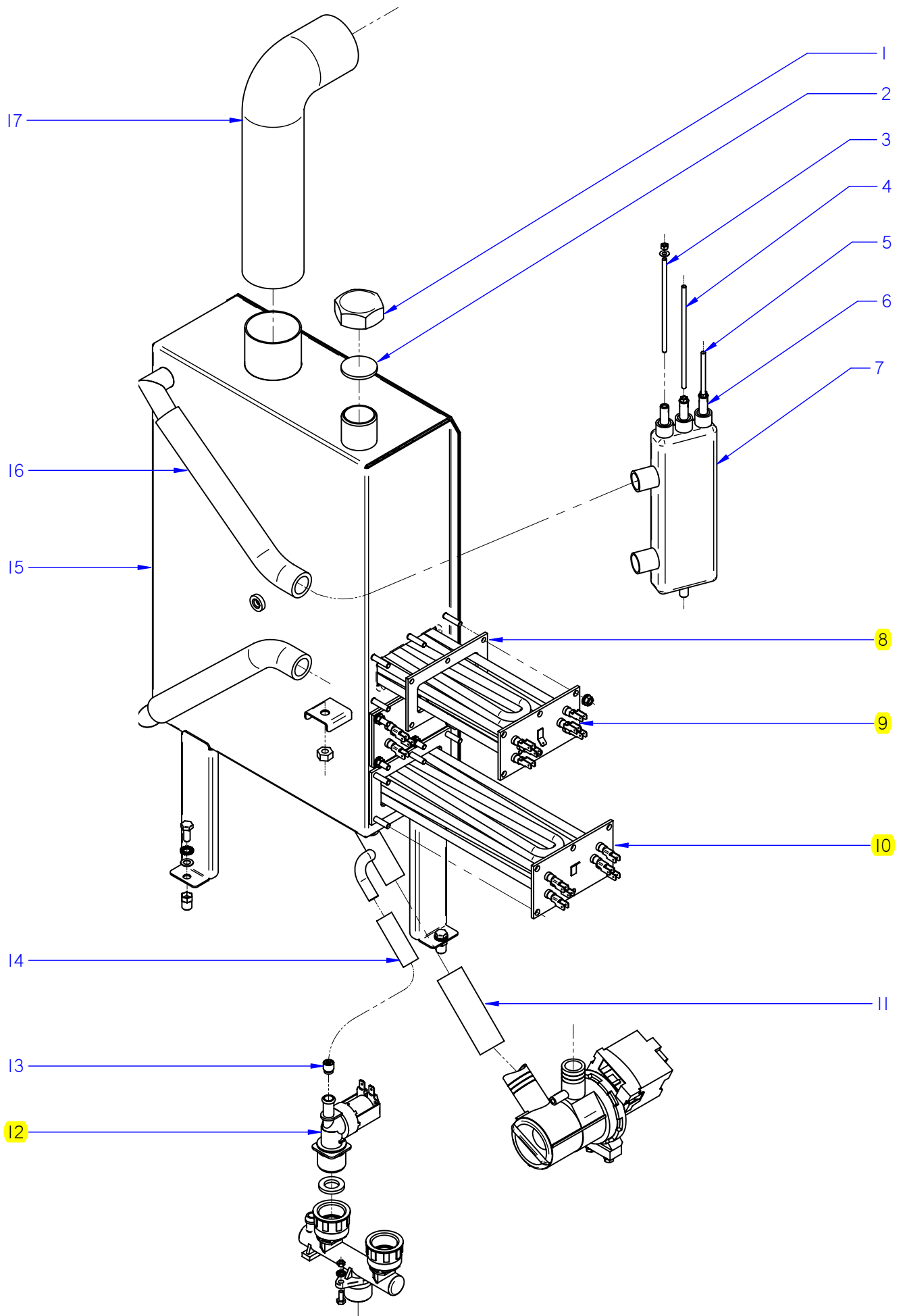

ITEM MARCADO EN COLOR = REPUESTO RECOMENDADO
 COLOURED ITEM = RECOMMENDED SPARE PART

N plano	Firma	Fecha	Aparato	CIRCUITO DE VAPOR	Lamina	Fagor Industrial S.Coop. FAGOR
C-2422	<i>(Signature)</i>	2009-09	HORNOS VE-102 / VPE-102		7	Oñate

MOD.		HORNOS / OVEN		ZONA		CIRCUITO DE VAPOR / STEAM CIRCUIT				PLANO		C-2422	
ITEM	CODIGO	DENOMINACION	TEXTO	VE-102	VPE-102							NOTAS	
1	R015010000	TUERCA TAPON 1"	PLUG NUT 1"	1	1								
2	R015011000	ARANDELA Ø32	WASHER Ø32	1	1								
3	R345060000	ELECTRODO ALTO	HIGH LEVEL ELECTRODE	1	1								
4	R345063000	ELECTRODO BAJO	LOW LEVEL ELECTRODE	1	1								
5	R345064000	ELECTRODO DE MASA	EARTH ELECTRODE	1	1								
	Q232020000	ARANDELA A4	FLAT WASHER A.4	3	3								
	Q162020000	TUERCA EXAGONAL M4	HEXAGONAL NUT M.4°	3	3								
6	R345069000	GUIA AISLANTE	INSULATION GUIDE	3	3								
7	T325077000	BOTE DE NIVELES	LEVELS VESSEL	1	1								
	Q228051000	TUERCA EXAGONAL M8 PLASTIC	HEXAGONAL NUT M8 PLASTIC	1	1								
8	T323007000	JUNTA CIERRE RESISTENCIAS	RESISTOR SEAL	3	3								
	Q232030000	ARANDELA A5	WASHER A.5	18	18								
	Q242030000	ARANDELA ABANICO A5 A.304	FAN SHAPED WASHER A.5	18	18								
	Q163030000	TUERCA EXAGONAL M5 LATON	HEXAGONAL NUT M5	18	18								
9	T323006000	RESISTENCIA 3x3000W 230V	RESISTOR 3x3000W 230V	1	1								
10	T323038000	RESISTENCIA 3x3000W 230V	RESISTOR 3x3000W 230V	2	2								
11	3715900000	TUBO SILICONA T° Ø 26*18	HIGH SILICON PIPE T° Ø 26*18	1	1								
	Q901311000	ABRAZADERA ELASTICA 26,7*28,1	ELAST. CLAMP 26,7*28,1	2	2								
12	Z701135000	ELECTROVALVUL. SIMPLE 255.208	SIMPLE SOLENOID VALVE	1	1								
13	Z601156000	REGULADOR 8L RO 254.034	REGULATOR 8L RED 254.034	1	1								
14	3676900000	T. GOMA NEGRA Ø17*10	BLACK RUBBER PIPE Ø17*10	1	1								
	Q881302000	ABRAZADERA 12*20	CLAMP 12-20	2	2								
15	1100003144	KIT GENERADOR DE VAPOR	STEAM GENERATOR KIT	1	1								
16	3715900000	TUBO SILICONA T° Ø 26*18	HIGH SILICON PIPE T° Ø 26*18	1	1								
	Q901311000	ABRAZADERA ELASTICA 26,7*28,1	ELAST. CLAMP 26,7*28,1	2	2								
17	T722608000	TUBO FLEXIBLE Ø53X360	FLEXIBLE TUBE Ø53X360	1	1								
	Q881307000	ABRAZADERA 40*60	CLAMP 40*60	2	2								

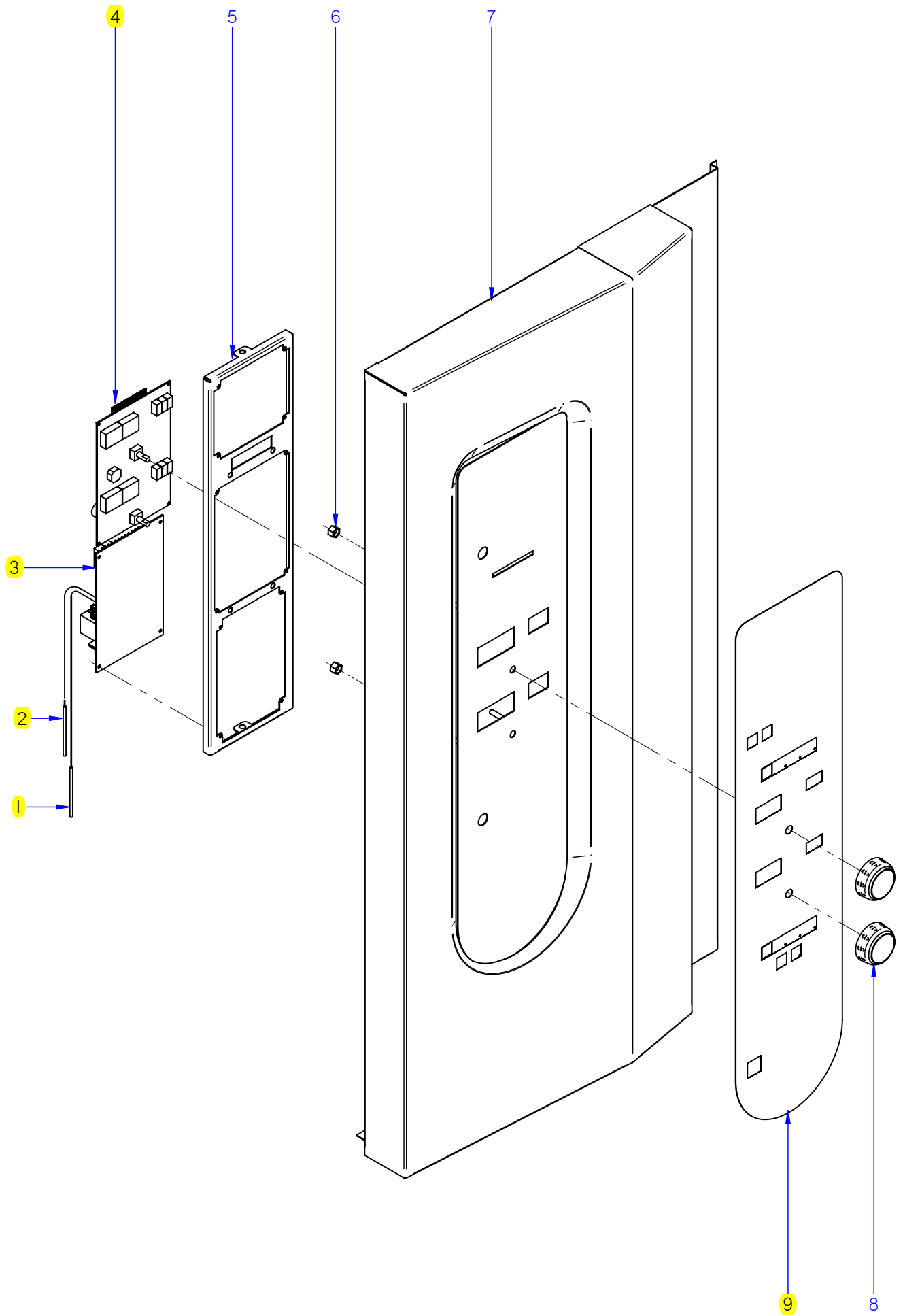

ITEM MARCADO EN COLOR = REPUESTO RECOMENDADO
 COLOURED ITEM = RECOMMENDED SPARE PART

N plano	Firma	Fecha	Aparato	CONJUNTO ELECTRICO PORTAMANDOS	Lamina	Fagor Industrial S.Coop. FAGOR
C-2423	<i>[Signature]</i>	2009-09	HORNOS COE-102		8	Oñate

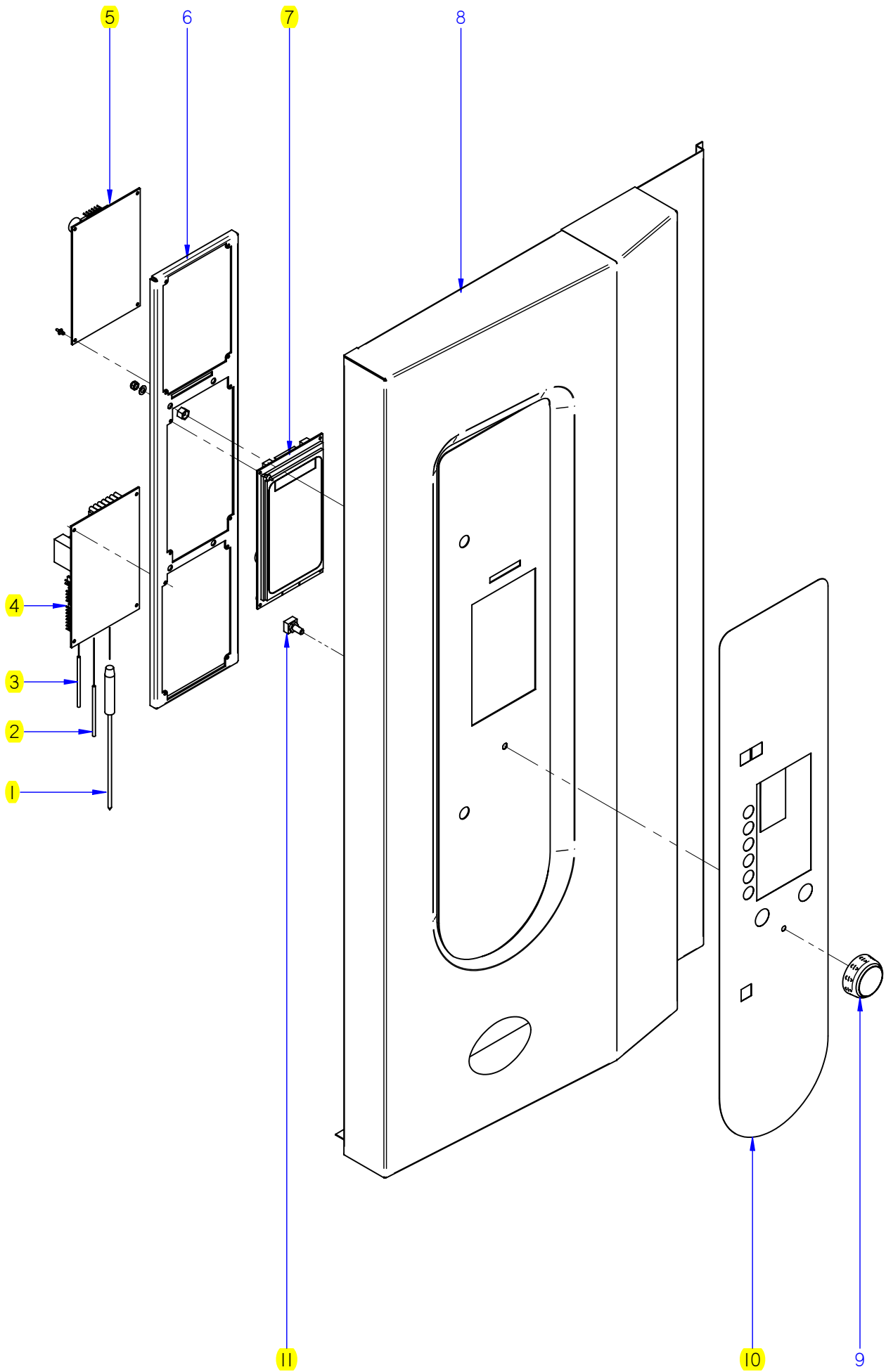

ITEM MARCADO EN COLOR = REPUESTO RECOMENDADO
 COLOURED ITEM = RECOMMENDED SPARE PART

N plano	Firma	Fecha	Aparato	CONJUNTO ELECTRICO PORTAMANDOS	Lamina	Fagor Industrial S.Coop. FAGOR
C-2424	<i>[Signature]</i>	2009-09	HORNOS VE-102		9	Oñate

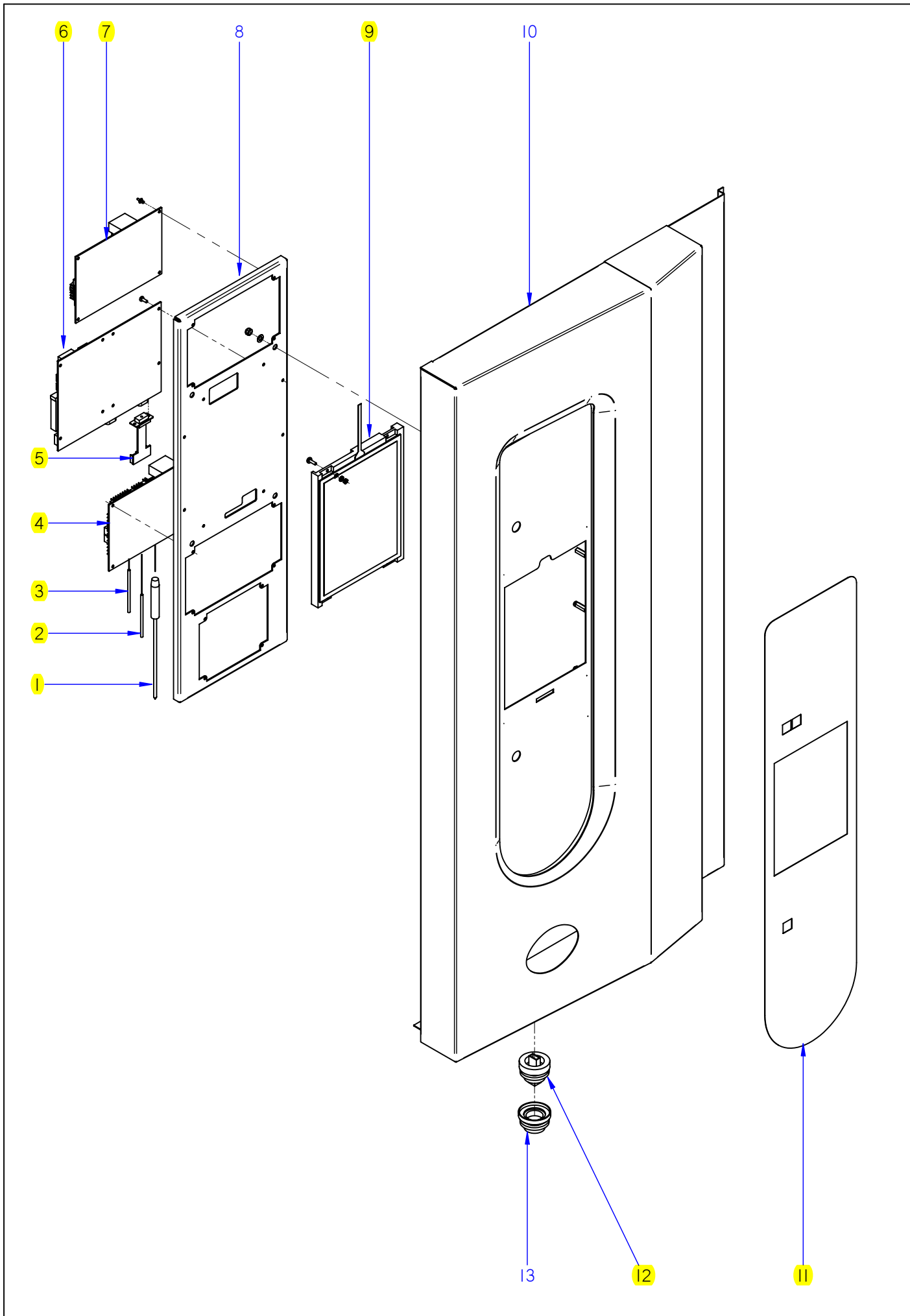

ITEM MARCADO EN COLOR = REPUESTO RECOMENDADO
 COLOURED ITEM = RECOMMENDED SPARE PART

N plano C-2425	Firma <i>[Signature]</i>	Fecha 2009-09	Aparato CONJUNTO ELECTRICO PORTAMANDOS HORNOS VPE-102	Lamina 10	Fagor Industrial S.Coop. FAGOR Oñate
--------------------------	-----------------------------	-------------------------	--	---------------------	--

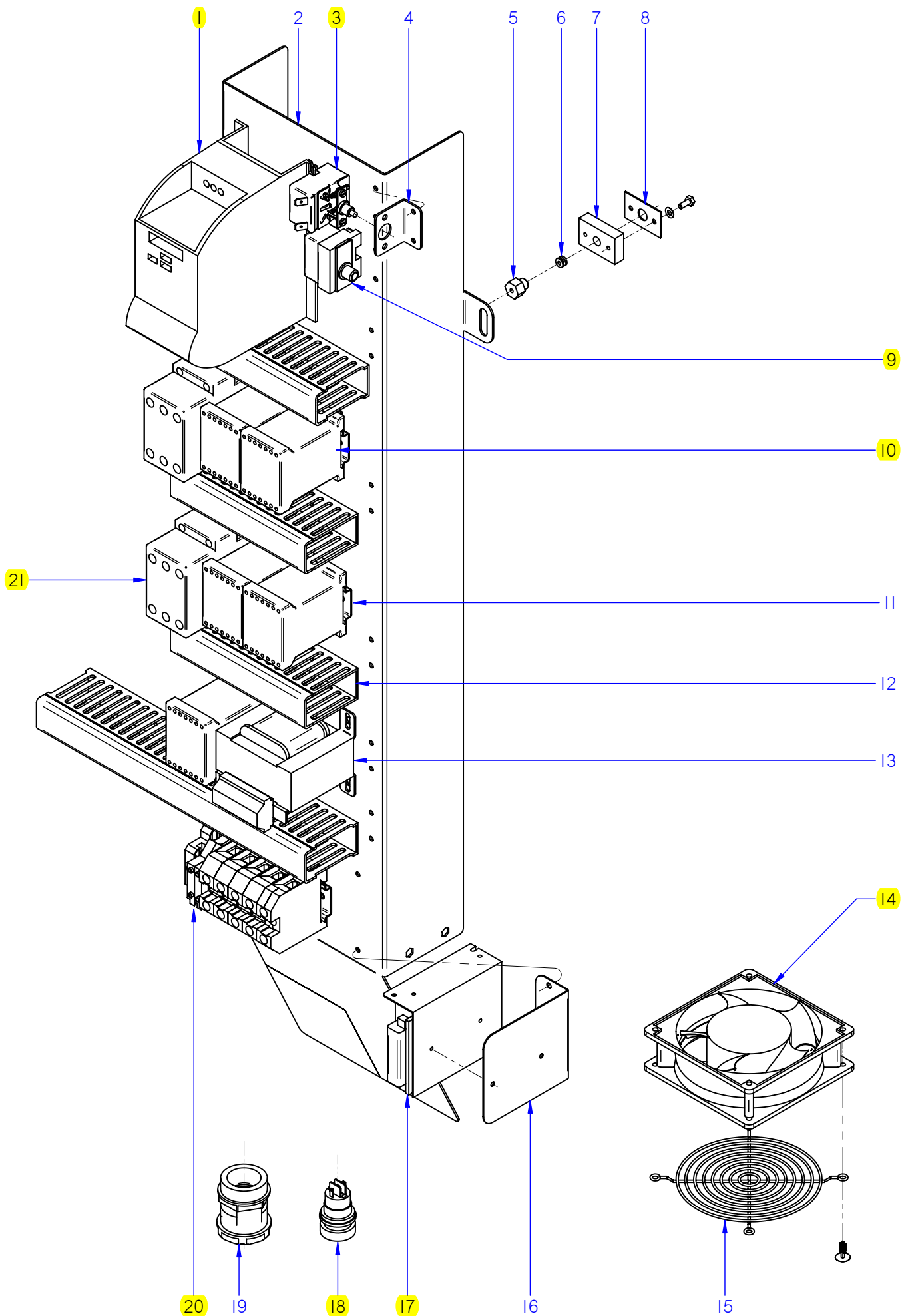

ITEM MARCADO EN COLOR = REPUESTO RECOMENDADO
 COLOURED ITEM = RECOMMENDED SPARE PART

N plano	Firma	Fecha	Aparato	CUADRO ELECTRICO	Lamina	Fagor Industrial S.Coop. FAGOR
C-2426	<i>[Signature]</i>	2009-09	HORNOS COE / VE / VPE-102		11	Oñate

MOD.		HORNOS / OVEN		ZONA		CUADRO ELECTRICO / ELECTRIC PANEL		PLANO		C-2426	
ITEM	CODIGO	DENOMINACION	TEXTO	COE-102	VE-102	VPE-102					NOTAS
1	T323037000	VARIADOR FRECUENCIA SIE 0,37	FREQUENCY VARIATOR SIE 0.37	1	1	1					
	Q232020000	ARANDELA A4	WASHER A.5	2	2	2					
	Q242020000	ARANDELA ABANICO A4 A.304	FAN SHAPED WASHER A.4	2	2	2					
	Q032021000	TORNILLO ALOMADO M4X1C	CURVED SCREW M.4x10	2	2	2					
2	T613007000	CHAPA CUADRO ELEC 10/21	SQUARE PLATE	1	1	1					
	Q221341000	REMACHE EXAGONAL M4	HEXAGONAL RIVET M.4	6	6	6					
	Q221342000	REMACHE EXAGONAL M5	HEXAGONAL RIVET M.5	2	2	2					
	Q232030000	ARANDELA A5	WASHER A.5	2	2	2					
	Q242030000	ARANDELA ABANICO A5 A.304	FAN SHAPED WASHER A.5	2	2	2					
	Q012032000	TORNILLO EXAGONAL M5x15 A304	HEXAGONAL SCREW M.5x15	2	2	2					
	Q232040000	ARANDELA A6	WASHER A.6	1	1	1					
	Q242040000	ARANDELA ABANICO A6 A.304	FAN SHAPED WASHER A.6	1	1	1					
	Q162040000	TUERCA EXAGONAL M6	HEXAGONAL NUT M.6	1	1	1					
3	T303009000	TERMOSTATO LIMITADOR	THERMOSTAT LIMITER	1	1	1					
4	R343039000	SOPORTE TERMOS VAPOR	THERMOSTAT SUPPORT	1	2	2					
	Q412002000	REMACHE AVINOX Ø4x10MM	TUBULAR RIVET 4x7,5	2	4	4					
5	R662629000	RACORD CIERRE SONDA	PROBE CLOSING ADAPTOR	2	2	2					
6	R662652000	BICONO CIERRE SONDA	PROBE CLOSING BICONE	2	2	2					
7	T112625000	BASE CIERRE SONDA	FIXING CORE PROBE	2	2	2					
8	R692812000	JUNTA PASAMUROS SIMPLE	FEEDTHROUGH SEAL	2	2	2					
	Q232020000	ARANDELA A4	WASHER A.4	4	4	4					
	Q012021000	TORNILLO EXAGONAL M4X10	HEXAGONAL BOLT M4X10	4	4	4					
9	Z953035000	TERMOSTATO LIMITADOR AVISO	LIMITER THERMOSTAT WARNIN	-	1	1					
	Z953041000	TUERCA M.10x1 EGO 00.00600.075	NUT M.10x1 EGO 00.00600.075	1	2	2					
10	Z203050000	CONTAC. SIRIUS 3R 230V.50-60	SIRIUS 3R 230V.50-60 CONTAC.	5	5	5					
11	Z123018000	GUIA CONTACTOR L-55	CONTACTOR GUIDE L-55	1	1	1					
	Z103084000	GUIA CONTACTOR L-138	CONTACTOR GUIDE L-138	2	2	2					
	R663055000	GUIA CONTACTOR L-120	CONTACTOR GUIDE L=120	1	1	1					
12	3715520000	CANALETA UNEX 60.30.77 / 0.12	PIPING UNEX 60.30.77 / 0.12	5	5	5					
	Q412002000	REMACHE AVINOX Ø4x10MM	TUBULAR RIVET 4x7,5	22	26	26					
13	R503005000	TRANSFORMADOR 230/12-0-12,0-1	TRANSFORMER 230/12-0-12,0-1	1	1	1					

MOD.		HORNOS / OVEN		ZONA	VARIOS / MISCELLANEOUS			PLANO	
ITEM	CODIGO	DENOMINACION	TEXTO	COE-102	VE-102	VPE-102			
	T906501000	MANUAL DE INSTRUCCIONES COE	INSTRUCTIO. BROCHURE COE	1	-	-			
	T916501000	MANUAL DE INSTRUCC. VE	INSTRUC. BROCHURE VE SPA	-	1	-			
	T926501000	MANUAL DE INSTRUCC. VPE	INSTRUC. BROCHURE VPE SPA	-	-	1			
	T326507000	MANUAL DE INSTRUCC. VPE ING.	INSTRUC. BROCHURE VPE ENG	1	1	1			
	T326506000	MANUAL DE INSTRUCC. VPE FRA.	INSTRUC. BROCHURE VPE FRE	1	1	1			
	T326501000	MANUAL DE INSTRUCC. VPE ALE.	INSTRUC. BROCHURE VPE GER	1	1	1			
	T326508000	MANUAL DE INSTRUCC. VPE ITA.	INSTRUC. BROCHURE VPE ITA	1	1	1			
	T603001000	ESQUEMA TEORICO CONC. 10/21	THEORETICAL DIAGRAM 10/21	1	-	1			PLANO HC-80790
	T613001000	ESQUEMA TEORICO VISUAL 10/21	THEORETICAL DIAGRAM 10/21	-	1	-			PLANO HC-80798
	T603002000	PLANO DE MONTAJE CONC. 10/21	ASSEMBLY PLAN CONC. 10/21	1	-	1			PLANO HC-80791
	T613002000	PLANO DE MONTAJE VISUAL 10/21	ASSEMBLY PLAN CONC. 10/21	-	1	-			PLANO HC-80799
	T303031000	CABLEADO LUZ INTERIOR	INTERIOR LIGHT WIRING	1	1	1			
	T903006000	CABLEADO COMUNICACIÓN BMF	COMMUNICATION WIRING BMF	1	2	2			
	T603003000	INSTAL. ELEC. CONCEPT 10/21	ELEC. INSTAL. CONCEPT 10/21	1	-	-			
	T613003000	INSTAL. ELEC. VISUAL E 10/21	ELEC. INSTALL. VISUAL E 10/21	-	1	1			
	T603004000	CABLEA. FUERZA CONCEPT 10/21	POWER WIRE . CONCEPT 10/21	1	-	-			
	T613004000	CABLEADO FUERZA VISUAL E 10/21	POWER WIRE . VISUAL E 10/21	-	1	1			
	T603005000	CABLEADO RESI. CONCEPT 10/21	RESISTOR WIRING CONCEPT	1	-	-			
	T613005000	CABLEADO RESIS. VISUAL E 10/21	RESISTOR WIRING VISUAL	-	1	1			
	T913006000	CAB CIRCUIT PORTAMANDOS VIS.	VIS. CONTROL HOLDER CIRCUIT	-	1	-			
	T603006000	CABLEADO VARIADOR CONCEPT	CONCEPT VARIATOR WIRING	1	1	1			
	T333009000	CABLEADO LAVADO HEP	WASH WIRING HEP	-	-	1			
	T553006000	CABLEADO FUENTE ALIMENTAC.	POWER SUPPLY WIRING	-	-	1			
	T523003000	CABL ADAPT TFT VISUAL+ x/21	ADAPT. WIRING TFT VISUAL	-	-	1			
	T723008000	CABLE USB VISUAL PLUS	VISUAL PLUS USB CABLE	-	-	1			

COE 102

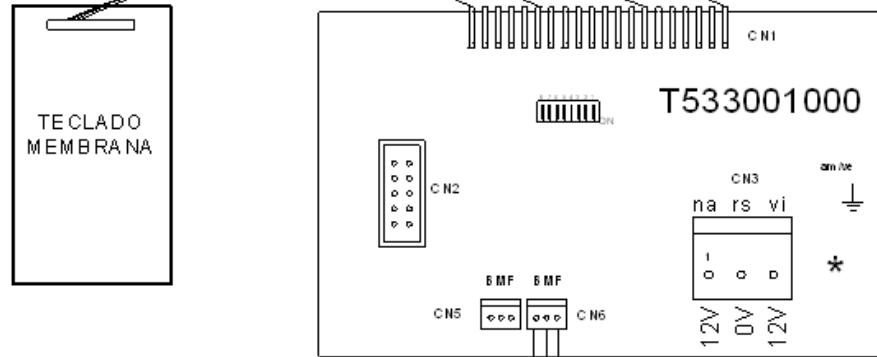

3N-50/60Hz 380/415V

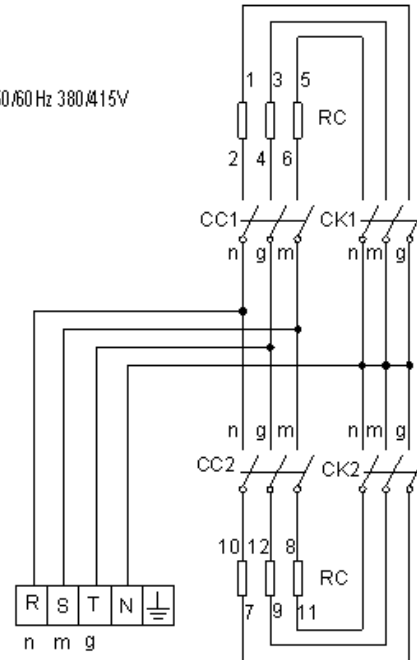

3-50,60Hz 220V

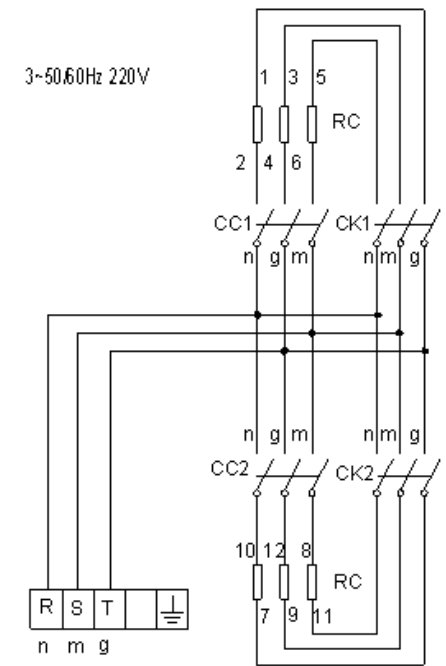

* Connection to transformer

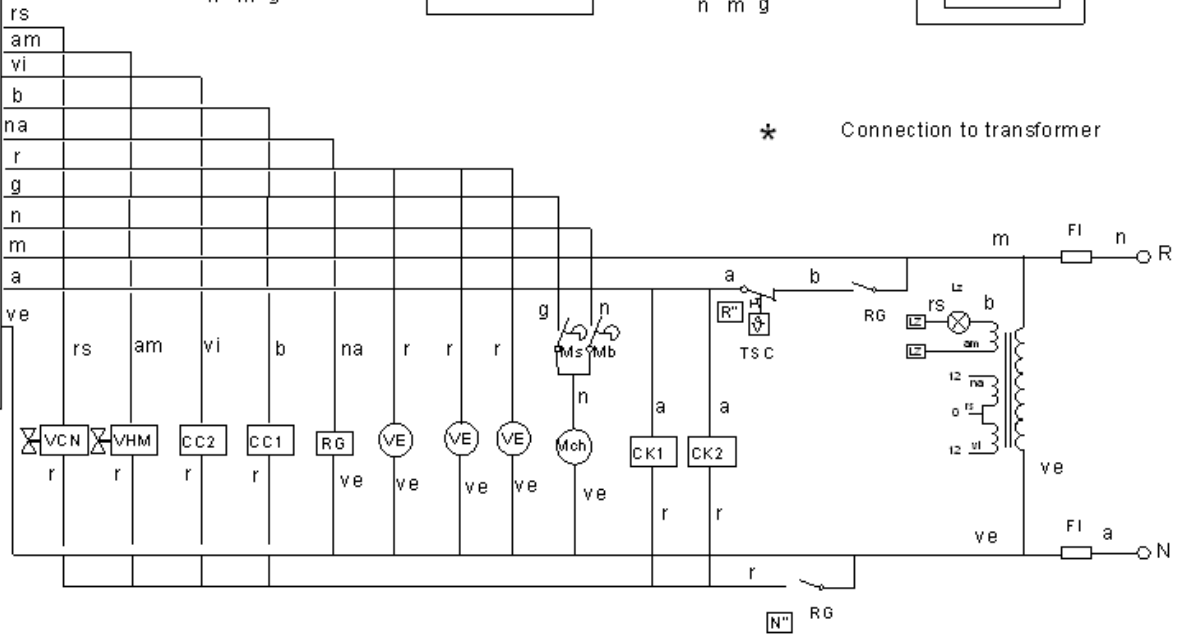
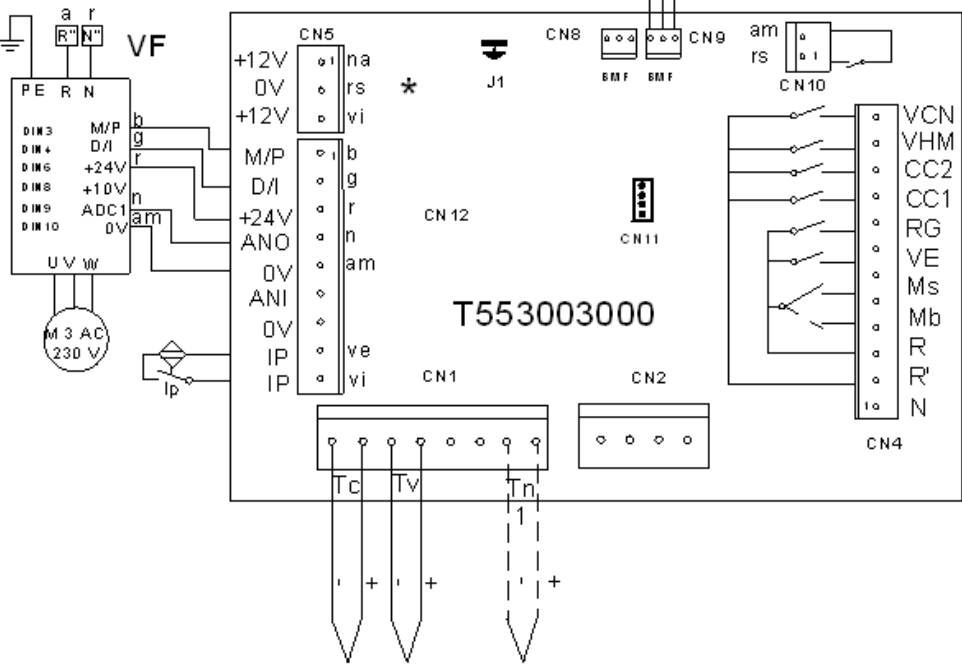

T603001000

VE 102

3N-50/60 Hz 380/415V

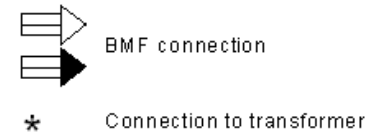
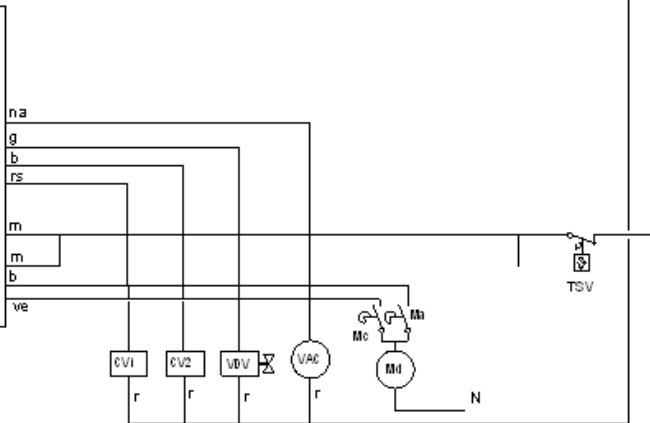
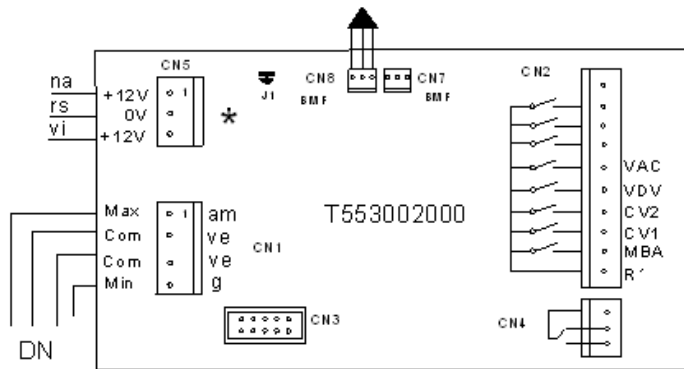
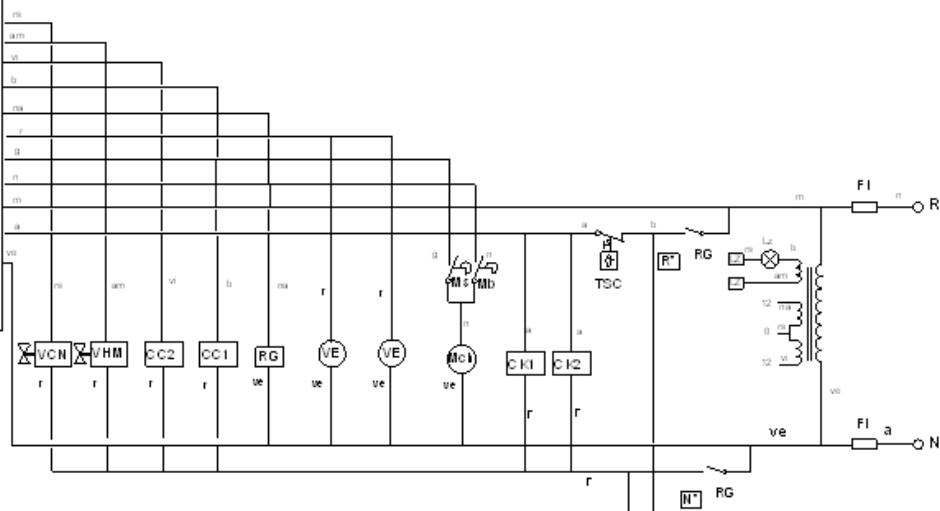
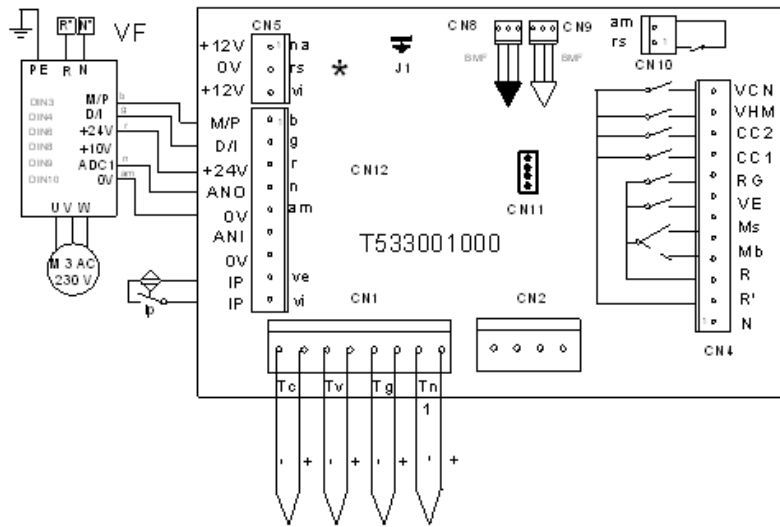
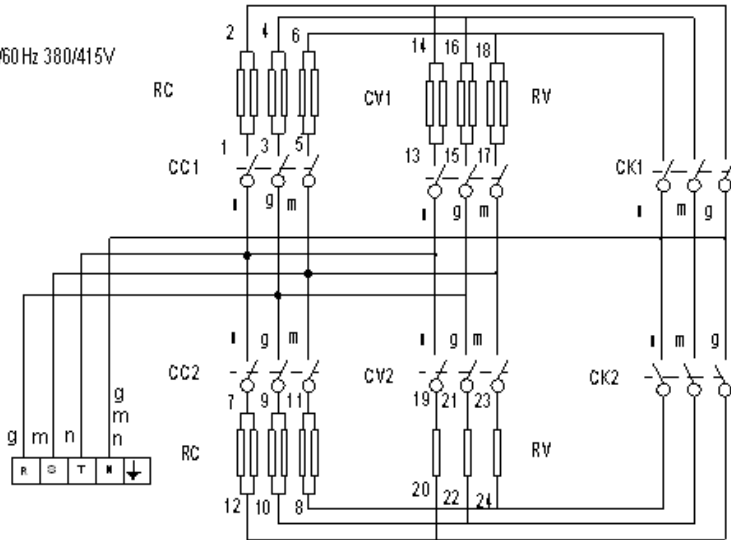
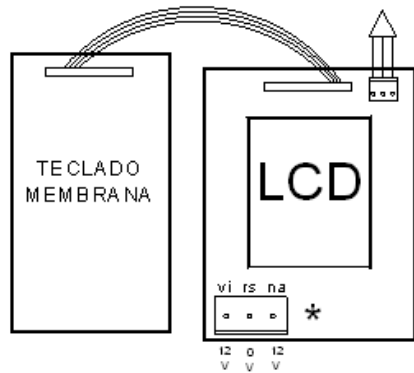

T613001000

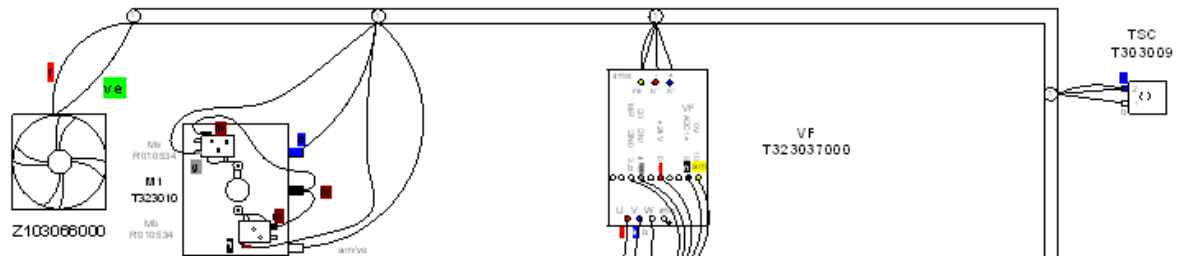

Eskema teorikoa	T603001
1	T603003
2	T603006
3	T603004
4	T603005
5	T303031
6	T903006

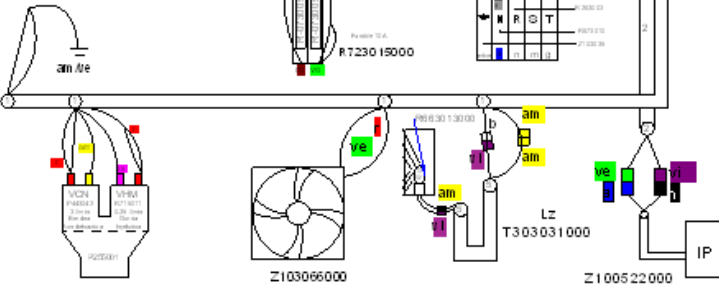
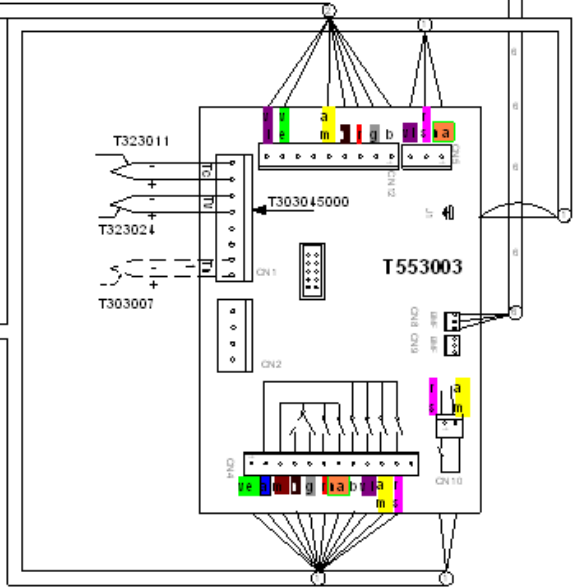
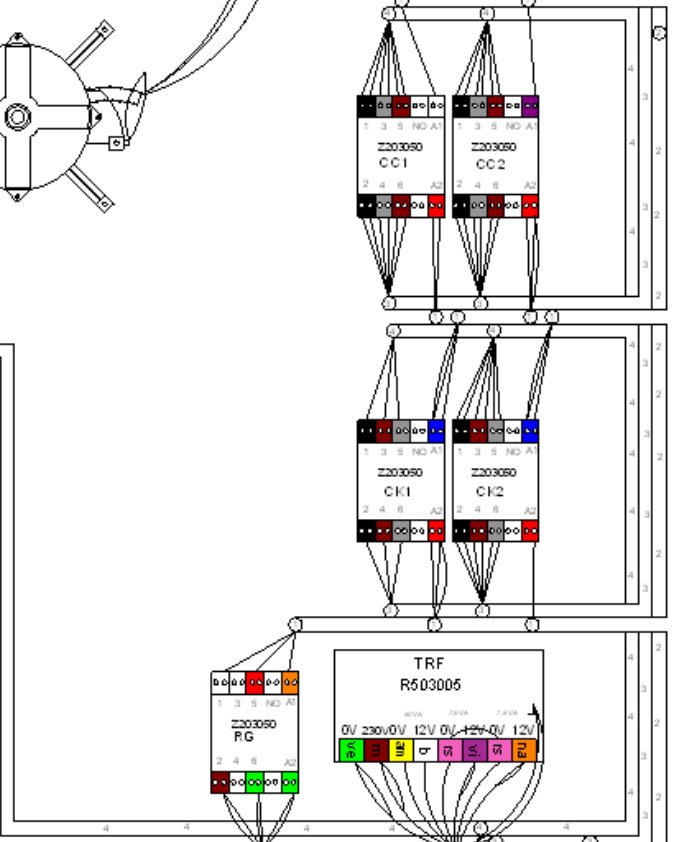
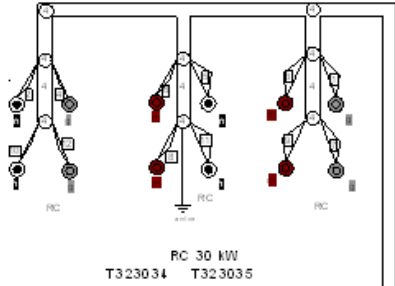
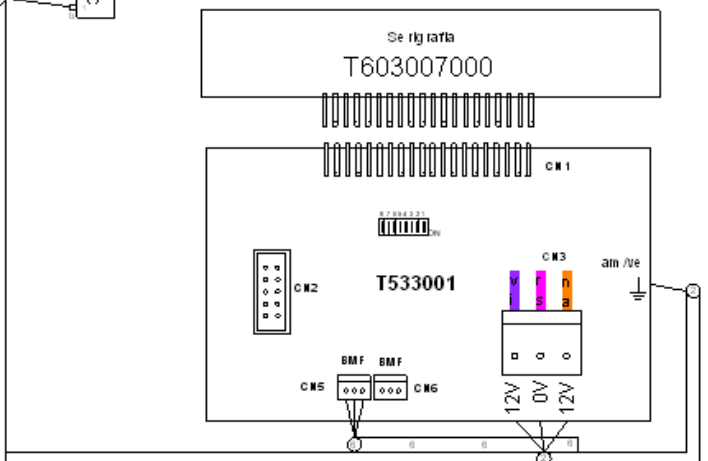
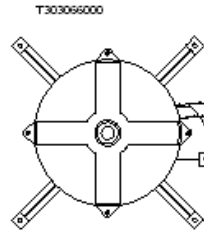

Muntzeko planoak: COE 102				T603002000	
Zk./Nº	Plaza	Cart.	Materia/Material	Das. zk/Nº Clas	Ganaiak/abakoa/Tratamiento
Zk./Nº	Abakoa/Matritzak/serie		Prok. proposakua/Propuesta de	Data/Fecha	Perda sistema/ Tolerantzia generalak
-	-	-	-	-	+5 s [] 50 + 100 s []
-	-	-	-	-	5 + 20 s [] >100 s []
-	-	-	-	-	20 + 50 s [] 0 s []
Merkatu/Olagatu: s.azkaracel 2009-01-19 Proiektatza/Proyectado: s.azkaracel 2009-01-19 Egindakoa/Completado: s.azkaracel 2009-01-19				FAGOR Fagor Industrial Korp. EIk. Magalua	
Eskala/Escala:				LABEAK Plano Zk./Plano N° HC-80791	
-				- Zk. ord. de	
-				- Zk. grafik. ord.	

Eskema teoriko a	T61 3001
1	T613003
2	T603006
3	T613004
4	T613005
5	T303031
6	T903006
7	T913006
8	T903006

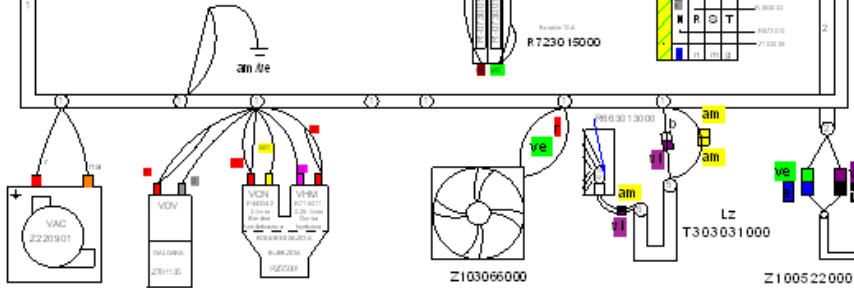
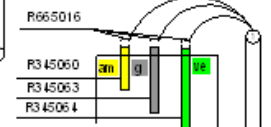
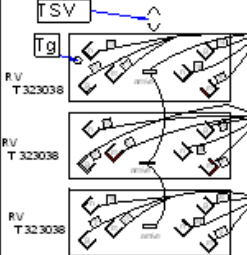
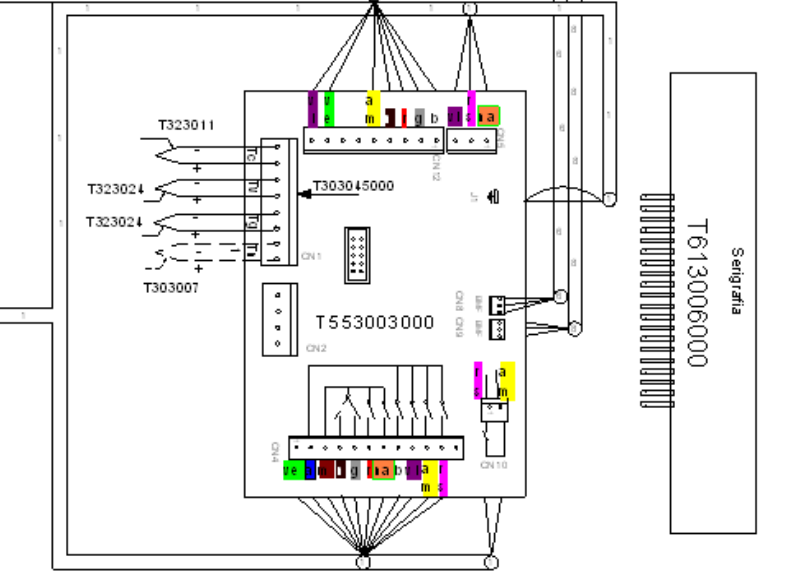
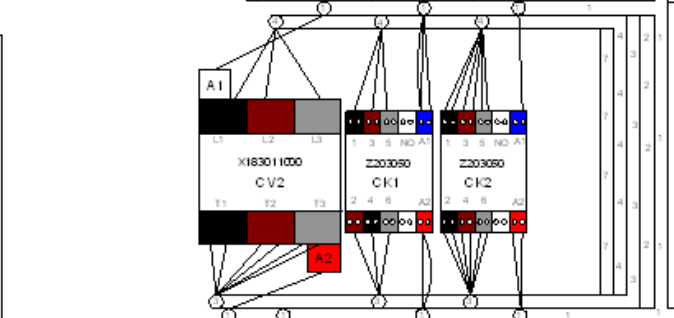
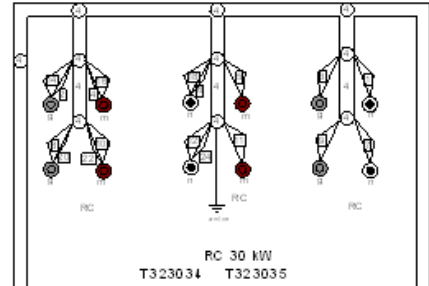
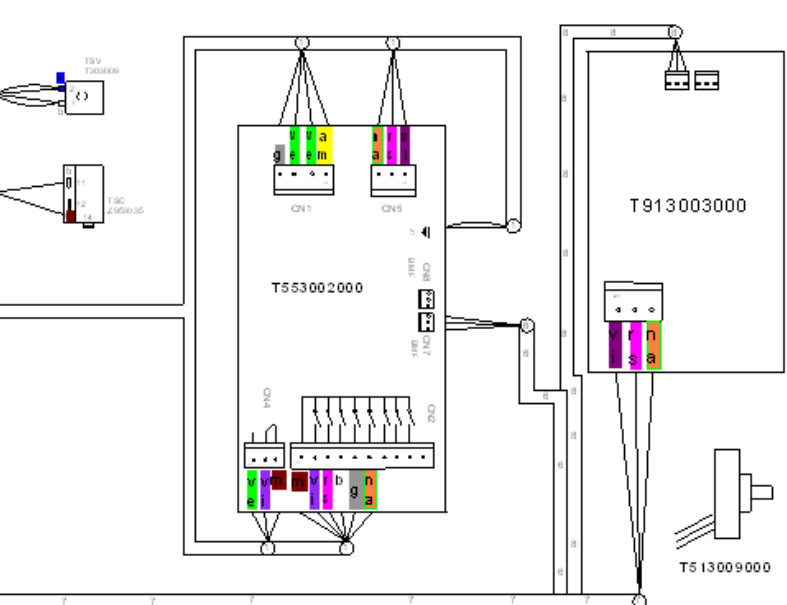
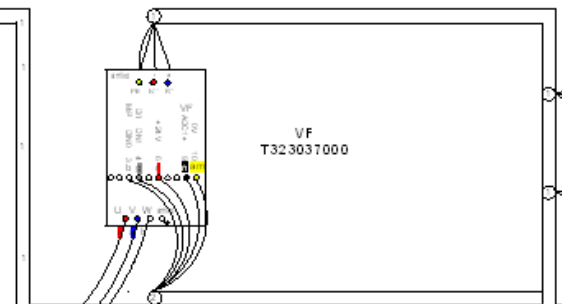
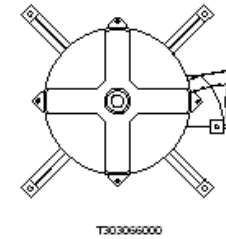
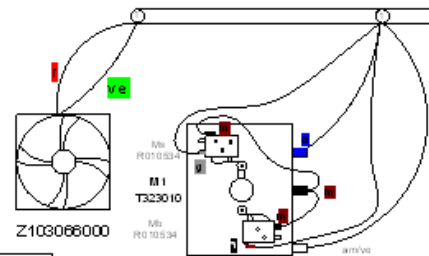

Muntjeko plano: VE 102				T618002000	
Zk./N°	Plaza	Cart.	Materia/Waterial	Das. z/N° Clas	Ganaiak abakoa/Tratamiento
Zk./N°	Abakoa/Matricioa		Desk. proposakua/Propuesta de	Data/Fecha	Perda abakoa/Tolerancia ganaiak
-	-	-	-	-	Tolerancia ganaiak
-	-	-	-	-	+5 s [mm] 50 + 100 s [mm]
-	-	-	-	-	5 + 25 s [mm] +100 s [mm]
-	-	-	-	-	25 + 50 s [mm] 0 s [mm]
Maratua/Olagatu s. en/fecha 2019-01-19				FAGOR Fagor Industrial Korp. E.L. Mugatu	
Proiektatza/Proyector s. en/fecha 2019-01-19				Ganaiak perdia Mecanizado superficial	
Egindutako/Completado s. en/fecha 2019-01-19				Plano Zk./Plano N° LABEAK HC-807.99	
Eskala/Escala				Plano hau ez da datu orria, ez denbela, gero bainirik gabek.	