

**Hornos Mixtos
Fours Mixtes
Combi Ovens
HeiBluftdämpfer
Forno Misti**

Modelos:

**HME-6/11
HME-10/11
HME-10/21
HME-2-10/11**

**VECE-6/11
VECE-10/11
VECE-10/21
VECE-2-10/11**

**HMP-6/11
HMP-10/11
HMP-10/21
HMP-2-10/11**

**VECP-6/11
VECP-10/11
VECP-10/21
VECP-2-10/11**

**THCV-6/11
THCV-10/11
THCV-10/21P
THCV-2-10/11P**

Noviembre 2003 November



Fagor Industrial

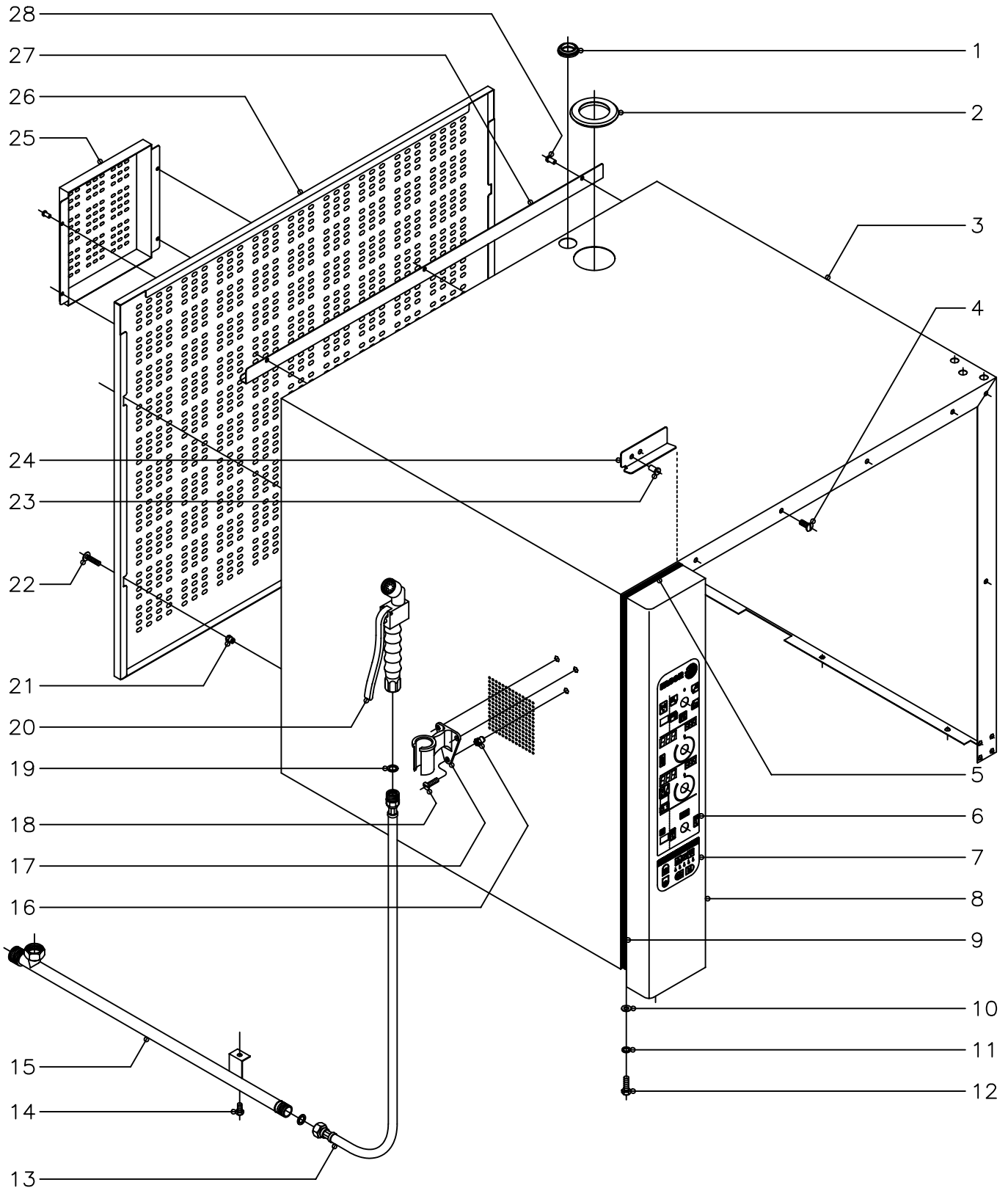

N plano
C-1451

Firma
[Signature]

Fecha
11-2003

Aparato
MUEBLE
HORNOS MIXTOS ELECTRONICOS

Lamina
1

Fagor Industrial S.Coop. **FAGOR**
Onate

MOD.		HORNOS MIXTOS ELECTRONICOS		ZONA		MUEBLE						PLANO		C-1451
ITEM	CODIGO	DENOMINACION	TEXTO	HME-6/11	HME-10/11	HME-10/21	HME-2-10/11	HMP-6/11	HMP-10/11	HMP-10/21	HMP-2-10/11		NOTAS	
1	N503017	Soporte termostato		1	1	1	1	1	1	1	1		Pasamuros chimenea	
2	R662813	Pasamuros chimenea		1	1	1	1	1	1	1	1			
3	R662819	Cuerpo exterior de horno 6/11		1	-	-	-	1	-	-	-			
3	R672816	Cuerpo exterior de horno 10/11		-	1	-	-	-	1	-	-			
3	R682812	Cuerpo exterior de horno 10/21		-	-	1	1	-	-	1	1			
4	Q152017	Tornillo amarre M-6x13		6	6	6	6	6	6	6	6			
5	3715400	Junta panel portamandos L=130		1	1	1	1	1	1	1	1			
6	R663009	Serigrafia superior (controlador)		1	-	-	-	1	-	-	-			
6	R673000	Serigrafia superior (controlador)		-	1	1	1	-	1	1	1			
7	R663014	Serigrafia inferior (neutra)		1	1	1	1	-	-	-	-			
7	R663010	Serigrafia inferior (programador)		-	-	-	-	1	1	1	1			
8	R662821	Panel portamandos 6/11		1	-	-	-	1	-	-	-			
8	R672818	Panel portamandos 10/11 y 10/21		-	1	1	1	-	1	1	1			
9	3715400	Junta panel portamandos L=530		2	-	-	-	2	-	-	-			
9	3715400	Junta panel portamandos L=770		-	2	2	2	-	2	2	2			
10	Q232040	Arandela plana A-6		2	2	2	2	2	2	2	2			
11	Q262040	Arandela muelle A-6		2	2	2	2	2	2	2	2			
12	Q012042	Tornillo exagonal M-6x15		2	2	2	2	2	2	2	2			
13	R095006	Flexible de ducha		1	1	1	1	1	1	1	1			
14	Q012042	Tornillo exagonal M-6x15		1	1	1	1	1	1	1	1			
15	R675002	Suplemento ducha 6/11		1	1	-	-	1	1	-	-			
15	R685003	Suplemento ducha		-	-	1	1	-	-	1	1			
16	Q221342	Remache exagonal M-4		3	3	3	3	3	3	3	3			
17	R095007	Soporte de ducha		1	1	1	1	1	1	1	1			
18	Q042022	Tornillo avellanado M-4x15		3	3	3	3	3	3	3	3			
19	Q306024	Arandela junta Ø18xØ12,5x1,5		2	2	2	2	2	2	2	2			
20	R095005	Cuerpo de ducha		1	1	1	1	1	1	1	1			
21	Q221342	Remache exagonal M-5		4	4	4	4	4	4	4	4			
22	Q152038	Tornillo amarre M-5x30		4	4	4	4	4	4	4	4			

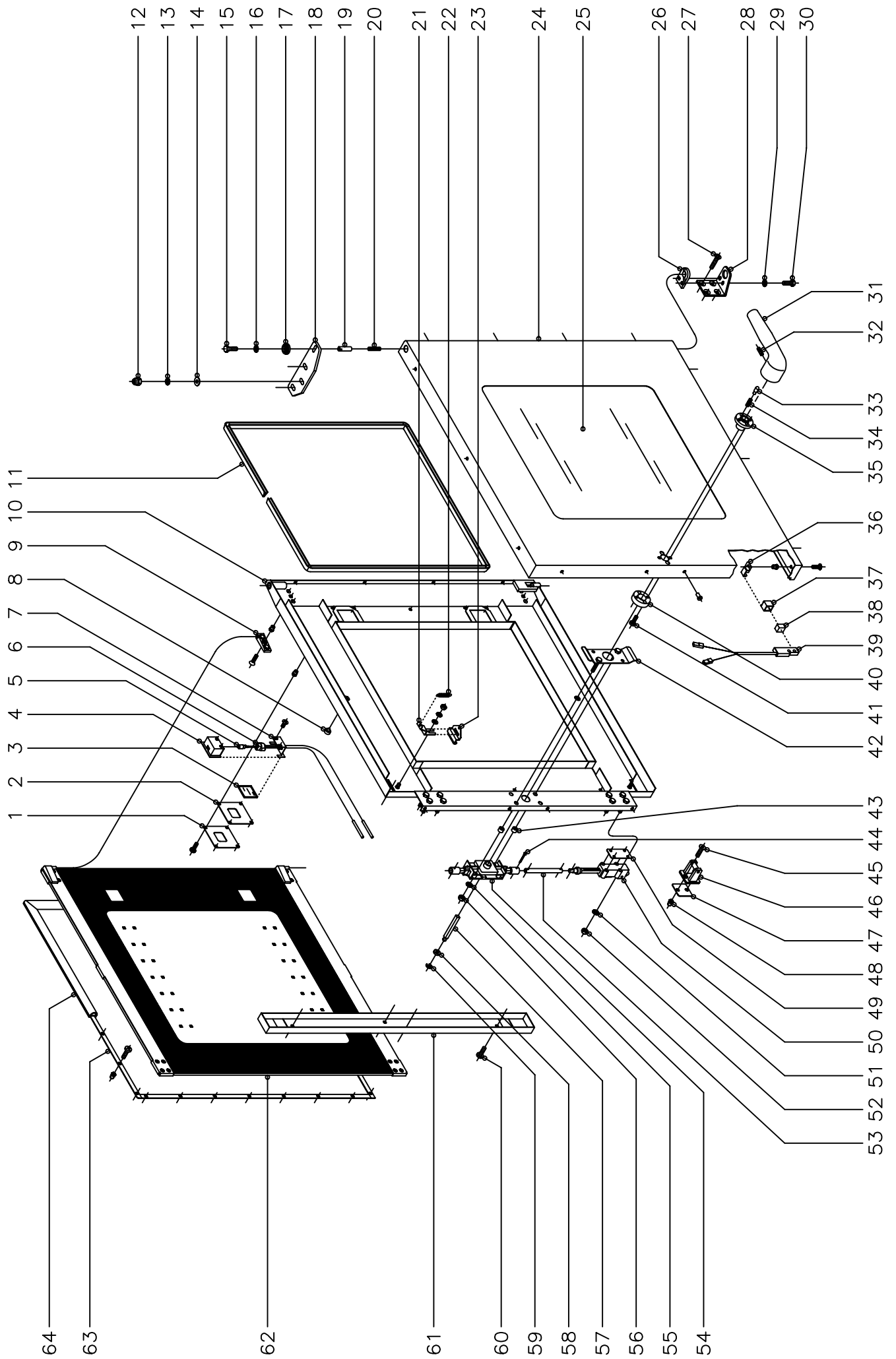

N plano
C-1452

Firma
[Signature]

Fecha
11-2003

Aparato
PUERTA
HORNOS MIXTOS ELECTRONICOS

Lamina
2

Fagor Industrial S.Coop. **FAGOR**
Onate

MOD.		HORNOS MIXTOS ELECTRONICOS		ZONA	PUERTA								PLANO	C-1452			
ITEM	CODIGO	DENOMINACION	TEXTO	HME-6/11	HMP-6/11	HME-10/11	HMP-10/11	HME-10/21	HMP-10/21	HME-2-10/11	HMP-2-10/11						NOTAS
	1100002594	KIT Puerta completa 6/11		1	-	-	-										
	1100002595	KIT Puerta completa 10/11		-	1	-	-										
	1100002596	KIT Puerta completa 10/21		-	-	1	1										
1	R670608	Tapa cierre lampara		2	2	2	2										
	Q152004	Tornillo aplastado M-5x13		8	8	8	8										
	Q222011	Remache exagonal M-5		8	8	8	8										
2	R670609	Junta cierre lampara		2	2	2	2										
3	R670618	Cristal de lampara		2	2	2	2										
4	R670610	Deflector de lampara		2	2	2	2										
5	R663013	Lampara 10 W. 12 V.		2	2	2	2										
6	R663058	Portalamparas		2	2	2	2										
7	R670611	Suplemento deflector		2	2	2	2										
	Q042031	Tornillo avellanado M-5x10		4	4	4	4										
8	R670617	Tope cristal interior		6	6	6	6										
9	R670615	Base de bisagra		2	2	2	2										
	Q042032	Tornillo avellanado M-5x15		2	2	2	2										
	Q222011	Remache exagonal M-5		2	2	2	2										
10	T080500	Contrapuerta completa 6/11		1	-	-	-										
10	T110500	Contrapuerta completa 10/11		-	1	-	-										
10	T120500	Contrapuerta completa 10/21		-	-	1	1										
11	3715200	Junta cristal L=1700		1	-	-	-										
11	3715200	Junta cristal L=2000		-	1	-	-										
11	3715200	Junta cristal L=2300		-	-	1	1										
12	Q212051	Tuerca sombrerete M-8		3	3	3	3										
13	Q242050	Arandela abanico A-8		3	3	3	3										
14	Q302025	Arandela plana Ø8,4xØ20x1,5		3	3	3	3										
15	Q012042	Tornillo exagonal M-6x15		1	1	1	1										
16	Q242040	Arandela abanico A-6		1	1	1	1										

MOD.		HORNOS MIXTOS ELECTRONICOS		ZONA		PUERTA				PLANO		C-1452	
ITEM	CODIGO	DENOMINACION	TEXTO	HME-6/11	HMP-6/11	HME-10/11	HMP-10/11	HME-10/21	HMP-10/21	HME-2-10/11	HMP-2-10/11		NOTAS
17	R662807	Arandela amarre puerta		1		1		1		1			
18	T130500	Bisagra superior		1		1		1		1			
19	R660534	Eje superior		1		1		1		1			
20	Z850519	Resorte		1		1		1		1			
21	R670612	Base de pestillo		2		2		2		2			
	Q302022	Arandela plana Ø16xØ6x1,2		2		2		2		2			
	Q242040	Arandela abanico A-6		2		2		2		2			
	Q162040	Tuerca exagonal M-6		2		2		2		2			
22	R660605	Muelle tensor pestillo		2		2		2		2			
23	R670613	Pestillo sujecion cristal interior		2		2		2		2			
24	R660600	Panel puerta 6/11		1		-		-		-			
24	R670600	Panel puerta 10/11		-		1		-		-			
24	R680600	Panel puerta 10/21		-		-		1		1			
	Q412002	Remache tubular Ø4x7,5		14		14		14		14			
25	R660606	Cristal exterior 6/11		1		-		-		-			
25	R670625	Cristal exterior 10/11		-		1		-		-			
25	R680609	Cristal exterior 10/21		-		-		1		1			
26	R660549	Guia eje inferior		1		1		1		1			
27	Q062040	Tornillo avellanado M-6x16		4		4		4		4			
28	R660551	Bisagra inferior		1		1		1		1			
29	Q242040	Arandela abanico A-6		2		2		2		2			
30	Q012041	Tornillo exagonal M-6x10		2		2		2		2			
31	T130502	Manilla		1		1		1		1			
32	Q132042	Varilla roscada M-6x15		1		1		1		1			
33	T130507	Piton enganche		2		2		2		2			
34	T130506	Resorte		2		2		2		2			
35	T130515	Guia manilla		1		1		1		1			
36	T130513	Soporte iman		1		1		1		1			
37	Z200507	Protector iman		1		1		1		1			

MOD.		HORNOS MIXTOS ELECTRONICOS		ZONA	PUERTA								PLANO	C-1452			
ITEM	CODIGO	DENOMINACION	TEXTO	HME-6/11	HMP-6/11	HME-10/11	HMP-10/11	HME-10/21	HMP-10/21	HME-2-10/11	HMP-2-10/11						NOTAS
38	Z200506	Iman		1		1		1		1							
39	Z100522	Interruptor magnetico		1		1		1		1							
40	T130514	Soporte resortes		1		1		1		1							
41	Q032032	Tornillo alomado M-5x15		2		2		2		2							
42	T130511	Suplemento fijacion cerradura		1		1		1		1							
43	Z608410	Casquillo		2		2		2		2							
44	Q352001	Pasador de aletas Ø2x15		4		4		4		4							
45	Q042043	Tornillo avellanado M-6x20		4		4		4		4							
46	R260545	Enganche		2		2		2		2							
47	R660538	Calzo de enganche		4		4		4		4							
48	Q221343	Remache exagonal M-6		4		4		4		4							
49	T080503	Suplemento elemento cierre		6		6		6		6							
50	T080504	Elemento de cierre		2		2		2		2							
51	Q262040	Arandela muelle A-6		8		8		8		8							
52	Q162040	Tuerca exagonal M-6		8		8		8		8							
53	R020502	Tubo alargadera		-		2		2		2							
54	T130509	Mecanismo de cierre		1		1		1		1							
55	Q262040	Arandela muelle A-6		2		2		2		2							
56	Q162040	Tuerca exagonal M-6		2		2		2		2							
57	T130508	Eje de manilla		1		1		1		1							
58	T130505	Casquillo		1		1		1		1							
59	Q271033	Arandela de seguridad Ø6		1		1		1		1							
60	Q032031	Tornillo alomado M-5x10		2		2		2		2							
60	Q032021	Tornillo alomado M-4x10		2		2		2		2							
61	T080502	Tapa cierre puerta		1		-		-		-							
61	T110502	Tapa cierre puerta		-		1		1		1							
62	1100002806	KIT Cristal interior completo	6/11	1		-		-		-							
62	1100002807	KIT Cristal interior completo	10/11	-		1		-		-							
62	1100002808	KIT Cristal interior completo	10/21	-		-		1		1							

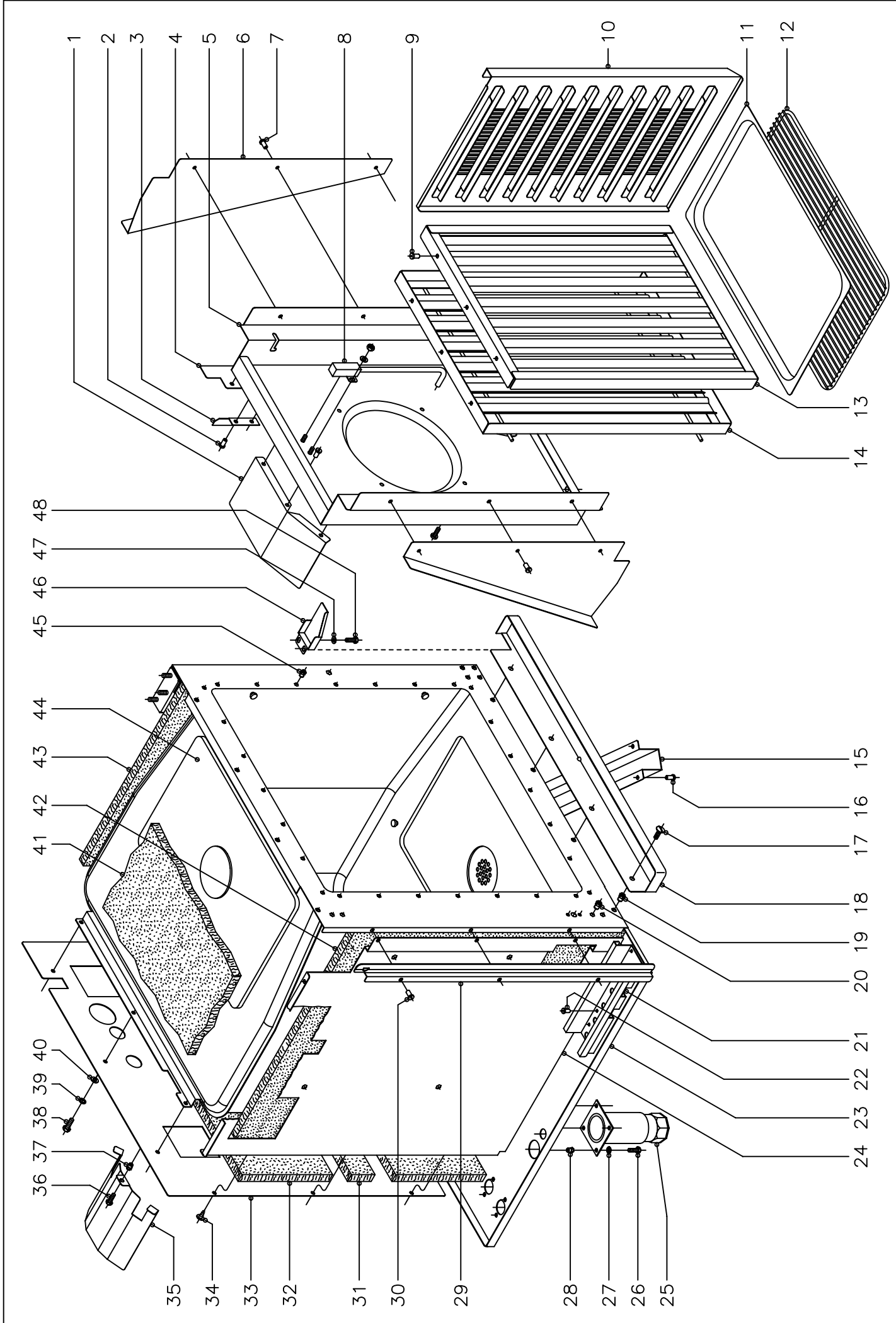

N plano C-1453	Firma 	Fecha 11-2003	Aparato MUEBLE INTERIOR HORNOS MIXTOS ELECTRONICOS	Lamina 3	Fagor Industrial S.Coop. FAGOR Oñate
-------------------	----------------------------------------------------------------------------------------------	------------------	----------------------------------------------------------	-------------	------------------------------------------------

MOD.	HORNOS MIXTOS ELECTRONICOS	ZONA	MUEBLE INTERIOR	PLANO	C-1453
------	-----------------------------------	------	------------------------	-------	---------------

ITEM	CODIGO	DENOMINACION	TEXTO	HME-6/11	HMP-6/11	HME-10/11	HMP-10/11	HME-10/21	HMP-10/21	HME-2-10/11	HMP-2-10/11							NOTAS
1	R682632	Deflector de turbina		-	-	2	2											
	Q412002	Remache tubular Ø 4x7,5		-	-	6	6											
2	Q412002	Remache tubular Ø 4x7,5		4	4	4	4											
3	R292647	Escuadra sujecion cubreventilador		2	2	2	2											
4	R662648	Aleron derecho		1	-	-	-											
s/n	R662647	Aleron izquierdo		1	-	-	-											
	Q412002	Remache tubular Ø 4x7,5		6	-	-	-											
5	R662656	Cubre ventilador		1	-	-	-											
5	R672651	Cubre ventilador		-	1	-	-											
5	R682669	Cubre ventilador		-	-	1	1											
6	R732619	Aleron lateral		-	-	2	2											
7	Q412002	Remache tubular Ø 4x7,5		-	-	6	6											
8	R665020	Tubo inyector		1	-	-	-											
8	R675017	Tubo inyector		-	1	1	1											
	Q232030	Arandela plana A-5		2	2	2	2											
	Q162030	Tuerca exagonal M-5		2	2	2	2											
9	Q412002	Remache tubular Ø 4x7,5		6	6	6	6											
10	R662668	Guia de bandejas derecha		1	-	-	-											
s/n	R662670	Guia de bandejas izquierda		1	-	-	-											
10	T112615	Guia de bandejas derecha		-	1	-	-											
s/n	T112617	Guia de bandejas izquierda		-	1	-	-											
10	T122614	Guia de bandejas derecha		-	-	1	-											
s/n	T122616	Guia de bandejas izquierda		-	-	1	-											
11	R252816	Bandeja 1/1 (530x325x20)		1	1	-	1											
11	R032605	Bandeja 2/1 (530x650x40)		-	-	1	-											
12	R672665	Parrilla 1/1		1	1	-	1											
12	R682676	Parrilla 2/1		-	-	1	-											
13	R662617	Anterior de filtro		1	-	-	-											
13	R092618	Anterior de filtro		-	1	1	1											

MOD.	HORNOS MIXTOS ELECTRONICOS	ZONA	MUEBLE INTERIOR	PLANO	C-1453
------	-----------------------------------	------	------------------------	-------	---------------

ITEM	CODIGO	DENOMINACION	TEXTO	HME-6/11	HMP-6/11	HME-10/11	HMP-10/11	HME-10/21	HMP-10/21	HME-2-10/11	HMP-2-10/11							NOTAS
14	R662622	Posterior de filtro		1	-	-	-											
14	R092621	Posterior de filtro		-	1	1	1											
15	R672804	Cubre desagüe		1	1	-	-											
15	R682805	Cubre desagüe		-	-	1	1											
16	Q412002	Remache tubular Ø 4x7,5		8	8	8	8											
17	Q152017	Tornillo amarre M-6x13		4	4	4	4											
18	T112813	Recoge aguas		1	1	-	-											
18	T122811	Recoge aguas		-	-	1	1											
19	Q221343	Remache exagonal M-6		4	4	4	4											
20	Q221343	Remache exagonal M-6		8	8	8	8											
21	R342821	Guia del cuadro electrico		1	1	1	1											
22	Q412002	Remache tubular Ø 4x7,5		8	8	8	8											
23	R672813	Base exterior de horno		1	1	-	-											
23	R682811	Base exterior de horno		-	-	1	1											
24	T072614	Soporte lateral aislante		1	-	-	-											
24	T112624	Soporte lateral aislante		-	1	-	-											
24	T122619	Soporte lateral aislante		-	-	1	1											
25	X260151	Pata regulable		4	4	4	4											
26	Q012042	Tornillo exagonal M-6x15		16	16	16	16											
27	Q242040	Arandela abanico A-6		16	16	16	16											
28	Q221343	Remache exagonal M-6		16	16	16	16											
29	R662682	Protector portamandos		1	-	-	-											
29	R672674	Protector portamandos		-	1	1	1											
30	Q412002	Remache tubular Ø 4x7,5		3	3	3	3											
31	R662616	Aislante posterior 560x60x20		3	3	4	4											
32	R662615	Aislante posterior 800x110x20		2	-	-	-											
32	R672631	Aislante posterior 670x230x20		-	2	2	2											
33	R662655	Soporte aislante posterior		1	-	-	-											
33	R672608	Soporte aislante posterior		-	1	-	-											

MOD.		HORNOS MIXTOS ELECTRONICOS		ZONA	MUEBLE INTERIOR								PLANO	C-1453			
ITEM	CODIGO	DENOMINACION	TEXTO	HME-6/11	HMP-6/11	HME-10/11	HMP-10/11	HME-10/21	HMP-10/21	HME-2-10/11	HMP-2-10/11						NOTAS
33	R682606	Soporte aislante posterior		-	-	1	1										
34	Q151301	Tornillo alomado		3	3	3	3										
35	R142628	Tejadillo motor turbina		1	1	1	1										
36	Q012042	Tornillo exagonal M-6x15		1	1	1	1										
37	Q221343	Remache exagonal M-6		1	1	1	1										
38	Q012042	Tornillo exagonal M-6x15		12	12	12	12										
39	Q262040	Arandela muelle A-6		12	12	12	12										
40	Q232040	Arandela plana A-6		12	12	12	12										
41	R662614	Aislante base y techo 650x650x20		5	5	-	-										
41	R682623	Aislante base y techo 860x790x20		-	-	5	5										
42	R662613	Aislante lateral 650x530x20		3	-	-	-										
42	R672630	Aislante lateral 770x650x20		-	3	-	-										
42	R682623	Aislante lateral 860x790x20		-	-	3	3										
43	R662613	Aislante lateral 650x530x20		2	-	-	-										
43	R672630	Aislante lateral 770x650x20		-	2	-	-										
43	R682623	Aislante lateral 860x790x20		-	-	2	2										
44	R662681	Cuerpo interior horno		1	-	-	-										
44	R672673	Cuerpo interior horno		-	1	-	-										
44	R682674	Cuerpo interior horno		-	-	1	1										
	R662636	Refuerzo base de cuerpo interior		1	1	-	-										
	R682633	Refuerzo base de cuerpo interior		-	-	1	1										
	R682663	Refuerzo vertical de cuerpo interior		-	-	2	2										
	Q232040	Arandela plana A-6		8	8	21	21										
	Q262040	Arandela muelle A-6		8	8	21	21										
	Q162040	Tuerca exagonal M-6		8	8	21	21										
45	Q222041	Remache exagonal M-4 inox.		24	28	28	28										
46	R662800	Cubre cables		1	1	1	1										
47	Q232030	Arandela plana A-5		2	2	2	2										
48	Q012031	Tornillo exagonal M-5x10		2	2	2	2										

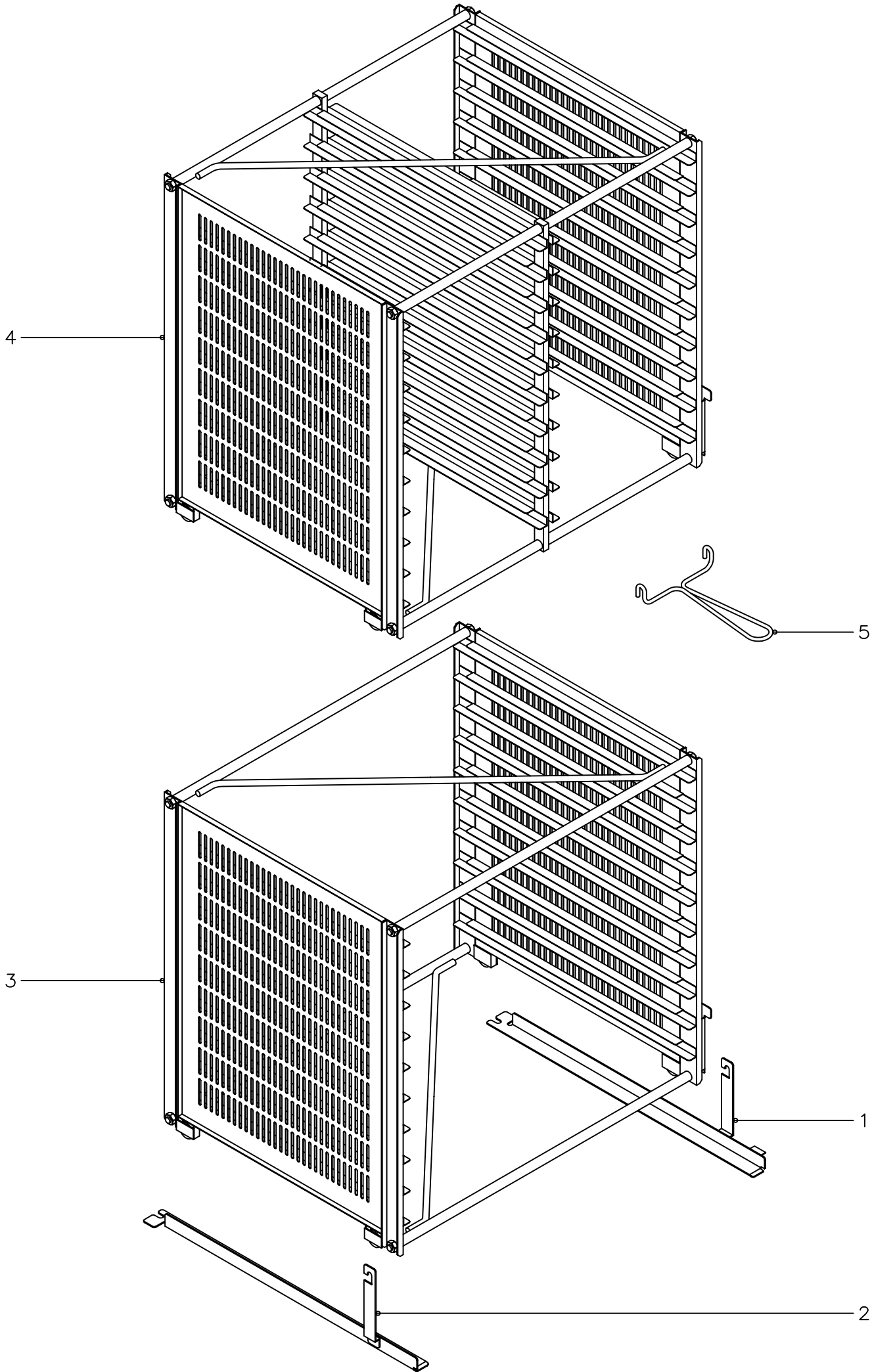

N plano C-1454	Firma 	Fecha 11-2003	Aparato EXTRUCTURAS PORTABANDEJAS HORNOS MIXTOS ELECTRONICOS	Lamina 4	Fagor Industrial S.Coop. FAGOR  Oñate
-------------------	----------------------------------------------------------------------------------------------	------------------	--------------------------------------------------------------------	-------------	--------------------------------------------------------------------------------------------------------------------------------------

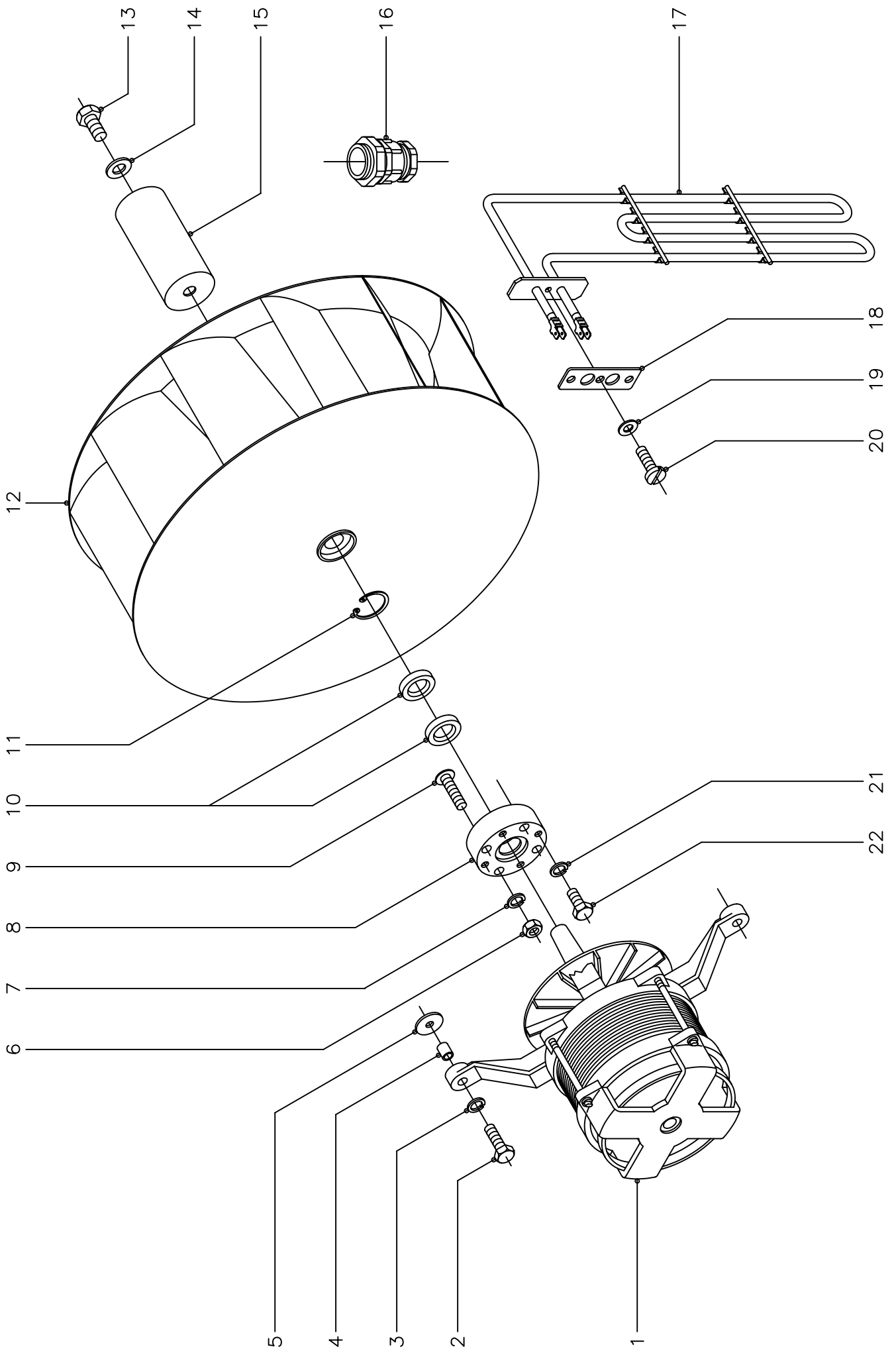

N plano C-1455	Firma 	Fecha 11-2003	Aparato TURBINA HORNOS MIXTOS ELECTRONICOS	Lamina 5	Fagor Industrial S.Coop. FAGOR Onate
-------------------	----------------------------------------------------------------------------------------------	------------------	--------------------------------------------------	-------------	------------------------------------------------

MOD.		HORNOS MIXTOS ELECTRONICOS		ZONA		TURBINA				PLANO		C-1455	
ITEM	CODIGO	DENOMINACION	TEXTO	HME-6/11	HMP-6/11	HME-10/11	HMP-10/11	HME-10/21	HMP-10/21	HME-2-10/11	HMP-2-10/11		NOTAS
1	R663033	Conj. motor (380/400 V., 50/60 Hz.)		1		1		1		1			
2	Q012044	Tornillo exagonal M-6x25		4		4		4		4			
3	Q262040	Arandela muelle A-6		4		4		4		4			
4	R663057	Casquillo amarre motor		4		4		4		4			
5	Q301304	Arandela calzo Ø 23xØ 6,5x2		8		8		8		8			
6	Q162040	Tuerca exagonal M-6		4		4		4		4			
7	Q262040	Arandela muelle A-6		4		4		4		4			
8	R662623	Casquillo reten		1		1		1		1			
9	-	Perno M-6 (Caldeado a cuerpo)		4		4		4		4			
10	R662627	Reten Ø 28xØ 17x7		2		2		2		2			
11	Q302023	Anillo de seguridad Ø 28x1,2		1		1		1		1			
12	R253042	Turbina		1		1		1		1			
13	Q012063	Tornillo exagonal M-10x20		1		1		1		1			
14	R763010	Arandela seguridad Hanning		1		1		1		1			
15	R665025	Distribuidor inyeccion		1		1		1		1			
16	R033002	Prensaestopas		1		1		1		1			
17	R663016	Resistencia 1500W., 230V.		6		-		-		-			
17	R673002	Resistencia 1500+1500W., 230V.		-		6		-		-			
17	R683000	Resistencia 2000+2000W., 230V.		-		-		6		6			
18	R693017	Junta resistencia 6/11		6		-		-		-			
18	R673063	Junta resistencia 10/11 y 10/21		-		6		6		6			
19	Q232030	Arandela plana A-5		6		18		18		18			
20	Q062031	Tornillo alomado M-5x10		6		18		18		18			
21	Q232030	Arandela muelle A-5		4		4		4		4			
22	Q012031	Tornillo exagonal M-5x10		4		4		4		4			

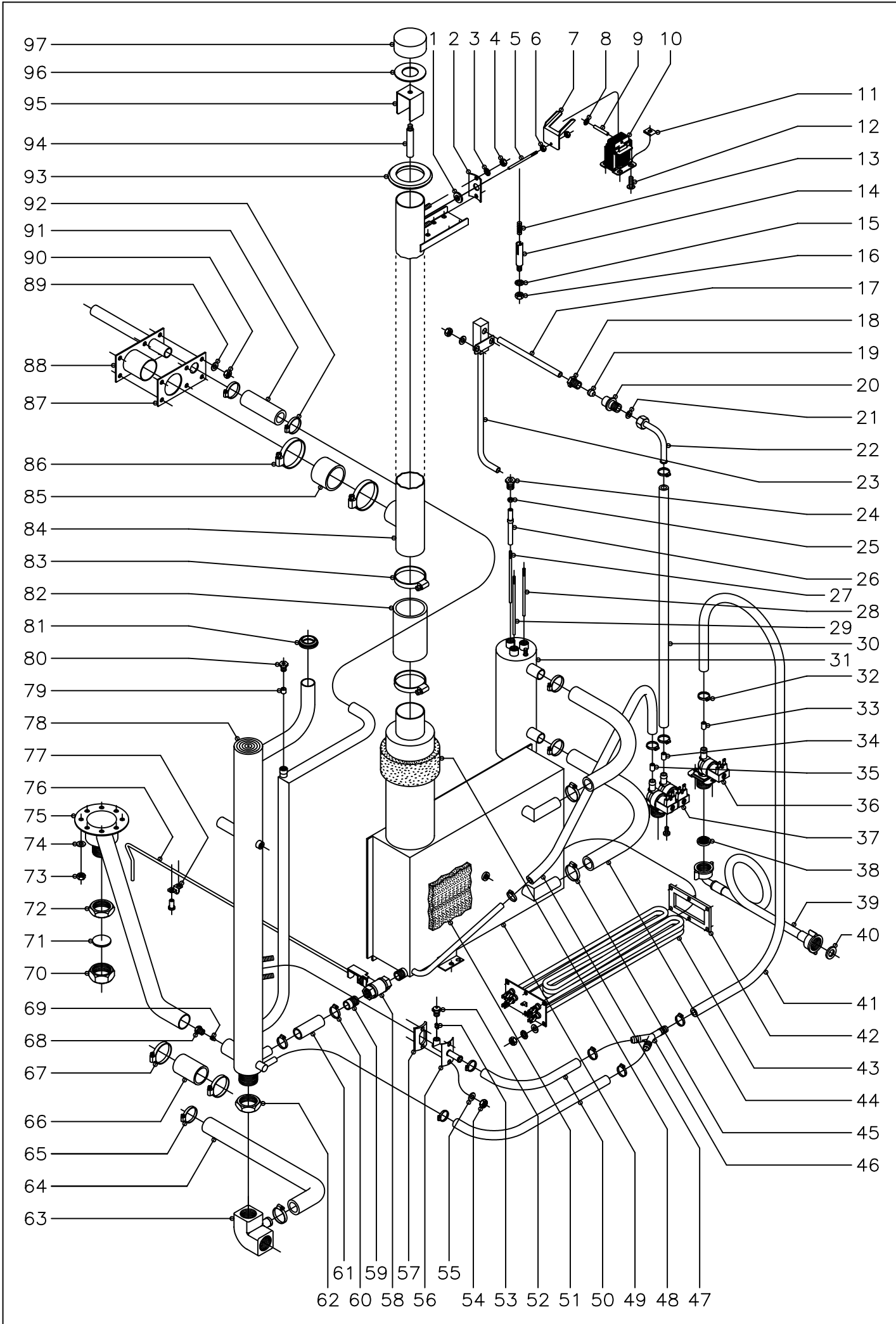

MOD.	HORNOS MIXTOS ELECTRONICOS	ZONA	CIRCUITO DE AGUA	PLANO	C-1456
------	-----------------------------------	------	-------------------------	-------	---------------

ITEM	CODIGO	DENOMINACION	TEXTO	HME-6/11	HMP-6/11	HME-10/11	HMP-10/11	HME-10/21	HMP-10/21	HME-2-10/11	HMP-2-10/11							NOTAS
1	R675033	Junta palanca accionamiento		1		1		1		1								
2	T115105	Amarre junta a conduccion vahos		1		1		1		1								
3	Q242030	Arandela abanico A-5		2		2		2		2								
4	Q162030	Tuerca exagonal M-5		2		2		2		2								
5	R675014	Palanca accionamiento		1		1		1		1								
6	Q162020	Tuerca exagonal M-4		2		2		2		2								
7	R672640	Escuadra accionamiento		1		1		1		1								
8	Q301035	Sujecion rapida Ø4		2		2		2		2								
9	R675016	Pasador electroiman		1		1		1		1								
10	R663030	Electroiman		1		1		1		1								
11	Q221012	Tuerca rapida M-5		2		2		2		2								
12	Q152004	Tornillo aplastado M-5x13		2		2		2		2								
13	Z883001	Resorte		1		1		1		1								
14	R665027	Guia resorte		1		1		1		1								
15	Q242040	Arandela abanico A-6		1		1		1		1								
16	Q162040	Tuerca exagonal M-6		1		1		1		1								
17	R665024	Tubo conduccion a inyector		1		1		1		1								
18	R695003	Manguito cierre		1		1		1		1								
19	R695004	Bicono		1		1		1		1								
20	-	Soldado a cuerpo de horno		1		1		1		1								
21	Q306025	Arandela junta Ø14xØ8,5x1,5		1		1		1		1								
22	R695017	Tubo conduccion agua		1		1		1		1								
23	R665020	Tubo inyector		1		-		-		-								
23	R675017	Tubo inyector		-		1		1		1								
	Q232030	Arandela plana A-5		2		2		2		2								
	Q162030	Tuerca exagonal M-5		2		2		2		2								
24	R345058	Racord amarre electrodos		3		3		3		3								
25	Q163020	Tuerca exagonal M-4		6		6		6		6								
26	R345059	Guia aislante de electrodos		3		3		3		3								

MOD.		HORNOS MIXTOS ELECTRONICOS		ZONA	CIRCUITO DE AGUA								PLANO	C-1456			
ITEM	CODIGO	DENOMINACION	TEXTO	HME-6/11	HMP-6/11	HME-10/11	HMP-10/11	HME-10/21	HMP-10/21	HME-2-10/11	HMP-2-10/11						NOTAS
27	R345063	Electrodo nivel bajo L=116		1		1		1		1							
28	R345060	Electrodo nivel alto L=106		1		1		1		1							
29	R345064	Electrodo de masa L=131		1		1		1		1							
30	3676900	Tubo de goma Ø17xØ10x1000		1		1		1		1							
31	R665046	Cuerpo de niveles		1		-		-		-							
31	R025011	Cuerpo de niveles		-		1		1		1							
32	Q881302	Abrazadera 12 - 20		6		6		6		6							
33	P443042	Regulador caudal (3 l./m.) negro		1		1		1		1							
34	R665041	Regulador caudal (0,25 l./m.) verde		1		1		1		1							
35	Z601156	Regulador caudal (8 l./m.) rojo		1		1		1		1							
36	Z701135	Electrovalvula simple		1		1		1		1							
37	P255001	Electrovalvula doble		1		1		1		1							
	Q032021	Tornillo alomado M-4x10		4		4		4		4							
38	Z701132	Filtro-junta entrada de agua		1		1		1		1							
39	Z601114	Manguera entrada de agua		2		2		2		2							
40	Q307031	Arandela junta Ø24xØ14x3		2		2		2		2							
41	3676900	Tubo de goma Ø17xØ10x900		1		1		1		1							
42	R145012	Junta cierre resistencias		1		2		2		2							
43	R143000	Resistencia (3000W.x3, 230 V.)		1		2		2		2							
	Q232030	Arandela plana A-5		6		12		12		12							
	Q242030	Arandela abanico A-5		6		12		12		12							
	Q162030	Tuerca exagonal M-5		6		12		12		12							
44	3715600	Tubo silicona forra. Ø26xØ18x400		2		2		2		2							
45	Q881305	Abrazadera 25 - 40		4		4		4		4							
46	Z201106	Racord en " Y "		1		1		1		1							
47	3676900	Tubo de goma Ø17xØ10x500		1		1		1		1							
48	R665052	Aislante salida generador		1		-		-		-							
48	R345013	Aislante salida generador		-		1		1		1							
49	R665042	Generador de vapor		1		-		-		-							

MOD.	HORNOS MIXTOS ELECTRONICOS	ZONA	CIRCUITO DE AGUA	PLANO	C-1456
------	-----------------------------------	------	-------------------------	-------	---------------

ITEM	CODIGO	DENOMINACION	TEXTO	HME-6/11	HMP-6/11	HME-10/11	HMP-10/11	HME-10/21	HMP-10/21	HME-2-10/11	HMP-2-10/11							NOTAS
49	R675024	Generador de vapor		-		1		1		1								
50	3676900	Tubo de goma Ø17xØ10x400		2		2		2		2								
51	R665051	Aislante cuerpo generador		1		-		-		-								
51	R345011	Aislante cuerpo generador		-		1		1		1								
52	Z651931	Tobera		1		1		1		1								
53	Z651932	Rodete		1		1		1		1								
54	Q162030	Tuerca exagonal M-5		2		2		2		2								
55	Q232030	Arandela plana A-5		2		2		2		2								
56	R015007	Conduccion vahos		1		1		1		1								
57	R345108	Junta conduccion vahos		1		1		1		1								
58	R015034	Cuerpo grifo vaciado		1		1		1		1								
59	R345014	Manguito grifo vaciado		1		1		1		1								
60	Q881304	Abrazadera 20 - 32		2		2		2		2								
61	3715600	Tubo silicona Ø26xØ18x120		1		1		1		1								
62	Q223014	Contratuerca 1"		1		1		1		1								
63	R665067	Codo desague		1		1		1		1								
64	3715600	Tubo silicona Ø26xØ18x1000		1		1		1		1								
65	Q881304	Abrazadera 20 - 32		2		2		2		2								
66	3714100	Tubo silicona Ø38xØ31x100		1		1		1		1								
67	Q881305	Abrazadera 25 - 40		2		2		2		2								
68	Z651931	Tobera		1		1		1		1								
69	Z651932	Rodete		1		1		1		1								
70	R665053	Tuerca tapon 1"		1		1		1		1								
71	R015011	Arandela junta tapon Ø34x3		1		1		1		1								
72	Q223014	Contratuerca 1"		1		1		1		1								
73	Q162040	Tuerca exagonal M-6		8		8		8		8								
74	Q232040	Arandela plana A-6		8		8		8		8								
75	R675022	Tubo de desague		1		1		-		-								
75	R685006	Tubo de desague		-		-		1		1								

MOD.		HORNOS MIXTOS ELECTRONICOS		ZONA	CIRCUITO DE AGUA								PLANO	C-1456			
ITEM	CODIGO	DENOMINACION	TEXTO	HME-6/11	HMP-6/11	HME-10/11	HMP-10/11	HME-10/21	HMP-10/21	HME-2-10/11	HMP-2-10/11						NOTAS
76	R342803	Palanca de grifo de vaciado		1		1		-		-							
76	R032804	Palanca de grifo de vaciado		-		-		1		1							
77	Q901306	Grapa amarre palanca grifo		1		1		1		1							
	Q412002	Remache tubular Ø 4x7,5		2		2		2		2							
78	R665048	Tubo retorno y chimenea		1		-		-		-							
78	R675030	Tubo retorno y chimenea		-		1		-		-							
78	R685010	Tubo retorno y chimenea		-		-		1		1							
79	3712400	Tubo-junta de silicona Ø8xØ3x20		1		1		1		1							
80	R662629	Racord cierre sonda		1		1		1		1							
81	N503017	Soporte termostato		1		1		1		1							Pasamuros chimenea
82	R345020	Tubo empalme generador		1		1		1		1							
83	Q881307	Abrazadera 40 - 60		2		2		2		2							
84	R675019	Conjunto chimenea		1		1		1		1							
85	3710900	Tubo silicona Ø51xØ43x40		1		1		1		1							
86	Q881307	Abrazadera 40 - 60		2		2		2		2							
87	R675038	Junta entrada y retorno		1		1		1		1							
88	R662658	Tubo entrada y retorno vapor		1		-		-		-							
88	R022613	Tubo entrada y retorno vapor		-		1		1		1							
89	Q232040	Arandela plana A-6		6		6		6		6							
90	Q162040	Tuerca exagonal M-6		6		6		6		6							
91	3715600	Tubo silicona forra. Ø26xØ18x100		1		1		1		1							
92	Q881304	Abrazadera 20 - 32		2		2		2		2							
93	R662813	Pasamuros chimenea		1		1		1		1							
94	R675008	Union retencion de vapores		1		1		1		1							
95	R675005	Guia retencion de vapores		1		1		1		1							
96	R675007	Junta retencion de vapores		1		1		1		1							
97	R675006	Retencion de vapores		1		1		1		1							

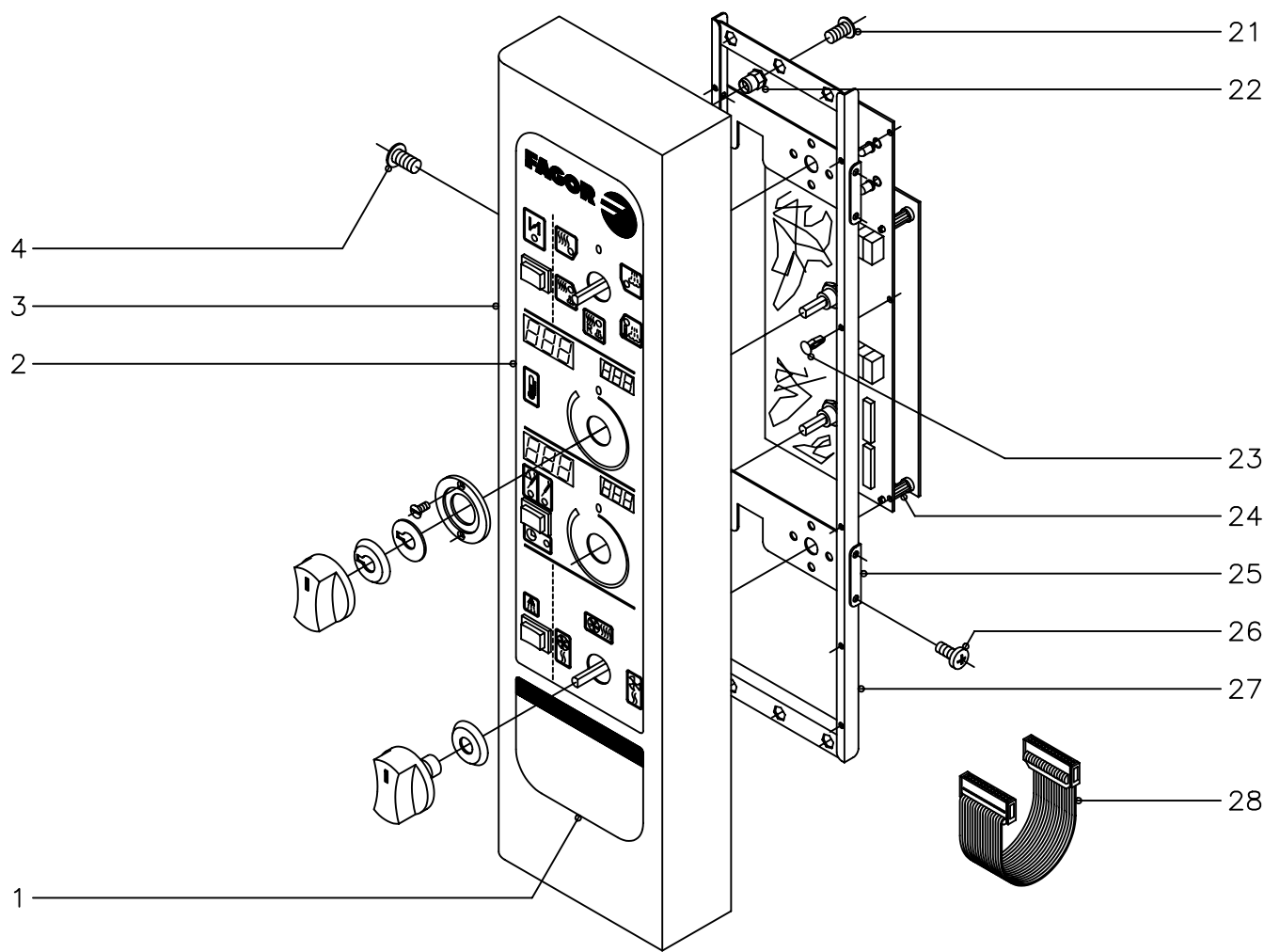
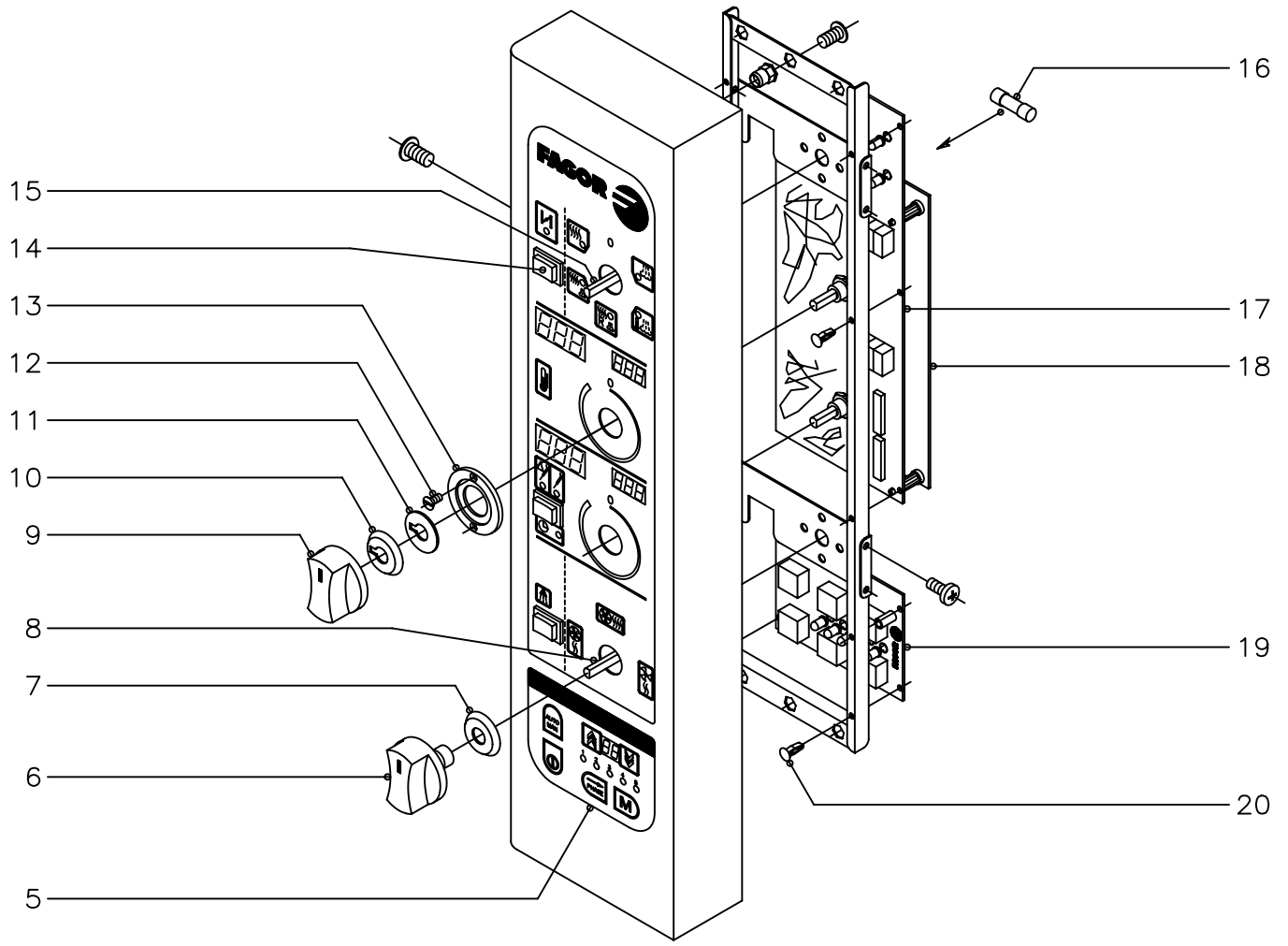

MOD.		HORNOS MIXTOS ELECTRONICOS		ZONA		SISTEMA ELECTRICO PORTAMANDOS						PLANO		C-1457	
ITEM	CODIGO	DENOMINACION	TEXTO	HME-6/11	HME-10/11	HME-10/21	HME-2-10/11	HMP-6/11	HMP-10/11	HMP-10/21	HMP-2-10/11				NOTAS
1	R663014	Serigrafia inferior (neutra)		1	1	1	-	-	-						
2	R663009	Serigrafia superior (controlador)		1	-	-	1	-	-						
2	R673000	Serigrafia superior (controlador)		-	1	1	-	1	1						
3	R662821	Panel portamandos 6/11		1	-	-	1	-	-						
3	R672818	Panel portamandos 10/11 y 10/21		-	1	1	-	1	1						
4	Q152004	Tornillo aplastado M-5x13		3	3	3	3	3	3						
5	R663010	Serigrafia inferior (programador)		-	-	-	1	1	1						
6	R663062	Boton de mando (conmutadores)		2	2	2	2	2	2						
7	R663046	Junta (conmutadores)		2	2	2	2	2	2						
8	R663026	Conmutador de funciones		1	1	1	1	1	1						
9	R663063	Boton de mando (electronica)		2	2	2	2	2	2						
10	R663045	Junta (circuito impreso)		2	2	2	2	2	2						
11	R662810	Arandela guia		2	2	2	2	2	2						
12	Q151346	Tornillo avellanado M-3x5		4	4	4	4	4	4						
13	R662809	Guia boton de mando		2	2	2	2	2	2						
14	R663032	Pulsador		3	3	3	3	3	3						
15	R663025	Conmutador de funciones		1	1	1	1	1	1						
16	R663101	Fusible 1 A.		1	1	1	1	1	1						
17	R663050	Circuito impreso mando		1	1	1	1	1	1						
18	R663085	Circuito impreso control		1	1	1	1	1	1						
19	R663004	Circuito impreso programador		-	-	-	1	1	1						
20	R663036	Remache fijacion circuito		-	-	-	4	4	4						
21	Q152004	Tornillo aplastado M-5x13		2	2	2	2	2	2						
22	Q221342	Remache exagonal M-5		2	2	2	2	2	2						
23	R663036	Remache fijacion circuito		6	6	6	6	6	6						
24	R663035	Separador		4	4	4	4	4	4						
25	R663008	Soporte conmutadores		2	2	2	2	2	2						
26	Q151320	Tornillo alomado M-4x6		8	8	8	8	8	8						
27	R663005	Soporte circuitos impresos		1	1	1	1	1	1						

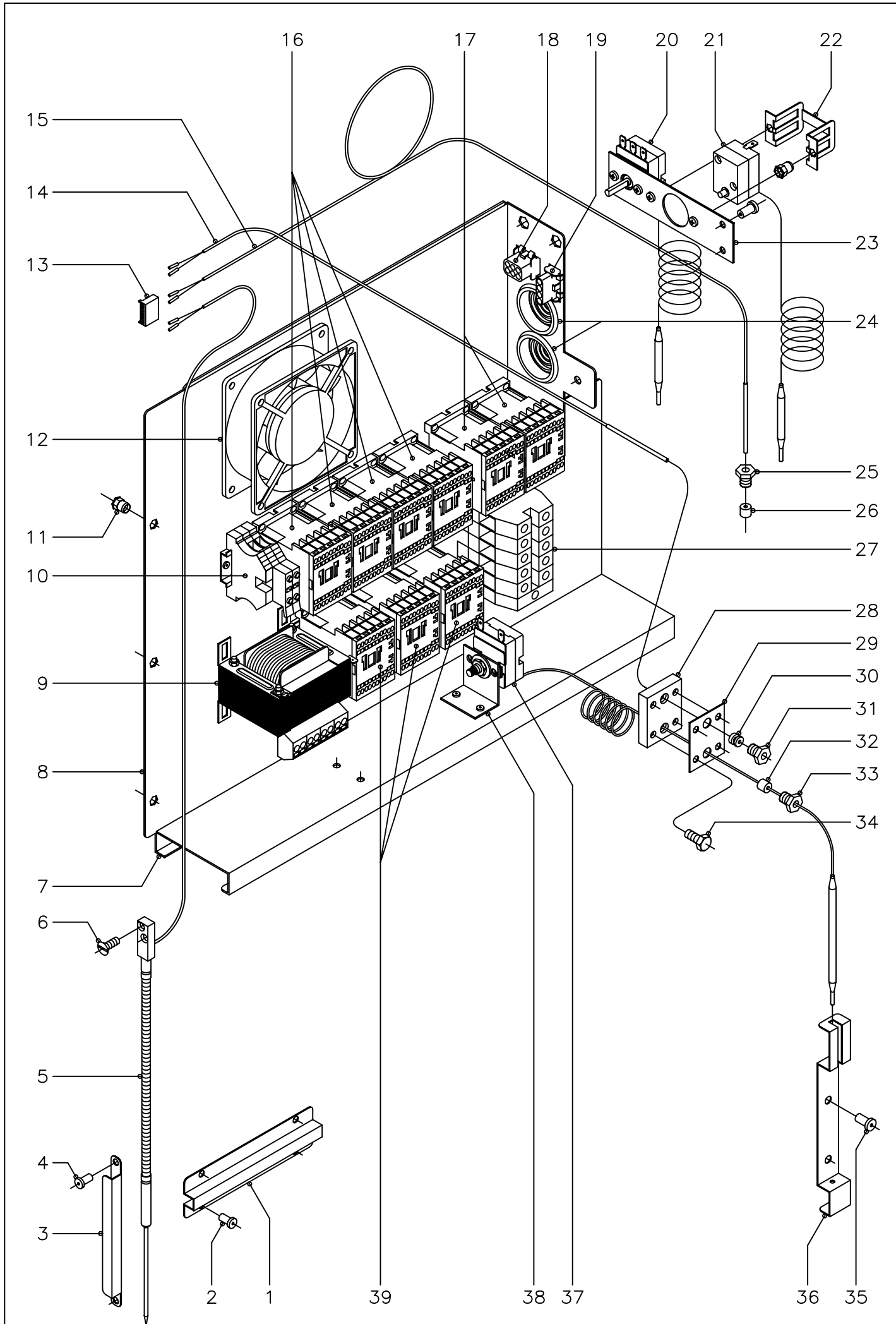

N plano C-1458	Firma 	Fecha 11-2003	Aparato CUADRO ELECTRICO HORNOS MIXTOS ELECTRONICOS	Lamina 8	Fagor Industrial S.Coop. FAGOR Onate
-------------------	-----------	------------------	-----------------------------------------------------------	-------------	------------------------------------------------

MOD.	HORNOS MIXTOS ELECTRONICOS	ZONA	CUADRO ELECTRICO	PLANO	C-1458
------	-----------------------------------	------	-------------------------	-------	---------------

ITEM	CODIGO	DENOMINACION	TEXTO	HME-6/11	HMP-6/11	HME-10/11	HMP-10/11	HME-10/21	HMP-10/21	HME-2-10/11	HMP-2-10/11							NOTAS
1	R662625	Soporte de sonda		1	-	-	-											
2	Q412002	Remache tubular Ø4x7,5		4	-	-	-											
3	R672643	Soporte de sonda		-	1	1	1											
4	Q412002	Remache tubular Ø4x7,5		-	2	2	2											
5	R663091	Conjunto sonda nucleo		1	-	-	-											
5	R673059	Conjunto sonda nucleo		-	1	1	1											
6	Q042022	Tornillo avellanado M-4x15		2	2	2	2											
7	R663018	Contra guia panel cuadro		1	1	1	1											
	Q412002	Remache tubular Ø4x7,5		7	7	7	7											
8	R663081	Panel cuadro electrico		1	1	1	1											
9	R503005	Transformador		1	1	1	1											
10	R073005	Bornas portafusibles		2	2	2	2											
	P184011	Cartucho fusible 4 A.		2	2	2	2											
	Z263303	Tope final		1	1	1	1											
11	Q221342	Remache exagonal M-5		3	3	3	3											
12	Z103066	Ventilador		1	1	1	1											
13	R663093	Conector 6 vias		1	1	1	1											
14	R663090	Conjunto termopar L=1500		1	1	1	1											
15	R663089	Conjunto termopar L=2500		1	1	1	1											
16	Z203050	Contactador sirius 3RT-1016-2AP01		2	4	4	4											
	R693009	Guia contactor L=250		1	1	1	1											
17	Z203050	Contactador sirius 3RT-1016-2AP01		2	2	2	2											
	Z403016	Guia contactor L=100		1	1	1	1											
18	-	Conector hembra 6vias		1	1	1	1											
19	-	Conector hembra 4vias		1	1	1	1											
20	R343100	Termostato de condensacion		1	1	1	1											
	Q153111	Tornillo alomado M-4x8		2	2	2	2											
21	Z213014	Termostato Tecasa de seguridad		1	1	1	1											
22	Z203060	Amarre limitador Tecasa		1	1	1	1											

MOD.	HORNOS MIXTOS ELECTRONICOS	ZONA	CUADRO ELECTRICO	PLANO	C-1458
------	-----------------------------------	------	-------------------------	-------	---------------

ITEM	CODIGO	DENOMINACION	TEXTO	HME-6/11	HMP-6/11	HME-10/11	HMP-10/11	HME-10/21	HMP-10/21	HME-2-10/11	HMP-2-10/11							NOTAS
	Q221341	Remache exagonal M-4		2		2		2		2								
	Q153111	Tornillo alomado M-4x8		2		2		2		2								
23	R673061	Soporte amarre termostatos		1		1		1		1								
	Q412002	Remache tubular Ø4x7,5		2		2		2		2								
24	N103013	Pasacables		2		2		2		2								
25	R662629	Racord cierre sonda		1		1		1		1								
26	3712400	Tube-junta de silicona Ø8xØ3x20		1		1		1		1								
27	P453025	Borne gris fases 10		3		-		-		-								
	R263003	Borne gris fases 35		-		3		3		3								
	Z263302	Borne azul neutro 10		1		-		-		-								
	R673010	Borne azul neutro 35		-		1		1		1								
	P453026	Borne verde-amarillo tierra 10		1		-		-		-								
	Z103035	Borne verde-amarillo tierra 35		-		1		1		1								
	Z263303	Tope final		1		-		-		-								
	Z683096	Tope final 35		-		1		1		1								
	R663055	Guia contactor 120		1		1		1		1								
28	R662659	Pasamuros doble para sonda		1		1		1		1								
29	R692811	Junta pasamuros doble		1		1		1		1								
30	R662652	Bicono cierre sonda		1		1		1		1								
31	R662629	Racord cierre sonda		1		1		1		1								
32	R662662	Junta cierre bulbo limitador		1		1		1		1								
33	R662629	Racord cierre sonda		1		1		1		1								
34	Q012021	Tornillo exagonal M-4x10		4		4		4		4								
35	Q412002	Remache tubular Ø4x7,5		2		2		2		2								
36	R662630	Soporte de bulbo		1		1		1		1								
37	R243016	Termostato limitador temperatura		1		1		1		1								
38	R343039	Soporte de termostatos		2		2		2		2								
39	Z203050	Contactor sirius 3RT-1016-2AP01		1		3		3		3								
	Z103084	Guia contactor 138		1		1		1		1								

3N-50/60Hz
380/415V

MODELO HME-10/11 HMP-10/11

HME-10/21 HMP-10/21

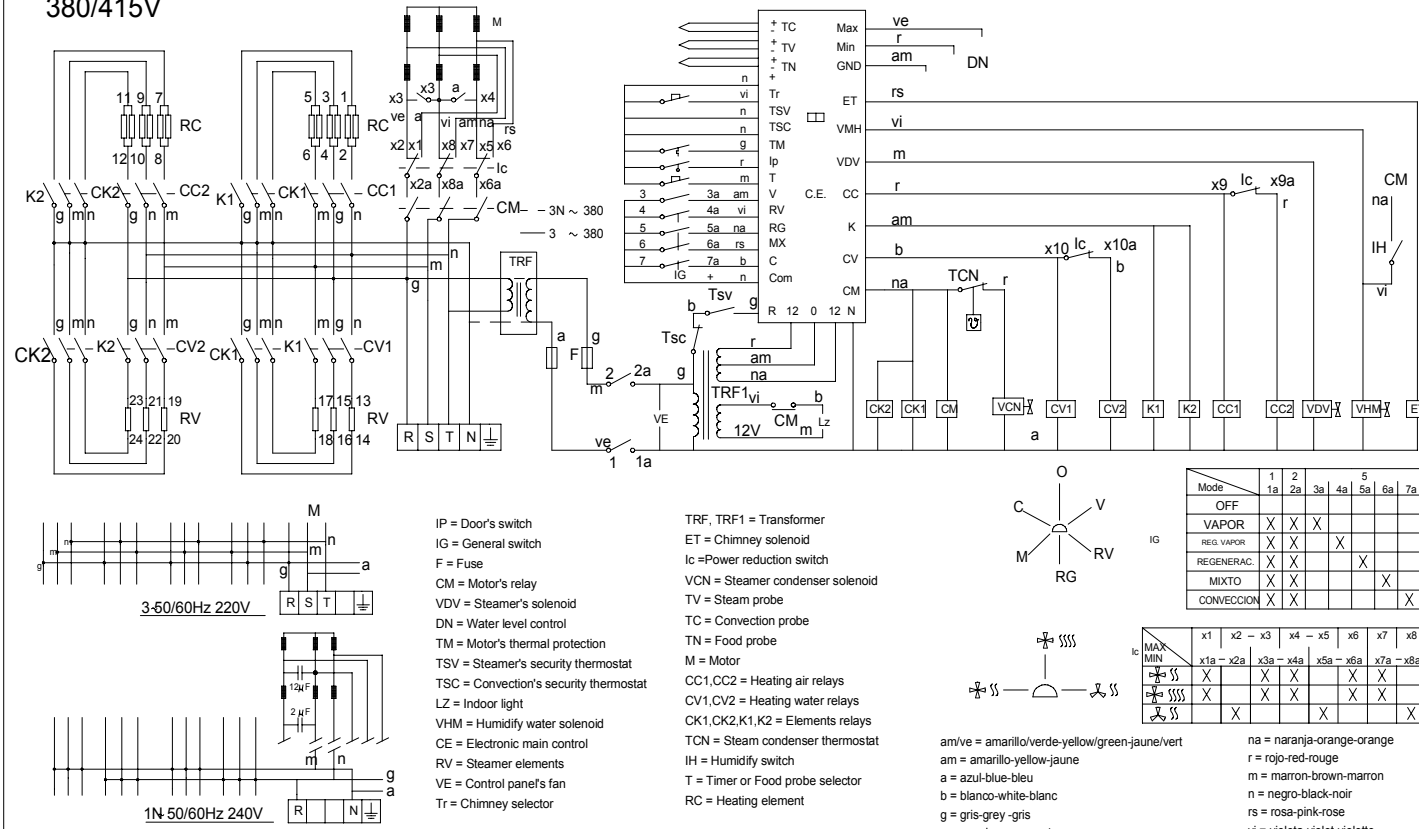

R-673058

HC-74198

		3~50/60Hz 220V			
ESQUEMA TEORICO ADHESIVO		3N-50/60Hz 380/415V		R-673058	
Nº	Pieza	Cant.	Material	Nº Clasificacion	Acabado
Nº	Modificacion	Propuesta de		Fecha	Tolerancias generales
					<5±
					5-25±
					25-50±
					50-100±
					>100±
					<±
Dibujado	Firma	Fecha			Mecanizado superficial
Proyectado	Iratxe	17/3/99			
Comprobado			Fagor Industrial, Koop, Elk, Mugatua		Plano numero HC-74198
Escala			<p style="text-align: center;">HORNO MIXTO HME HMP</p>		
Plano hau ez daiteke erabili ez bezitza gure baimenitaz gabe					Sustituye al N° hc-73221
					Sustituido por

