DESPIECES DEL SERVICIO TECNICO

COCCION

Hornillo de Pavimento

HP/G-15

ENERO, 1999



Fagor Industrial, S. Coop.

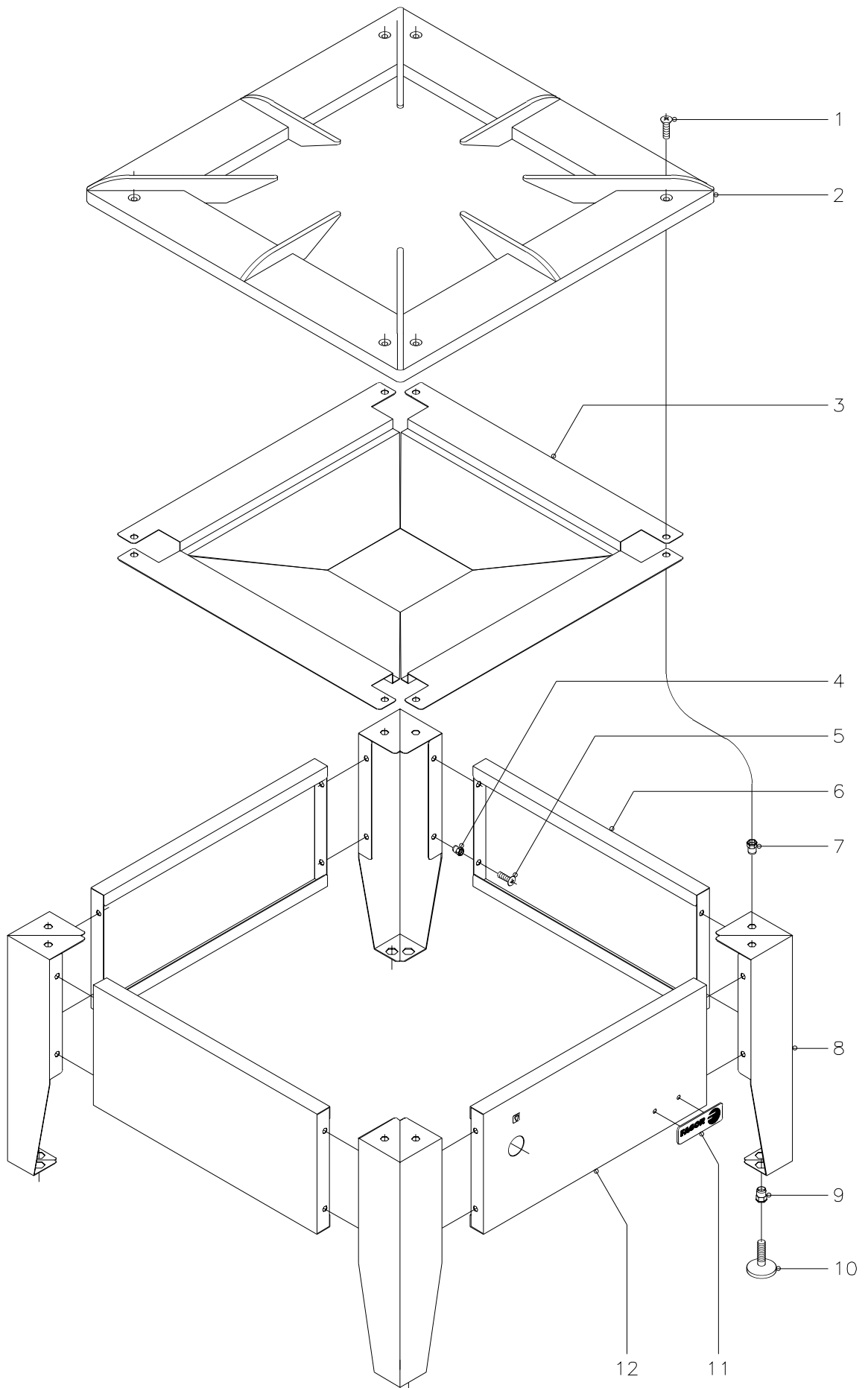

| | | | | | | |
|------------------|-----------------------------|---------------|-----------------------------|-------------|-----------------------------------|----------------------------------------------------------------------------------------------------|
| N plano C-661 | Firma <i>[Signature]</i> | Fecha 1-99 | Aparato HORNILLO HP/G-15 | Lamina 1 | Fagor Industrial S.Coop. D<ate | FAGOR  |
|------------------|-----------------------------|---------------|-----------------------------|-------------|-----------------------------------|----------------------------------------------------------------------------------------------------|

